

Solar Hydrogen Extension

Instruction Manual



Solar Hydrogen Extension, Instruction Manual
Version 2.3
April 2026

© **Heliocentris Academia International GmbH**
Rudower Chaussee 30
12489 Berlin
Germany

All rights reserved. No part of this Instruction Manual may be reproduced, stored in a data retrieval system or transmitted by any means without the prior written permission of the issuer. The following exception applies: photocopying pages from the manual for instruction for or by lecturers is allowed.

Components of the Solar Hydrogen Extension are protected by patents and / or utility patents. Solar Hydrogen Extension is a trademark of Heliocentris Academia International GmbH, Germany. Windows is a registered trademark of Microsoft Corporation in the USA and other countries. We reserve the right to make changes.

Contents

| | | |
|----------|--|-----------|
| 1 | About This Document..... | 5 |
| 1.1 | Notices and Symbols | 5 |
| 1.1.1 | Symbols | 5 |
| 1.1.2 | Warnings | 6 |
| 1.1.3 | Tips | 6 |
| 1.2 | Accompanying Documents | 6 |
| 2 | Safety Instructions | 7 |
| 2.1 | General Information on Safety & Responsibility | 7 |
| 2.2 | Approved Use | 7 |
| 2.3 | Non-Approved Use..... | 8 |
| 2.4 | Hazards during Approved Use | 8 |
| 2.5 | General Information on Operation | 9 |
| 2.5.1 | Requirements for the Owner/Operator..... | 9 |
| 2.5.2 | Requirements for the Location / Installation Location | 9 |
| 2.5.3 | Requirements for the User | 10 |
| 3 | Components..... | 11 |
| 3.1 | Power Management Cabinet | 11 |
| 3.1.1 | System Control..... | 13 |
| 3.2 | Solar Battery | 13 |
| 3.3 | Solar Modules..... | 14 |
| 3.4 | Power Management Monitor Software | 14 |
| 3.4.1 | Views and Navigation | 15 |
| 3.4.2 | Electrolyzer Control Area | 16 |
| 3.4.3 | Data Acquisition Control Area | 17 |
| 3.4.4 | Errors / Warnings | 17 |
| 3.4.5 | Menu..... | 17 |
| 3.5 | Optional Component | 18 |
| 3.5.1 | Hydrogen Generator | 18 |
| 3.5.2 | PV Sensor Kit | 18 |
| 3.5.3 | Metal Hydride Canister | 18 |
| 4 | Getting Started | 19 |
| 4.1 | Scope of Delivery | 19 |
| 4.2 | Installation Location..... | 20 |
| 4.3 | Unpacking, Installation and Connection..... | 21 |
| 4.3.1 | Unpacking and Installation | 21 |
| 4.3.2 | How to Install Solar Batteries | 22 |
| 4.3.3 | How to Connect PC and Hydrogen Generator..... | 24 |
| 4.3.4 | How to Ground the Hydrogen Extension | 24 |
| 4.3.5 | How to Install, Align and Connect the Solar Module..... | 24 |
| 4.3.6 | How to Connect the PV Sensor Kit (Optional)..... | 27 |
| 4.4 | How to Install the Power Management Monitor Software on the PC | 27 |

| | | |
|----------|---|-----------|
| 4.4.1 | How to Install the Power Management Monitor Software | 27 |
| 4.4.2 | How to Establish Communication between the PC and Solar Hydrogen Extension..... | 28 |
| 5 | Operation | 29 |
| 5.1 | How to Operate the SHE Autonomously..... | 29 |
| 5.2 | How to Operate the SHE with Power Management Monitor Software..... | 30 |
| 5.2.1 | Off function..... | 30 |
| 5.2.2 | SHE Automatic Function..... | 30 |
| 5.2.3 | PC Automatic Function | 31 |
| 5.2.4 | PC Manual Mode..... | 31 |
| 5.2.5 | How to Change Software Settings..... | 32 |
| 5.2.6 | How to Record Data | 33 |
| 5.2.7 | How to Calibrate Sensors | 34 |
| 5.2.8 | How to End Software | 35 |
| 5.3 | Overview Tab | 35 |
| 5.4 | Degree of Efficiency Tab..... | 36 |
| 5.5 | Diagram Tab | 37 |
| 6 | Decommissioning | 41 |
| 6.1 | How to Shut Down the System..... | 41 |
| 6.2 | How to Store the System..... | 42 |
| 6.3 | How to Ship the System | 43 |
| 6.4 | How to Uninstall the Software | 43 |
| 7 | Maintenance and Service | 45 |
| 7.1 | Serial Number & Service | 45 |
| 7.2 | Maintenance..... | 45 |
| 7.3 | Cleaning | 46 |
| 7.4 | Service | 46 |
| 7.5 | Disposal..... | 47 |
| 7.6 | Warranty | 47 |
| 8 | Technical Data..... | 49 |
| 8.1 | Complete System..... | 49 |
| 8.2 | Power Management Cabinet | 49 |
| 8.3 | Batteries | 49 |
| 8.4 | Solar Module..... | 50 |
| 8.5 | PC requirements..... | 50 |
| 8.6 | Hydrogen generator HG 30..... | 51 |
| 8.7 | Hydrogen generator HG 72..... | 51 |
| 9 | Appendix | 53 |

1 About This Document

The instruction manual is intended to help you use the product and to prepare for experiments. These experiments are described in detail in the included Teacher's Guide. The instruction manual is structured as follows.

| | |
|-------------------------|---|
| Safety Instructions | In the safety chapter you will find information on the safe handling of the product. It is essential that you read and understand this chapter. |
| Components | This chapter presents the components and basic functions of the product. |
| Getting Started | This chapter describes the scope of delivery and the necessary steps for initial startup of the product – from the selection of a suitable installation location to the connection of all necessary components. It is supplemented by the laminated setup instructions. |
| Operation | The chapter provides instruction for the operation of the product. |
| Decommissioning | The necessary steps for the disassembly product and the conditions for its packaging, storage and transport are described in the chapter. |
| Maintenance and Service | This chapter describes all necessary measures arising in the product life cycle, such as the maintenance, cleaning, service, warranty and disposal. |
| Technical Data | An overview of important technical data is provided at the end of the operating manual. |
| Appendix, Index | The parameters, symbols and abbreviations used in this manual are summarized in the appendix for a better overview and an index can be used for fast orientation. |

1.1 Notices and Symbols

1.1.1 Symbols

The following symbols and labels are used in this manual:

| Symbol or label | Meaning |
|-------------------------------------|--|
| ▶ | Instruction |
| ✓ | Aids or prerequisites that are required prior to an action |
| 1. | Instructions in a specific sequence |
| ⇒ | Result of an action |
| • | List |
| <i>Switch</i> | Refers to a switch, key, button or icon |
| Reference to page x | Reference to further information |

Table 1-1

1.1.2 Warnings

The following warnings are used:



DANGER

Warns of dangers of death.



WARNING

Warns of dangers of serious injury.



CAUTION

Warns of dangers of injury.



NOTICE

Warns of property damage to the product.

1.1.3 Tips

Useful tips are identified as follows:



TIP

Provides further tips.

1.2 Accompanying Documents

The following documents are supplied with the product in addition to the instruction manual:

- Experiment guide
- USB-Stick with the instruction manuals and the Power Management Monitor Software
 - *Hydrogen Generator HG 72 / HG 30 Instruction Manual*
 - *Metal Hydride Canister Instruction Manual and Insert Metal Hydrogen Canister*
 - *Battery Instruction Manual*

2 Safety Instructions

In this chapter you will find information on the safe handling of the product. It is essential that you read and understand this chapter.

2.1 General Information on Safety & Responsibility

Danger of injury due to improper use!

Improper use of the product can result in serious injuries.



- ▶ Ensure that the manual is accessible at all times.
- ▶ Make sure you have read and understood this manual in its entirety.
- ▶ Comply with all safety instructions and warnings.
- ▶ Store the manual and other documentation in a safe place and pass them on to future owners of the product.
- ▶ Comply with all local regulations.
- ▶ Use only product components. Exception: if other aids are specified in the manual.

Danger of death due to unauthorized modifications!

Conversions and modifications to the product can result in general hazards (danger of injury due to escaping hydrogen, danger of injury due to heavy parts, danger of death due to electric shock).

Alterations and a modification to the product void the warranty.

- ▶ Do not make conversions and modifications to the product or its individual components.
- ▶ Do not remove components.

2.2 Approved Use

The product has been designed for:

- Analysis and test purposes
- Experimentation purposes
- Demonstration purposes
- Training purposes
- Research purposes

The product is not intended for any other purpose; any other use is not approved.

The product must always be operated while under supervision.

The use of the hydrogen supply, which is available as an accessory, is subject to special safety regulations and is intended only in combination with the product for the purposes listed above.

2.3 Non-Approved Use

Do **not** use this product for:

- Use with components not mentioned in this document
- Generation of electricity and heat for other purposes than those stated above
- Operation beyond the technical specifications
- Operation beyond the approved operating environment
- Feeding generated energy into the mains grid
- Unsupervised operation
- Operation in potentially explosive areas

Components or products delivered by or purchased from Heliocentris are not approved for use in aeronautics or aerospace applications (including models).

2.4 Hazards during Approved Use

- Electricity The unit poses no special electrical hazards as long as the following instructions are observed:
- ▶ Use only the supply voltage specified on the rating plate.
 - ▶ Do not feed current into the mains grid.
 - ▶ Do not short-circuit inputs and outputs.
 - ▶ Do not reverse the polarity of inputs and outputs.
 - ▶ Do not insert any mechanical parts, especially metal parts, into the product through the ventilation slots.
 - ▶ Do not use liquids near the product.
 - ▶ Never use the product if any part of it has been immersed in water!
 - ▶ Operate only when the doors of SHE are closed!
- Hydrogen When using the hydrogen generator threatens danger of death due to explosion!
- Hydrogen itself is not a hazardous substance – its properties, however, can make it hazardous in interaction with other substances.
- Escaping hydrogen can ignite and burn the skin.
- Escaping hydrogen can reduce the oxygen concentration and cause respiratory difficulties.
- ▶ Do not inhale hydrogen.
 - ▶ The lab must be equipped with a suitable ventilation system for the use of hydrogen.
 - ▶ Integrate the device into the operational safety concept.
 - ▶ The lab must be equipped for hydrogen monitoring.
 - ▶ Avoid heat in the vicinity of the system and the hydrogen source.
 - ▶ No smoking, no naked flames.
 - ▶ Comply with local safety regulations.
 - ▶ Comply with regulations for handling of compressed hydrogen cylinders.

- ▶ In the case of escaping gas, keep away and keep inflammable materials away.
- ▶ Prevent electrostatic charges.
- ▶ Ensure proper installation of the hydrogen supply.
- ▶ Check the hydrogen lines and connectors regularly for leak tightness.

2.5 General Information on Operation

2.5.1 Requirements for the Owner/Operator

The owner/operator must ensure that the unit is accessible only to the persons defined in this manual (see [Requirements for the User](#) page 10).

The safety instructions and warnings listed in this instruction manual must be observed. The owner /operator is responsible for compliance with local safety regulations.

Furthermore, the owner / operator is responsible for the implementation of a risk analysis in accordance to national law and regulations concerning occupational health and safety.

Hydrogen Furthermore, when using the hydrogen generator the owner /operator is responsible for:

- Creation of an EX-protection document
- Proper installation of the hydrogen supply by a specialized company
- Regular checking of the hydrogen lines and connectors for leak tightness
- Unauthorized persons must be prevented, using corresponding measures, from installing, operating or maintaining the system. Installation, commissioning, shutdown and maintenance of the hydrogen supply and filling the metal hydride canisters must be carried out by appropriately qualified personnel.
- Replacement and cleaning of filters if used under dirty operating conditions and/or impaired ventilation

The owner /operator of the system must take sufficient precautions to prevent hydrogen being able to accumulate in enclosed or non-ventilated areas (e.g. installation of an exhaust air system and hydrogen warning system, etc.).

2.5.2 Requirements for the Location / Installation Location

The system must be operated in a lab that complies with local regulations (refer to Guidelines for Laboratories BGI 850-0e Working Safely in Laboratories – Basic Principles for Laboratories).

Hydrogen When using the hydrogen generator the lab must be equipped for hydrogen monitoring. The following extinguishing agents must also be present:

Hydrogen belongs to fire class C. It requires an ABC-extinguisher.

Metal hydride canister Metal hydride belongs to fire class D. It requires a D-extinguisher. Never use a CO₂-extinguisher or water!

2.5.3 Requirements for the User

The product is intended as a laboratory system for use by trained qualified personnel in education and research. Its design does not correspond to that of a "consumer-oriented" product whose proper use is generally known and which is protected against operation errors or improper use. The product may be used by the following persons under the following conditions:

- | | |
|---|--|
| Qualification | <ul style="list-style-type: none">• Persons who can demonstrate proof of training in chemistry, physics, electronics, electrical engineering or comparable qualifications and who are familiar with the local regulations for safe handling of hydrogen and who have experience in working with hydrogen.• Personnel must be familiar with and comply with the local applicable accident prevention and safety regulations. |
| There is an obligation of supervision during all training | <ul style="list-style-type: none">• The solar-hydrogen system may be used by persons undergoing training only when under the supervision of the instructor.• The instructor must ensure proper handling and is obliged to point out possible dangers. |

3 Components

The Solar Hydrogen Extension (hereinafter referred to as SHE) is a modular training system for the generation of hydrogen from regenerative energies.



Figure 3-1 SHE

1 Solar module

3 Power Management Cabinet

2 Hydrogen generator

It is comprised of 2 solar modules, Power Management Cabinet and management software. The software features visualization, recording of measurements and partial parameterization of the system.

Metal hydride canisters, a hydrogen generator and PV sensor kit are optionally available (see [Optional Components](#) on page 18). In addition, the SHE can be combined with a variety of Heliocentris fuel cell systems.

3.1 Power Management Cabinet

The Power Management Cabinet is the basis of the SHE. This cabinet contains all necessary components for the control and monitoring of the solar modules, solar batteries and the hydrogen generator:

- System Control
- Inverter
- DC/DC Converter
- Solar load regulator

The front door is partially made of an acrylic glass pane.



Figure 3-2 Components of the front side of the cabinet

- | | |
|---|------------------------|
| 1 DC/DC Converter | 2 Solar load regulator |
| 3 Automatic circuit breakers, current sensors and terminals | 4 Inverter |
| 5 System Control | |

The user interface with all necessary connections and the main battery switch are located on the side of the cabinet.



Figure 3-3 User interface on the side of the cabinet

- | | |
|--|--|
| 1 Main battery switch <i>Off</i> position | 2 DC input from the solar modules |
| 3 LAN connection to PC | 4 Communication connection to the hydrogen generator |
| 5 Communication connection to the optional PV sensor kit | 6 AC output |
| 7 DC output | |

The solar batteries are installed and connected in the rear section of the cabinet.

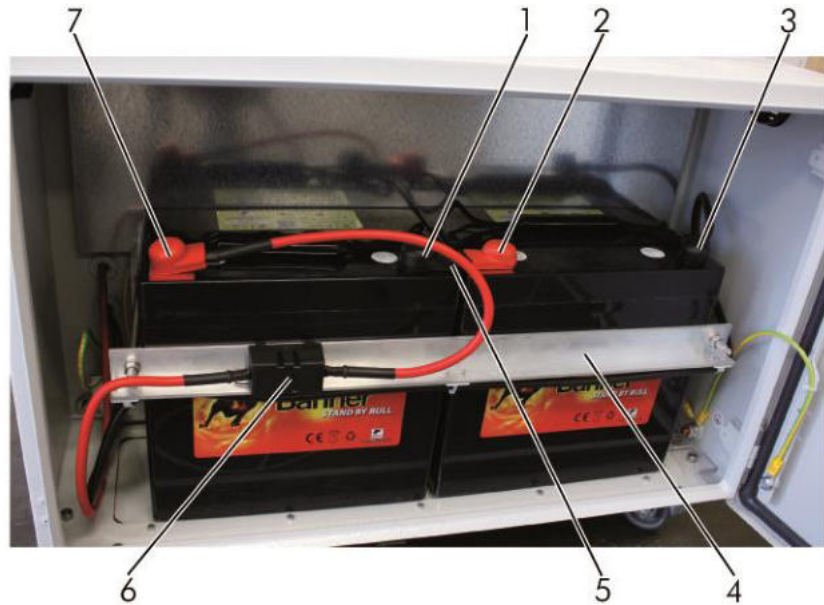

Figure 3-4 Solar batteries

- | | |
|-----------------|-------------------|
| 1 Negative pole | 2 Positive pole |
| 3 Negative pole | 4 Supporting rail |
| 5 Jumper | 6 Fuse |
| 7 Positive pole | |

3.1.1 System Control

A programmable logic controller (PLC) is used for the system control and monitoring.

3.2 Solar Battery

55Ah/12V *fleece batteries* are closed, valve-regulated lead batteries with electrolyte located in the fleece. These block batteries are characterized by a universally applicable and entirely maintenance-free design.



Exemplary illustration

3.3 Solar Modules

Solar energy is converted into electrical energy by the solar modules. The solar modules are located on rolling racks with an adjustable angle so that they can be positioned facing various directions. A solar module is equipped with a compass in order to enable correct alignment with geographic coordinates. Each of the solar modules delivers > 250 W.



Figure 3-6 Solar module (only one pictured)

3.4 Power Management Monitor Software

Voltage, current and resulting values can be monitored and recorded with the Power Management Monitor software. The lower and upper battery voltage limit can also be set. The lower battery voltage limit protects against total discharge during operation.

In order to illustrate the functionality of the system, the following data is recorded and represented in a graph. The data set depends on the connected components:

- Voltage and current of the solar modules
- Voltage, charge and discharge current of the batteries
- Rated voltage of the 12 V DC output
- Rated power, voltage and current of the 230 V AC output
- Solar irradiation
- Outdoor temperature
- Module temperature (measured on rear side of solar modules)
- Hydrogen production
- Water quality
- System current
- Input current AC converter

3.4.1 Views and Navigation

Elements of the window

The window contains a view (1), the control area (2), the menu (3) and the navigation bar (4).

The navigation bar (4) is positioned above the view (1). Each view can be activated by clicking on the corresponding tab.

The control area contains buttons for the control of the system and/or individual modules and functions, their status displays and a display field for error messages.

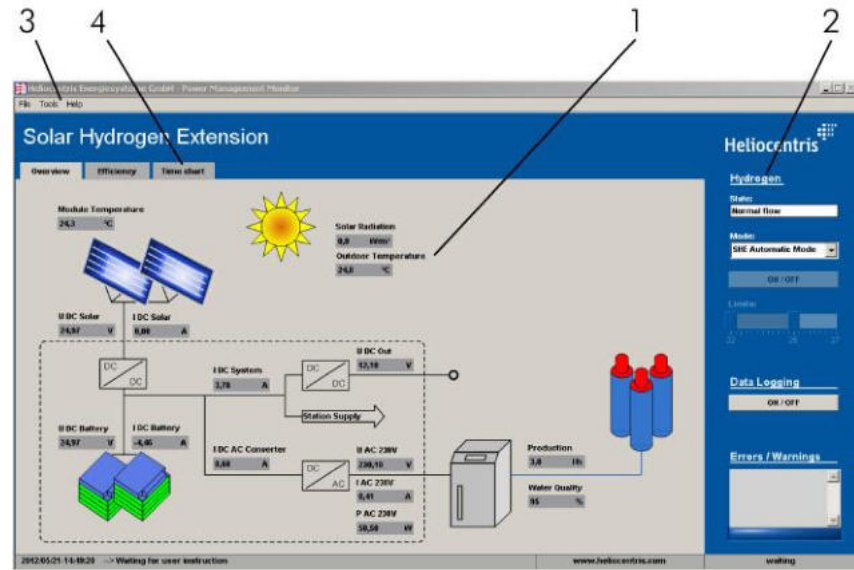

Figure 3-7 Overview tab

- 1 View
- 2 Control area
- 3 Menu
- 4 Navigation bar

The Power Management software includes the following views:

Overview tab

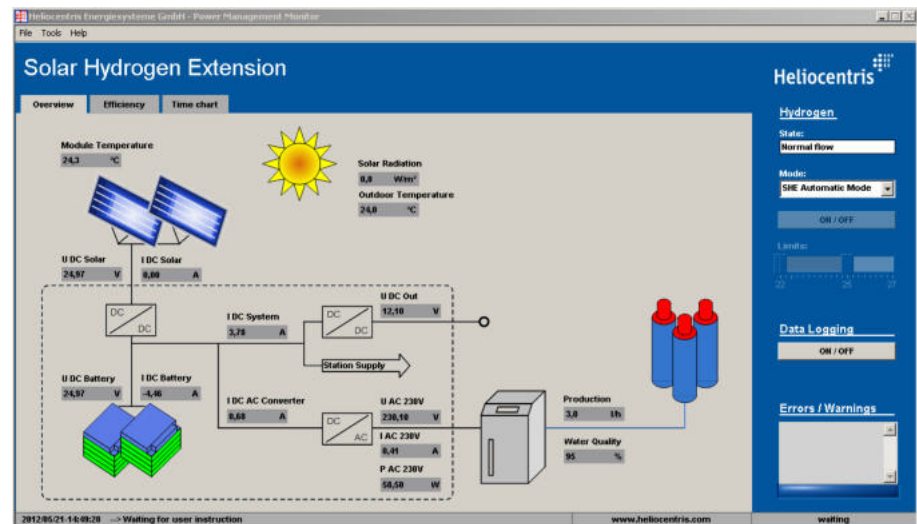

Figure 3-8: Overview of the system components (with optional PV sensor kit connected)

– See [Overview Tab](#) on page 35

Efficiency tab

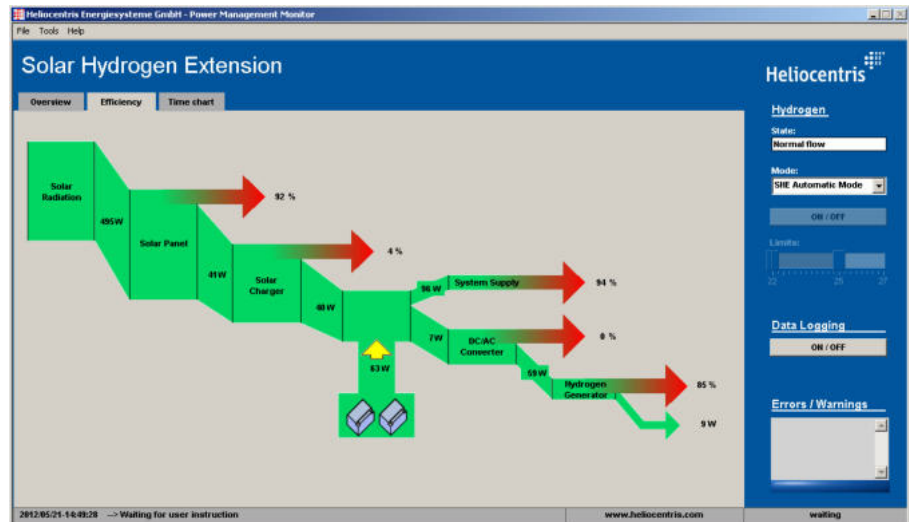

Figure 3-9: Power, energy conversion stages and the resulting degree of efficiency, respectively.

– See [Degree of Efficiency Tab](#) on page 36

Diagram tab

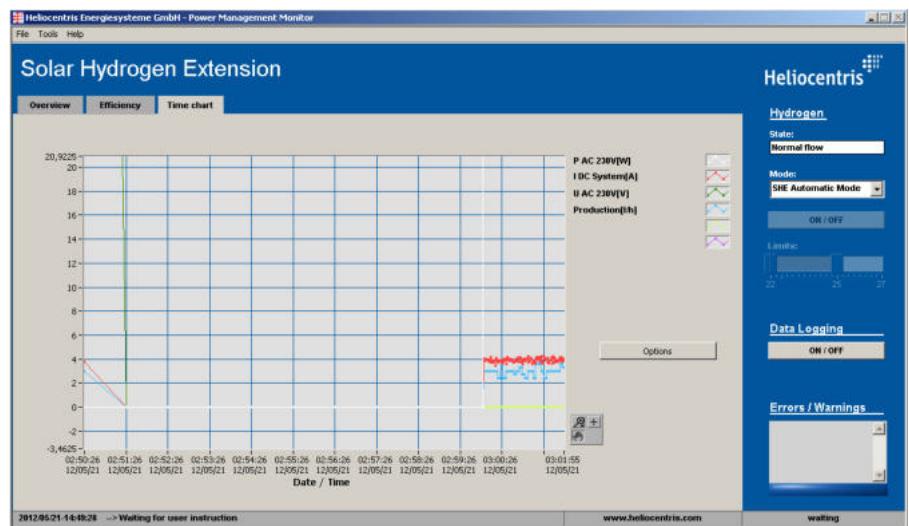

Figure 3-10: The values measured and calculated in the system can be represented graphically in the trend graph.

– See [Diagram Tab](#) on page 37

3.4.2 Electrolyzer Control Area

Status The *Status* status display indicates whether the data connection between the hydrogen generator and the software is established (*Connected*) or is interrupted (*Disconnected*). The status of the hydrogen generation is also shown: *Normal Flow, Normal Pressure, Standby*.

Function The desired operating function can be selected in the *Function* drop-down field. There are 4 operating functions available:

- Off (see [Off function](#) on page 30)
- SHE automatic (see [SHE Automatic Function](#) on page 30)
- PC automatic (see [PC Automatic Function](#) on page 31)
- PC manual mode (see [PC Manual Mode](#) on page 31)

| | |
|--|---|
| Operating the hydrogen generator manually | The hydrogen generator can be started and stopped with the Start / Stop button in the PC manual mode function mode. |
| Setting limit values for the upper and lower battery voltage | <p>The limit values for the battery voltage can be set with the slider control in PC automatic function mode:</p> <ul style="list-style-type: none"> • The lower battery voltage (Lower Battery Limit) defines the point at which the hydrogen generator is switched off to protect the battery. • The upper battery voltage defines the point at which the hydrogen generator is switched on. |

3.4.3 Data Acquisition Control Area

| | |
|-------|---|
| Start | The Start / Stop button for starting and stopping the data recording is located in the Data Acquisition control area. |
|-------|---|

3.4.4 Errors / Warnings

| | |
|---------------|--|
| Error message | Messages and errors in the SHE or the individual components are shown in the Errors / Warnings field. |
|---------------|--|

3.4.5 Menu

| | |
|------------------|---|
| File menu | The Close menu item is found in the File menu to close the software (see How to Shut Down the System on page 41). |
|------------------|---|

This menu also contains the **Print screen** menu item, which is used to send a photo of the screen to the default printer.

| | |
|--------------------|---|
| Extras menu | <p>In the Extras menu, open the Settings and Calibration menu items for the dialog for the parameterization of the software and the system.</p> <ul style="list-style-type: none"> – See How to Change Software Settings on page 32 and – How to Calibrate Sensors on page 34. |
|--------------------|---|

| | |
|------------------|--|
| Help menu | <p>The Help menu item opens the current instruction manual in PDF format.</p> <p>The About ... menu item opens a window with information about the version of SHE and the manufacturer's address; the Version menu item indicates the current software version.</p> |
|------------------|--|



TIP

Please have this information ready for any service inquiries.

3.5 Other Components

3.5.1 Hydrogen Generator

The hydrogen generator HG 72 / HG 30 enables the production of hydrogen with a purity of 6.0 for laboratory and research requirements. It is suitable for the operation of fuel cell system or for filling a metal hydride canister.



Figure 3-11 Hydrogen Generator HG 72

3.5.2 PV Sensor Kit

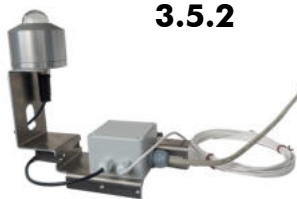

An optional PV sensor kit can be connected for the recording of the environmental temperature, module temperature and total radiation on the Solar Hydrogen Extension. The PV sensor kit is not included in the scope of delivery.

3.5.3 Metal Hydride Canister



Figure 3-12 Metal hydride canister

4 Getting Started

4.1 Scope of Delivery

| | |
|--|--|
|  | <ul style="list-style-type: none"> • 1 Power Management Cabinet • 1 Key • 1 Communication cable for connection of the hydrogen generator • 1 Ground cable 5 m • 1 Grounding clamp |
|  <p>*Exemplary illustration</p> | <ul style="list-style-type: none"> • 2 Solar batteries • Jumper • Red power cable <p>Depending on the type of delivery, the solar batteries are either already pre-assembled in the power management cabinet or packaged separately</p> |
|  | <ul style="list-style-type: none"> • 2 Solar modules pre-assembled on a rolling cart • 1 Solar module connection cable approx. 15 m • 1 Disassembly tool • 1 Compass • 2 Solar plug connectors (pre-assembled) |
| | <ul style="list-style-type: none"> • USB-Stick with Power Management Monitor Software • Network cable |



| | |
|---|--|
|  | <ul style="list-style-type: none"> • 1 Hydrogen Generator HG 72 / HG 30 • 1 Hydrogen connection with quick coupling • 1 IEC power cable |
|  | <ul style="list-style-type: none"> • Metal Hydride Canisters |
| Optional | |
|  | <ul style="list-style-type: none"> • PV Sensor Kit • Connection cable with 15-pin plug |

Table 4-1 Scope of delivery

4.2 Installation Location



WARNING

Danger of injury due to explosion!

Escaping hydrogen can ignite.

- ▶ The Solar Hydrogen Extension is intended for installation in a room corresponding to local laboratory regulations, which must be integrated into an operational safety concept with Ex-protection documentation.
- ▶ Observe the additional safety instructions from [Requirements for the Location / Installation Location](#) on page 9.

The installation location must also meet the following requirements:

- Maximum relative air humidity 80 % for temperatures up to 31 °C
- Altitude up to 2,000 meters above sea level
- Temperature range +15 °C to +30 °C
- Sufficient ventilation
- The room must comply with the locally applicable safety and laboratory regulations
- Power connections must be present
- Hydrogen sensors must be present
- Minimum space requirement for installation:
 - SHE: approx. 1 sqm floor space and opening doors

| | |
|--------------------------|--|
| | <ul style="list-style-type: none"> – Solar modules: 2x 1.5 sqm outside for installation and inside for storage, minimum door dimension is about 120 cm, maximum distance to SHE is about 15 m |
| Requirements in the room | <p>Do not block the safety valves of the metal hydride canisters.</p> <p>Align the safety valves of the metal hydride canisters so that they are not directed at persons.</p> <p>Sufficient space must be left between the rear side of the system and, e.g. a wall.</p> |
| Base | Install the system on a stable, level and solid base. |
| Safety regulations | The respective applicable national safety regulations for the installation location must be strictly complied with for the installation and operation of the hydrogen supply. This particularly applies for the use and storage of the metal hydride canisters. |

4.3 Unpacking, Installation and Connection

The Solar Hydrogen Extension is pre-assembled and delivered wrapped in film. The individual components are packaged separately.

The following section describes how to unpack the system and how to add, connect and install additional components, as well as what to pay attention to during the process. For this purpose, the following steps must be carried out:

- [Unpacking and Installation](#)
- [How to Install Solar Batteries](#)
- [How to Connect PC and Hydrogen Generator](#)
- [How to Ground the Hydrogen Extension](#)
- [How to Install, Align and Connect the Solar Module](#)
- [How to Connect the PV Sensor Kit \(Optional\)](#)

4.3.1 Unpacking and Installation



CAUTION

Danger of injury due to the heavy weight of the system and individual modules!

Lifting the system can cause back problems. If the system slips out of your hands or components fall, crushing injuries can result. Material damage can also occur.

- ▶ Always lift in a manner which is appropriate for your back.
- ▶ Wear safety shoes.
- ▶ Have 2 persons unpack and set up the unit.



CAUTION

Danger of injury due to crushing!

Carelessness while installing and uninstalling can result in crushing and abrasion of the hands.

- ▶ Wear work gloves.

- ✓ Suitable installation location
 - ✓ 2 persons wearing safety clothing (safety shoes, work gloves)
1. Unpack the individual components.
 2. Check the delivered system for visible transport damage.
 - *If applicable, document the damage using a camera and immediately inform the transport company and Heliocentris or your supplier about the damage.*
 3. Unscrew the adjusting feed from rolling components (SHE, solar modules).
 4. Install the components in a suitable location.
 5. Fix the adjusting feet.



TIP

Store packaging material for future storage or dispatch of the unit.
The cables to the solar modules cannot be extended without violating the EMC Directive.

4.3.2 How to Install Solar Batteries

Depending on the type of delivery, either the solar batteries are already preassembled, and only the jumper cable has to be connected, or batteries are individually packaged for air freight, and they must be installed in the battery cabinet and connected.

The batteries are installed in the battery module as follows:

- ✓ 2 batteries
- ✓ Fuse
- ✓ Jumper
- ✓ Red power cable
- ✓ Screwdriver SW 10



DANGER

Danger of death due to electric shock!

Voltage may be present in the Power Management cabinet.

- ▶ Make sure that the main battery switch is in the *Off* position.



CAUTION

Danger of injury due to short-circuit!

Short-circuiting of the batteries can cause severe injuries.

- ▶ Do not short-circuit the batteries.



NOTICE

Damage due to pole reversal!

Pole reversal can damage the batteries or the system.

- ▶ Make sure that the poles are correctly assigned:
 - red = +
 - black = –

Individually packaged for
air freight



Installing and connecting batteries:

1. Check that the main battery switch is in the **Off** position.
2. Open the battery cabinet with the key.
3. Unscrew the rail (1).

– Set aside the two screws for later use.

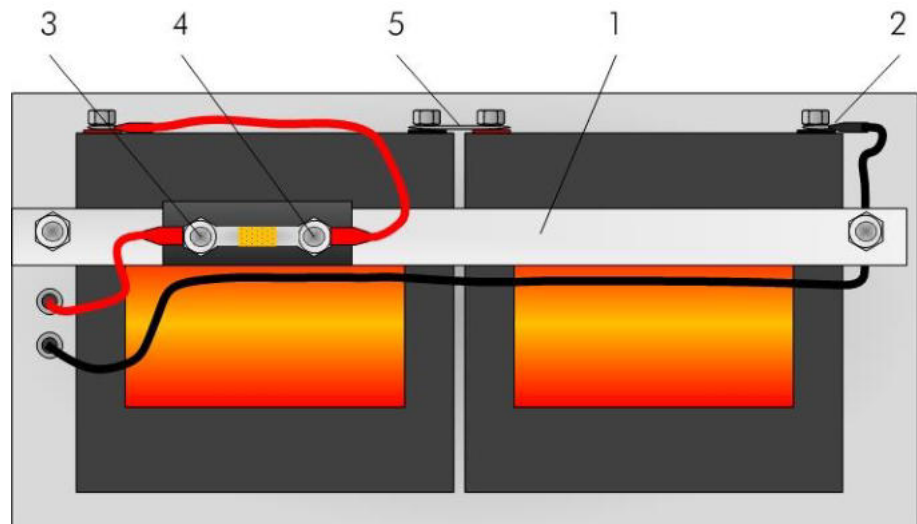

Figure 4-1 How to install and connect batteries in the Power Management cabinet

4. Adjust the batteries.
5. Fasten the rail.
6. Open the fuse on the rail.
7. Connect the black power cable to the negative pole of the battery (2).
8. Connect the red power cable to the fuse (3).
9. Use the red power cable to connect the fuse and positive pole of the battery (4).
10. Bridge the negative pole of the one battery with the positive pole of the other battery (5).
11. Close the fuse.
12. Close the cabinet with the key.

Batteries are already pre-
assembled

Connecting the jumper cable:

1. Check that the main battery switch is in the **Off** position.
2. Open the battery cabinet with the key.
3. Bridge the negative pole of the one battery with the positive pole of the other battery (5).
4. Close the cabinet with the key.

4.3.3 How to Connect PC and Hydrogen Generator



An accompanying package includes all necessary connecting elements. Compare the [Scope of Delivery](#) with the information in this instruction manual after unpacking (see page 19).

Connect the modules as follows:

- ✓ Communication cable for connection of the hydrogen generator
 - ✓ Hydrogen Generator (HG 72 or HG 30)
 - ✓ Network cable
1. Connect the hydrogen generator to AC output (3) of the Power Management cabinet.
 2. Use the communication cable to connect the Power Management Cabinet **HG COM** socket (2) with the **RS232C** socket on the hydrogen generator.
 3. Use the network cable to connect the PC and Power Management cabinet (1).
- ⇒ The hydrogen generator and PC are connected.

4.3.4 How to Ground the Hydrogen Extension



The SHE must be connected to a ground.

- ✓ Ground cable
- ✓ Washer and M8 nut
- ✓ Grounding clamp or potential equalization rail available in the laboratory
- ✓ Screwdriver SW 13

Proceed as follows to ground the SHE:

- ▶ Connect the ground cable to the ground bolt of the SHE.
- ▶ Connect the grounding clamp to a suitable ground, e.g. a pipe.
- ▶ Connect the ground bolt of the SHE to the ground clamp using the ground cable.
- ▶ Connect the ground cable to the potential equalization rail in the laboratory.

No potential equalization rail available

Potential equalization rail available

4.3.5 How to Install, Align and Connect the Solar Module

In order to ensure the most effective utilization of the solar radiation, the solar modules are movable and one can be equipped with a compass.



CAUTION

Danger of injury due to movable solar modules!

Solar modules are made for portable use and have rollers. On windy days, they can roll uncontrolledly and hurt people. When being moved, they can roll over feet and cause confusions.

- ▶ Solar modules must always be operated while under supervision

and when weather conditions are favorable, i.e. never operate them when strong wind or thunderstorms are expected.

- ▶ Only move carefully and sturdy shoes wearing.

**NOTICE****Damage due to cable break!**

The cable can tear under tension.

- ▶ Route the cable loosely.

**TIP**

The connection cables to the solar modules cannot be extended without violating the EMC Directive.

- ✓ 2 solar modules
- ✓ 1 solar module connection cable (15 m, 2-pin)
- ✓ 2 persons
- ✓ Hex key
- ✓ Compass
- ✓ Degreasing cleaner with lint-free cloth

1. Move the solar modules to the desired position.
2. Engage the parking brake on the wheel.



Figure 4-2 How to adjust the installation angle



CAUTION

Danger of injury due to the solar modules folding up!

With the hexagon socket screw loosened, the solar modules can fold together and cause crushing injuries.

- ▶ Install and connect the solar modules in pairs.

3. Hold onto the solar module.
4. Using a hex key, unscrew the adjusting screw on one side of the guide rail.
5. Then loosen the hexagon socket screw on the other side while holding the solar module in position.
6. Adjust to the desired installation angle.
7. Tighten the hex screws on both sides.
8. Repeat the process on the other solar module.
⇒ *The solar modules are installed and can be connected.*



NOTICE

Damage due to pole reversal!

Incorrect polarity can damage the system.

- ▶ Make sure that the poles are correctly assigned: red = + and black = -.



NOTICE

Damage by incorrect wiring!

Incorrect wiring can damage the system.

- ▶ Make sure that the solar panels are connected parallel.

How to connect the solar modules

9. Connect the pre-assembled solar plug connector (4) and *24 VDC Solar In* on the Power Management cabinet using the 15 m connection cable.

⇒ *The solar modules are installed and can be aligned.*

Adhering the compass

10. Clean and degrease with a cleanser the mounting location at the frame on the side of the solar module.
11. Pull the protective film off the underside of the compass.
12. Adhere the compass on the frame of the solar module.
13. Align the solar module using the compass.

4.3.6 How to Connect the PV Sensor Kit (Optional)

- ✓ PV Sensor Kit (not included in the scope of delivery)
 - ✓ 15-pin sensor kit plug
1. Insert the 15-pin plug in **Sensor** on the Power Management cabinet.
 2. Turn the plug until the black rubber seal of the socket is no longer visible.
 - ⇒ *The values recorded by the PV sensor kit are shown in the software.*

4.4 How to Install the Power Management Monitor Software on the PC

The installation of the software comprises the following steps:

- Install the Power Management Monitor Software
- Establishing communication between the PC and Solar Hydrogen Extension

**TIP**

Before you start the installation of the software, make sure that you have administrative rights on the PC or ask your administrator to install and configure the software.

4.4.1 How to Install the Power Management Monitor Software

Install the software as follows:

- ✓ System requirements
 - (see *PC requirements on page 50*)
- ✓ USB-Stick with Power Management Monitor Software
- ✓ Sufficient rights for installation of the software
 - *Contact the administrator, if necessary*

1. Switch on PC and monitor.
2. Insert the USB-Stick with Power Management Monitor Software.
The folder on the USB-Stick for the software installation is named **Software**.
3. Open the **Software** folder.
4. Run **Setup.exe**
5. Follow the instructions of the setup program.
⇒ *The program Power Management Monitor is installed.*
6. Restart the PC.

4.4.2 How to Establish Communication between the PC and Solar Hydrogen Extension

The PC and Solar Hydrogen Extension must operate in the same network segment (subnet). For this purpose, TCP/IP settings must be made on the PC.

How to Set the IP Address on the PC

The following permanent IP setting must be made on the PC:

- ▶ IP address: 172.16.60.80
- ▶ Subnet mask: 255.255.0.0
- ▶ Standard gateway: IP address (SHE) 172.16.60.81

IP Address on the SHE

The IP address on the Solar Hydrogen Extension is as follows:

- IP address (SHE): 172.16.60.81 (after delivery)
- Subnet mask: 255.255.0.0

The settings can only be changed by the Heliocentris technical support staff.

5 Operation

The SHE can be operated autonomously or using the software.



WARNING

Danger of injury due to electric shock!

Local high voltage may be present in a defective system; they can cause severe injury on contact.

- ▶ Only operate the SHE in faultless condition.

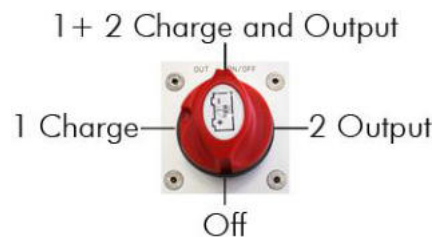

Figure 5-1 Switch positions of the main battery switch

5.1 How to Operate the SHE Autonomously

If the SHE is operated autonomously without PC, all functions are executed by the system control:

- The batteries are supplied from the solar modules.
- The hydrogen generator produces hydrogen.
- As soon as the lower limit value for the battery voltage of 22 V is reached, the hydrogen generator is switched to standby mode. If other loads are connected to the AC output of the SHE, it is shut off.
- The hydrogen generator is restarted as soon as the battery voltage returns to a level above 25 V. If other loads are connected to the DC and/or AC output of the SHE, they are switched on again.

Operate the system autonomously as follows:

- ✓ All electrical connections have been made
- ✓ Hydrogen Generator HG 72 / HG 30 switched on
- ✓ Set the main battery switch (on the side of the system) to the **1+2 (Charge and Output)** position.
- ✓ *The system is ready for operation and runs autonomously.*

5.2 How to Operate the SHE with Power Management Monitor Software

5.2.1 Off function

The **Off** function mode is the mode in which only the batteries are supplied from the solar modules. In addition, the DC output is enabled and a load can be connected.

The hydrogen generator and the AC output are switched off and cannot be switched on by the PC or the SHE automatic.

How to operate the system in **Off** mode:

- ✓ All electrical connections have been made
 - ✓ The Power Management Monitor Software is installed
1. Set the main battery switch (on the side of the system) to the **1+2 (Charge and Output)** position.
 - ⇒ *The system is ready for operation.*
 2. Start the Power Management Monitor software.
 3. Select **Off** mode in the **Function** drop-down field.
 - ⇒ *The solar load regulator supplies the batteries.*

5.2.2 SHE Automatic Function

The SHE automatic mode is the function mode without software support. All functions are executed by the SHE system control:

- The batteries are supplied from the solar modules.
- The hydrogen generator produces hydrogen.
- As soon as the lower limit value for the battery voltage of 22 V is reached, the hydrogen generator is switched to standby mode. If other loads are connected at the AC output of the SHE, both the loads and the generator are switched off.
- The hydrogen generator is restarted as soon as the battery voltage returns to a level above 25 V. If other loads are connected to the AC output of the SHE, the loads are switched on again.

How to operate the system in **SHE Automatic** mode:

- ✓ All electrical connections have been made.
- ✓ Hydrogen Generator HG 72 / HG 30 switched on
- ✓ Set the main battery switch (on the side of the system) to the **1+2 (Charge and Output)** position.
- ✓ *The system is ready for operation and runs in SHE Automatic without PC support.*
- ✓ *The hydrogen generator is started or stopped depending on the battery voltage.*



TIP The lower battery voltage level is set to 22 V and protects the batteries against total discharge.

5.2.3 PC Automatic Function

The PC automatic mode is the automatic function mode with software support. The system control of the SHE operates the system as described in [SHE Automatic Function](#). In addition, the following software functions are available:

- The limit values can be defined for the upper and lower battery voltage.

Loads can be connected to the AC output and switched on and off by the system when the appropriate battery voltage limit is reached.

How to operate the system in **PC Automatic** mode:

- ✓ All electrical connections have been made
 - ✓ Hydrogen Generator HG 72 / HG 30 switched on
1. Set the main battery switch (on the side of the system) to the **2** (Output) position.
 - ⇒ *The system is ready for operation.*
 2. Start the Power Management Monitor software.
 3. Select **PC Automatic** mode in the **Function** drop-down field.
 - ⇒ *The system is operated in automatic mode. The upper and lower battery voltage limits can be set.*
 4. Slide the slider control to adjust the limits for the upper and lower battery voltage under **Limit values**.
 - *The currently active slider control has a center line for precise adjustment. The current voltage value is also shown when you slide the control.*
 - *The difference between the upper and lower battery voltage limits must be at least 0.5 V.*
 - ⇒ *The hydrogen generator is switched off as soon as the lower battery limit is reached.*
 - ⇒ *The hydrogen generator is switched on as soon as the upper battery limit is reached.*

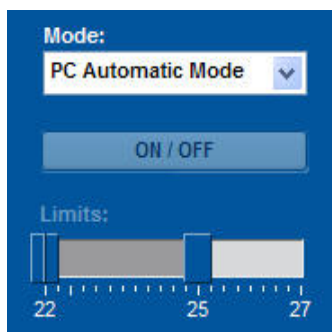

How to Set Limits for Battery Voltage

5.2.4 PC Manual Mode

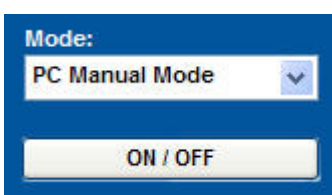

The **PC Manual Mode** is the manual function mode with software support. The hydrogen generator can be operated manually.

If other loads are connected to the system, the AC output of the SHE is switched on or off, depending on the charge status of the batteries.

How to operate the system in **PC Manual mode**:

- ✓ All electrical connections have been made
- ✓ Hydrogen Generator HG 72 / HG 30 switched on

How to operate the hydrogen generator manually

1. Set the main battery switch (on the side of the system) to the **2** (Output) position.
⇒ *The system is ready for operation.*
2. Start the Power Management Monitor software.
3. Select **PC Manual Mode** in the **Function** drop-down field.
⇒ *The hydrogen generator is switched off.*
⇒ *The system is operated in manual mode. The hydrogen generator can be switched on and off manually.*
4. Start the hydrogen generator with the **Start / Stop** button.
5. Clicking again on the **Start / Stop** button switches off the hydrogen generator.

5.2.5 How to Change Software Settings

You can change the following settings in the software:

- Save interval: Adjust the desired save interval for recording the data (e.g. 30 s: a measurement is recorded every 30 seconds).
 - *The following values can be selected: 1 s, 2 s, 5 s, 10 s, 30 s, 60 s*
- Save format: Output format for the recorded data
 - *The following file types can be selected: *.txt and *.csv*
- IP address: IP address of the available SHE system
- Port: Network port of the SHE system
- Language: German or English
- Active solar module surface: in m², this specification is required to calculate the degree of efficiency
- Electrolyzer: hydrogen generator in use - HG 72 / HG 30

You can change the software settings as follows:

1. In the *Extras* menu, select the menu item *Settings*.
⇒ *The Options dialog opens.*

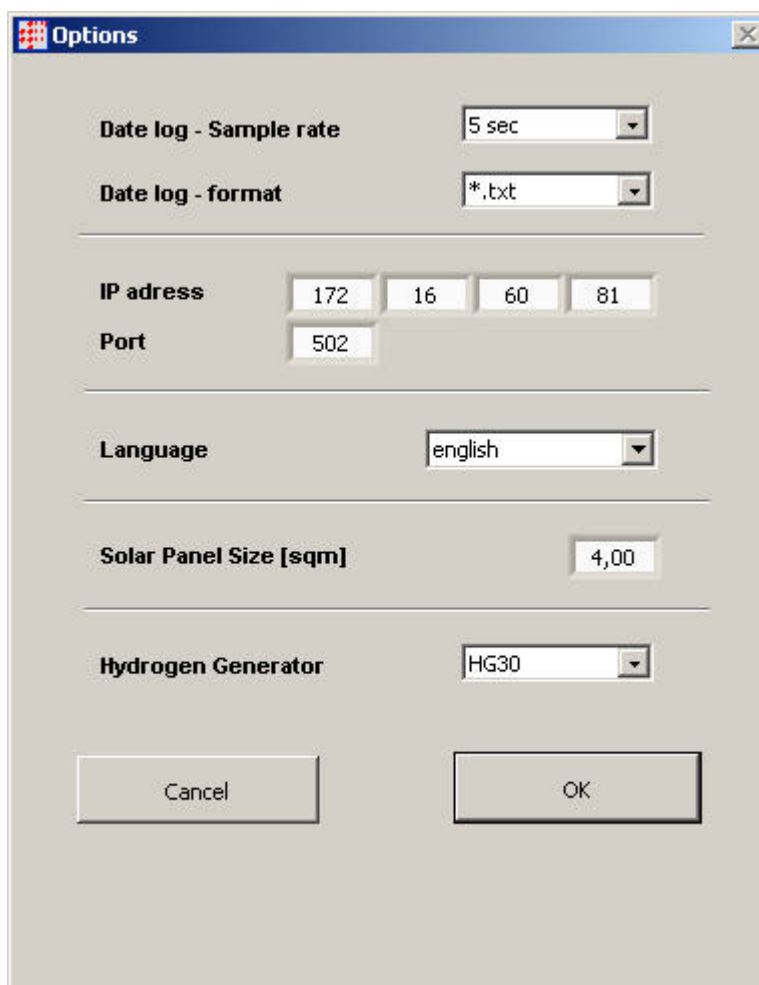

Figure 5-1 *Options* dialog

2. Change the corresponding settings in the input fields or select them in the drop-down fields.
3. Confirm with the *OK* button.
⇒ *The settings are adopted.*

5.2.6 How to Record Data

Recorded data can be saved using the software. Activate the data recording in the *Data Acquisition* control area as follows:



TIP Save interval and save format can be selected in the *Options* dialog (see [How to Change Software Settings](#) on page 32)

1. Click the **Start / Stop** button.
 - ⇒ A dialog window for the input of the save location and file name is opened and shows the existing file structure.
2. Select a folder.
3. Enter file name in the **File Name** field.
 - The default setting for the file name is:
YYYY_MM_DD_hhmmss_SHE_
4. Confirm with the **OK** button.
 - ⇒ The window closes. The data recording begins.

How to stop
Data Acquisition

- Proceed as follows to stop the recording:
- ▶ Click the **Start / Stop** button again.
 - ⇒ The data recording stops.

5.2.7 How to Calibrate Sensors

All measurement points can be checked for adherence to their tolerances and adjusted as necessary.

You can calibrate the sensors as follows:

1. In the **Extras** menu, select the menu item **Calibration**.
 - ⇒ The **Calibration** dialog opens.
2. Click on the button for the appropriate sensor.
 - ⇒ The **Please type calibration value** dialog opens.

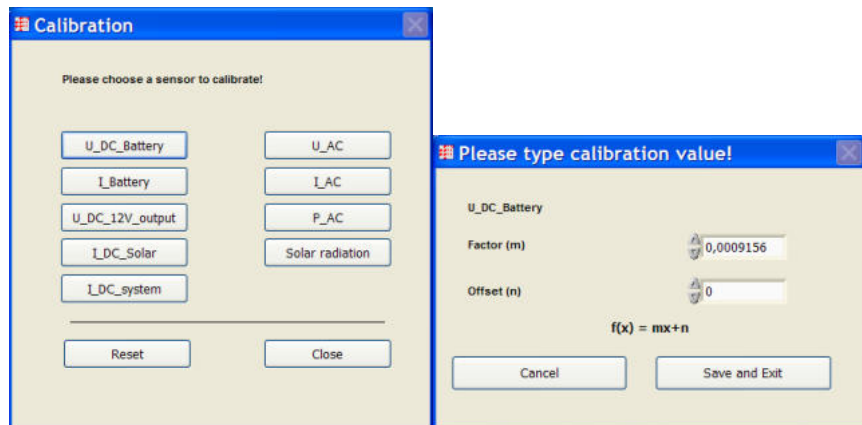

Figure 5-2 **Calibration** and **Please type calibration value** dialogs

3. Check values and correct, if necessary.
4. All values can be reset to the factory setting:
5. In the **Please type calibration value** dialog, click on the **Reset** button.

How to
Reset Changes

5.2.8 How to End Software

Proceed as follows to close the software:

1. In the **File** menu, select the menu item **Close**.
2. Follow the instructions.

⇒ Any data recording that is still active is stopped automatically and the software is closed. The Solar Hydrogen Extension switches back to automatic mode after the software is closed.

5.3 Overview Tab

The **Overview** view is the default view on startup. The system overview is shown as a simplified flow diagram within the Solar Hydrogen Extension.

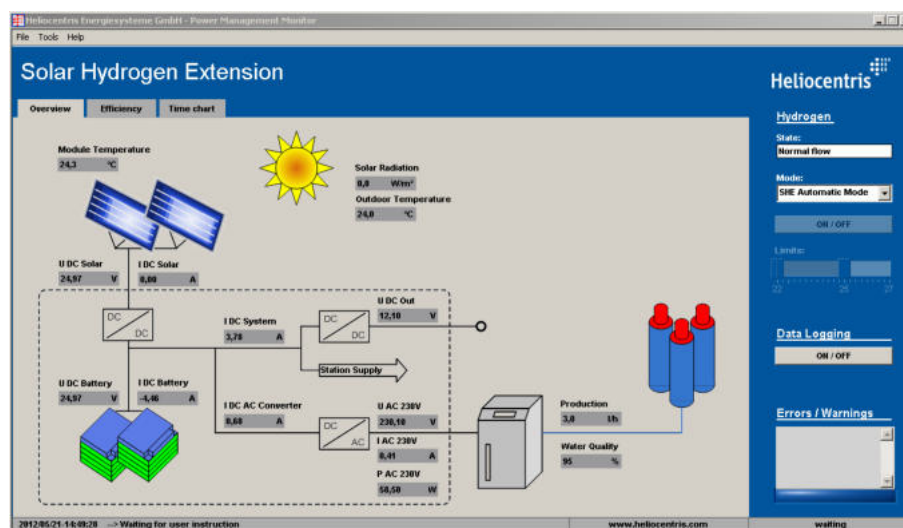

Figure 5-3 Overview

This view shows the current values of the operating parameters and other information.

| Area | Parameter | Definition | Units / states |
|-----------------|--------------|--|----------------|
| Solar Modules | U DC Solar | Output voltage | V |
| | I DC Solar | Output current | A |
| Battery | U DC battery | Battery voltage | V |
| | I DC battery | Input and output current | A |
| DC/DC Converter | I DC system | Output current to the DC output and for internal consumption | A |
| | I Inverter | Output current to the AC output | A |
| DC/DC Converter | U DC Out | Output voltage at the DC output | V |

| Area | Parameter | Definition | Units / states |
|---|-----------------|---------------------------------|--------------------|
| DC/AC | U AC | Output voltage at the AC output | V |
| | I AC | Output current at the AC output | A |
| | P AC | Output power at the AC output | P |
| Hydrogen Generator | | Production | l / h |
| | | Water quality of the DI water | % |
| PV Sensor Kit Data only available when connected | | Module temperature | °C |
| | Solar radiation | Total radiation | W / m ² |
| | | Outside temperature | °C |

Table 5-1 Parameters of the view *Overview* according to modules

5.4 Degree of Efficiency Tab

The *Degree of Efficiency* view represents the power balancing of the complete system.

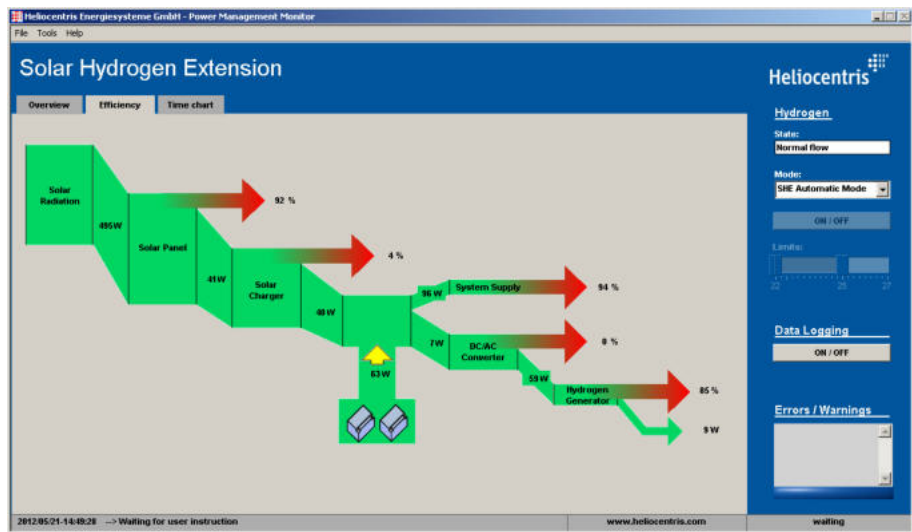

Figure 5-4 Power balancing of the complete system

The diagram shows efficiency and losses (in percent) of the complete system and its individual components (display is not scaling).

An arrow point up or down in the area of the batteries indicates whether the batteries are being charged or discharged.

If the PV Sensor Kit is connected to the Solar Hydrogen Extension, the total radiation on the solar module and its degree of efficiency are taken into consideration and shown in the software. If the kit is not connected, the global radiation is not taken into consideration and the degree of efficiency is taken into account beginning with the output power of the solar module.

5.5 Diagram Tab

The *Diagram* view shows the progression of individual measures and calculated values over time. In the process, relationships between various process sizes can be easily detected.

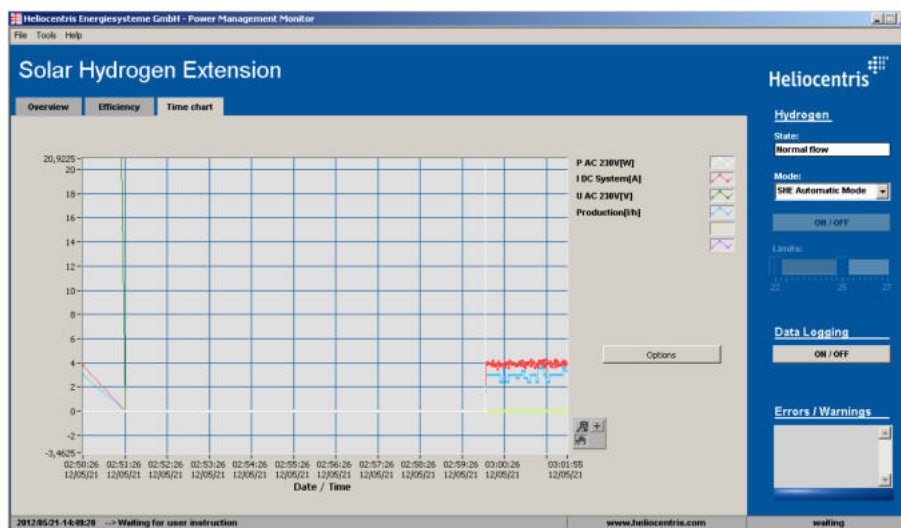

Figure 5-5 *Diagram* view



How to Change the Appearance of the Diagram

Using the buttons to the bottom right, the appearance of the diagram can be changed.

How to Change the size

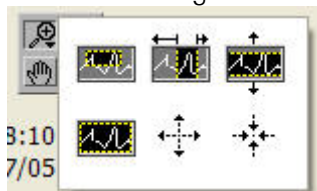

How to Change the Time Curve of the Diagram

Clicking on the magnifying glass opens various options for enlarging or reducing the size of the image (from left to right).

- ✓ *Deactivate Autoscaling X* and *Autoscaling Y* in the *Autoscaling* context menu
- Zoom in on selection
- Zoom in on X-axis
- Zoom in on Y-axis
- Back to presetting
- Zoom out
- Zoom in

The time curve of the diagram can be changes as follows:

1. Click on the hand.
2. Holding the left mouse button, slide the diagram in the desired direction.

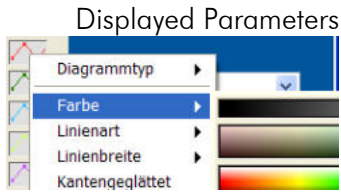

How to Parameterize the Diagram Display

The parameters shown in the diagram are specified in the legend on the upper right.

The type of representation of the graphs can be changed using the context menu. This change is not saved. When the software is restarted the graphs display their presetting again.

The display of the diagram can be parameterized as follows:

1. Click on the **Settings** button (2).
2. The **Graph Display options** dialog opens.

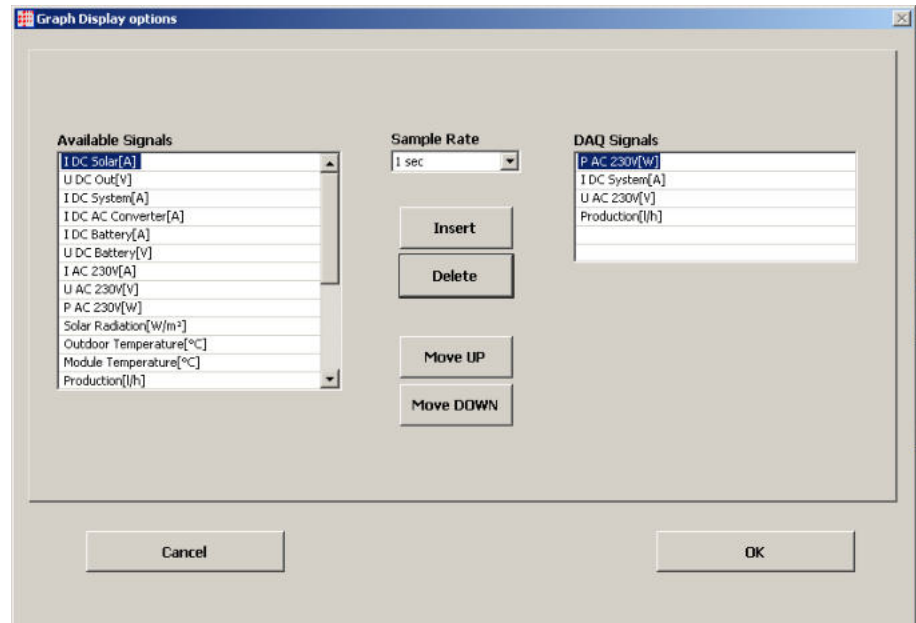

Figure 5-6 **Graph Display options** dialog

Select parameters

3. In the left **Available Signals** column, select the parameters to be displayed.
4. By clicking on the **Insert** button move them to the **DAQ Signals** column.
 - ⇒ *The parameters in the right column are shown in the diagram. Up to six parameters can be selected.*
5. Select the desired sampling interval in the **Sample Rate** drop-down menu.

How to Change the Sequence

You change the sequence of the parameters in the **DAQ Signals** column and thus the sequence of their representation in the diagram as follows:

6. Select parameters.
7. Move the parameters up one position by clicking on the **Move Up** button.
8. or
9. Move the parameters down one position by clicking on the **Move Down** button.

How to Remove Parameters from the Display

Remove a parameter from the selection as follows:

10. Select the parameter in the DAQ signals column.
11. Remove the parameter from the display by clicking on the **Delete** button.

6 Decommissioning

The necessary steps for the decommissioning and disassembly of the product, as well as the conditions for its packaging, storage and transport are described in this chapter.

6.1 How to Shut Down the System



DANGER

Danger of death due to explosion!

Hydrogen can escape unnoticed from incorrectly stored metal hydride canisters and create a potentially explosive mixture.

- ▶ Metal hydride canisters may not be stored on the system. After decommissioning, they must be stored in accordance with applicable regulations.
- ▶ Store metal hydride canisters in a separate cylinder cabinet (ideally outside the building) or a fireproof hood with hydrogen monitor.
- ▶ Integrate the storage concept into the operational safety concept.



NOTICE

Damage to the hydrogen generator from incorrect decommissioning!

If the sequence of the decommissioning is incorrect, the hydrogen generator can be damaged.

Batteries can be deeply discharged, if main battery switch is not in position *Off*.

- ▶ Follow the correct sequence.

Proceed as follows to shut down the system:

✓ Disassembly Tool

1. Select the **Off** function in the software.
 - ⇒ *The hydrogen generator switches to standby.
Wait 10 seconds until the HG makes a purch-sound.*
2. Switch off the hydrogen generator with the main switch.
3. Disconnect the quick coupler of the hydrogen generator from the hydrogen drain.
4. Disconnect the communication of the hydrogen generator and SHE.
5. Disconnect the voltage supply of the hydrogen generator.
6. Turn the main battery switch on the system to the **Off** position.
 - ⇒ *The message **No connection to the SHE** appears in the **Errors /warnings** software field.*
7. Close the software with the menu **File>Close**.
 - ⇒ *The short-term decommissioning is finished.*

In order to decommission the SHE for an extended period of time or to store or ship it, proceed as follows:

8. If applicable, disconnect the communication to the PV Sensor Kit.
9. Disconnect the solar modules from one another with the disassembly tool.



CAUTION! Danger of injury due to rolls! Move solar modules carefully and sturdy shoes wearing.

10. Bring solar modules to a safe place.
11. Disconnect the communication of the SHE and PC.
12. Disconnect all other electrical connections and supply lines from the SHE.
13. Remove the safety cap from the battery fuse.
14. Disconnect the battery fuse.
 - ⇒ *The system is decommissioned.*



6.2 How to Store the System



NOTICE

Damage due to incorrect storage conditions!

Excessive moisture will lead to corrosion and short circuits during later operation.

- ▶ Ensure proper storage conditions.
- ▶ Pack components.

- ✓ The system is decommissioned.
- ▶ Store the system according to Table 6-1 Storage conditions.

| Storage Conditions | Specification |
|--|---|
| Temperature range (optimal) Possible for a short period | +15 °C...+30 °C -10 °C ... +15 °C; 30 °C ... 40 °C |
| Relative air humidity | Maximum relative air humidity 80 % for temperatures up to 31 °C |
| Environmental conditions | Dry, dust free, no reactive chemicals and no direct and long term sunlight |

Table 6-1 Storage conditions

6.3 How to Ship the System

If the system or individual modules are to be shipped, it must first be decommissioned and then packed in the original packaging.

The locally applicable transport regulations must be observed.

When packing the individual components, they must be sufficiently padded to protect them against impact and fast acceleration.

The system may only be transported in the upright position. During transport, the system should not be exposed to freezing temperatures or excessive heat for extended periods. A temperature range of -10...+40 °C

6.4 How to Uninstall the Software

To uninstall the software, use the integrated software management functions in the Windows operating system.

1. In **Start > Control panel** open the **Software** folder.
⇒ *The Software dialog opens with a list of the installed software.*
2. Select the **Power Management Monitor** software.
3. Click the **Remove** button.

7 Maintenance and Service

7.1 Serial Number & Service

Each Solar Hydrogen Extension has a serial number that is printed on the shipping carton (on the nameplate) and on the delivery note / invoice.

The module's serial number is located on the back of each module on its nameplate.

Please keep this serial number available so that the Heliocentris service team can easily and effectively help you.

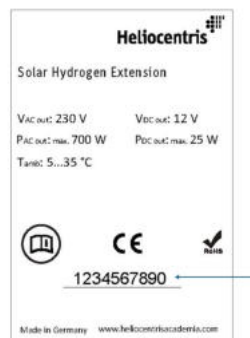

Figure 7-1: A serial number on the nameplate of a module.

7.2 Maintenance

To ensure maximum system performance and to prevent loss of efficiency, proceed as follows:

- ▶ Regularly operate the system with the solar modules in the sunshine at least once a month for one hour.
- ▶ Charge batteries 2 to 3 times a year. Batteries discharge when not in use.



CAUTION

Danger of injury due to ignition of hydrogen!

As the result of damaged hydrogen hoses or leaky connections, hydrogen can escape and ignite with the presence of an ignition source.

- ▶ Close hydrogen supply.
- ▶ Disconnect unit from power supply. Replace damaged hoses.



NOTICE

Damage due to short circuits!

Short circuit due to damaged cables.

- ▶ Disconnect unit from power supply or battery. Replace damaged cables.

- ▶ Inspect the condition of hoses and cables at least every half year and check connections for leaks and to make sure they are tightly connected.

- ▶ The gel batteries are maintenance-free and do not require testing.

All maintenance must be carried out by persons qualified for this work. In addition, the operator is responsible for ensuring that all maintenance is performed in accordance with the local occupational safety regulations.

7.3 Cleaning

- ✓ Moist cloth

1. Disconnect the system from the power supply.
2. Clean the solar module and Power Management housing with a lightly moistened cloth.



TIP

In case the unit is extremely dirty, use a mild detergent; never use chemical cleaners.

7.4 Service

If problems with the system should arise, specify the hardware and software version (see **Help** menu on page 17) when contacting:

Heliocentris Academia International GmbH

Rudower Chaussee 30

12489 Berlin, Germany

Tel. + 49 (0) 30 340 601 600

www.heliocentrisacademia.com

Email: service@heliocentrisacademia.com

An employee from Heliocentris Customer Service will contact you and explain all further steps. If you return the unit for repair or replacement, you must ship the unit sufficiently secured and packaged.

Heliocentris is not responsible for damage which has been caused by improper packaging and / or improper shipment. You must bear the costs yourself for the shipment of units with expired warranty.

7.5 Disposal



System

Never dispose of the system with household waste. In accordance with the the WEEE Directive 2012/19/EU, electronic equipment must be sent to the designated collection point for recycling.

Batteries

Never dispose of batteries with household waste.

- ▶ Totally Discharge batteries.
- ▶ Seal battery poles with a strong piece of tape.
- ▶ Drop off used batteries at the designated collection point.

Packaging material

- ▶ If required, store packaging material for future storage of the system.
- ▶ Dispose of packaging material that is no longer needed in accordance with local laws and regulations.

Outside the European Union

Dispose of system in accordance with local laws and regulations.

7.6 Warranty

Heliocentris assumes a warranty of one year for the system.

The warranty only covers defects which are present at the time of the handover of the product from the seller to the purchaser.

A warranty for specific characteristics (e.g. power and service life of the fuel cell) is not made.

With proper operation a minimum service life of 1,500 hours can be expected, which is guaranteed by Heliocentris.

Warranty claims against Heliocentris cannot be made if:

- The customer has caused the damage by improper use or incorrect operation
- Unauthorized repairs or manipulations have been made to the product
- The customer has neglected his duty of supervision and has caused damage to third parties

The supplier is liable for damage caused during the delivery to the customer and provides replacement in the case of damage.

In the case of complaints and return of the product, the risk is borne by the customer who must provide proper and secure packaging.

8 Technical Data

8.1 Complete System

| Designation | Specification |
|------------------------|-----------------------|
| Dimensions (W x H x L) | 43 cm x 67 cm x 70 cm |
| Weight | 84 kg |

Table 8-1 Specifications of the complete system

8.2 Power Management Cabinet

| Designation | Specification |
|------------------------------------|----------------------|
| Max. input current, solar module | 30 A |
| System voltage, photovoltaics | 24 V DC |
| Max. output voltage of DC output | 12 V DC |
| Max. output current of DC output | 2 A |
| Max. continuous power of AC output | 700 W |
| Momentary peak load | 1,050 W (for 10 sec) |

Table 8-2 Power Management cabinet specifications

8.3 Batteries

| Designation | | Specification | |
|-------------------------------|------|---|---------|
| Type | | Gel battery (lead acid solar battery, maintenance-free) | |
| Capacity | | 55 Ah | |
| Rated voltage | | 12 V | |
| Dimensions (W x H x L) | | 13.8 cm x 21 cm x 22.8 cm | |
| Weight | | 17.5 kg | |
| Recommended temperature | | 20 °C | |
| Permissible temperature range | | Max. -10 °C...+40 °C | |
| Capacity in Ah | C 20 | 1.80 V / C | 55 Ah |
| | C 10 | | 46 Ah |
| | C 5 | 1.75 V / C | 41.5 Ah |
| | C 1 | 1.65 V / C | 34.5 Ah |
| Maintenance-charge voltage | | 2.27 V / C | |

| Designation | Specification |
|-----------------------------|---------------------|
| Internal resistance Ri mOhm | 6.5 |
| Ik in A | 1,700 |
| Number of pins | 2 |
| Connection type | Insert screw pin M6 |
| Quantity | 2 |
| Fuse | BFSM 1125 |

Table 8-3 Battery specifications

8.4 Solar Module

Please note: Details are subject to change. These are conventional market standards.

| Designation | Specification |
|-------------------------|---|
| Type | Polycrystalline / Monocrystalline |
| Max. power | > 500 W |
| Operation temperature | -40°C bis 85°C |
| Reverse current feed Ir | 30,0 A |
| No-load voltage | 40 V |
| MPP voltage | > 30 V |
| STC | 800 Watt/m ² at Cell temperature 20° |
| Short circuit current | Approx. 15,5 A |
| Max. system voltage | 1.500 VDC |
| Dimensions | Approx. 1762 mm x 1134 mm x 30 mm |
| Weight | Approx. 25 kg |
| Reliability | After 30 years (87,4 % power) |
| MPP output | > 400 Wp |
| Efficiency | Approx. 22,52 % |
| MPP Courant | > 8 A |
| Quantity | 2 units |

Table 8-4 Solar module specifications

8.5 PC requirements

| Designation | Specification |
|----------------------------------|----------------------------|
| Operating system | Windows 11 |
| Processor | 64-bit, ≥ 1 GHz, ≥ 2 cores |
| Ports | 1 free network interface |
| RAM | > 4 GB |
| Hard disk space for installation | > 1 GB |

| Designation | Specification |
|--------------------|--------------------------|
| Monitor resolution | FULL-HD 1920x1080 pixels |

Table 8-5 PC hardware requirements

8.6

Hydrogen generator HG 30

| Designation | Specification |
|-------------------------|---------------------------------------|
| Type | PEM |
| Production rate | 30 nl/h |
| Hydrogen quality | >6.0 (99.99999 %) |
| Installed power (max) | 450 W |
| Dimensions rack | 19" 4U – 48 cm deep |
| Outlet pressure | 16 bar |
| Operating temperature | 15 °C to 40 °C |
| Input voltage | 100 or 240 V AC / 50-60 Hz (variable) |
| Weight | 22Kg |
| Necessary water quality | < 1µS/cm, deionized or distilled |

Table 8-6 Hydrogen generator HG 30 specifications

8.7

Hydrogen generator HG 72

| Designation | Specification |
|-------------------------|---------------------------------------|
| Type | PEM |
| Production rate | 72 nl/h |
| Hydrogen quality | >6.0 (99.99999 %) |
| Installed power (max) | 560 W |
| Dimensions rack | 19" 4U – 48 cm deep |
| Outlet pressure | 16 bar |
| Operating temperature | 15 °C to 40 °C |
| Input voltage | 100 or 240 V AC / 50-60 Hz (variable) |
| Weight | 25Kg |
| Necessary water quality | < 1µS/cm, deionized or distilled |

Table 8-7 Hydrogen generator HG 72 specifications

9 Appendix

Abbreviations

| Abbreviation | Meaning |
|--------------|--|
| PV | Photovoltaics |
| SHE | Solar Hydrogen Extension |
| TCP/IP | Transmission Control Protocol and Internet Protocol. TCP/IP is a protocol combination which connects the transport and network layers form the OSI layer model. |
| C | Cell |

Table 9-1 Overview and explanation of the abbreviations used in the operating manual and in the supplied software

Safety Data Sheet Hydrogen

The safety data sheet is available here: [GESTIS Substance Database](#).

Index

| | | | |
|----------------------|----|------------------------|----------------------|
| A | | G | |
| Abbreviations | 53 | Ground cable | 19 |
| B | | Grounding clamp | 19 |
| Batteries | | H | |
| connection | 23 | Help | 17 |
| installing | 22 | Hydrogen connection | 20 |
| Technical data | 50 | Hydrogen generator | |
| Battery cabinet | 13 | operate manually | 32 |
| Battery voltage | | Technical data | 51 |
| set limits | 31 | Hydrogen Generator | 18 |
| C | | I | |
| Cleaning | 46 | IEC power cable | 20 |
| Communication | | Installation | 20 |
| establishing | 28 | Installation location | 9 |
| Communication cable | 19 | K | |
| Compass | 19 | Key | 19 |
| Connection cable | | M | |
| PV Sensor Kit | 20 | Maintenance | 45 |
| solar module | 19 | Measured data | see Data acquisition |
| D | | Menu | 17 |
| Data acquisition | 33 | Metal hydride canister | |
| stopping | 34 | optional | 18 |
| Data recording | | N | |
| Software | 17 | Network cable | 19 |
| Decommissioning | 41 | O | |
| long-term | 42 | Off function | 30 |
| short-term | 42 | Overview | 35 |
| Degree of efficiency | | software view | 35 |
| Software view | 36 | Owner/Operator | 9 |
| Diagram | | P | |
| change appearance | 37 | Packaging material | 47 |
| software view | 37 | PC Automatic Function | 31 |
| Disassembly | | PC hardware | |
| tool | 19 | requirements | 51 |
| Disposal | 47 | PC Manual Mode | 31 |
| E | | | |
| Error | | | |
| Message, Software | 17 | | |

| | | | |
|---------------------------|-------------|----------------------|-------------|
| Power Management Cabinet | 11 | Technical data | 50 |
| Power-Management-cabinet | | Solar Module | 14 |
| Technical data | 49 | Solar plug connector | 19 |
| PV Sensor Kit | 18 | Storage | 42 |
| install | 27 | System Control | 13 |
| | | | |
| S | | T | |
| Screen photo | 17 | Technical Data | 49 |
| Screenshot | 17 | Timechart | see Diagram |
| Sensors | | Transport | 43 |
| calibration | 34 | Transport damage | 22 |
| Service | 46 | | |
| SHE | | U | |
| Components | 11 | Unpacking | 21 |
| connection | 24 | Use | |
| grounding | 24 | non-approved | 8 |
| shipping | 43 | User | 10 |
| Technical data | 49 | User interface | |
| SHE Automatic Function | 30 | SHE | 12 |
| Shipment | 43 | | |
| Software | 14 | V | |
| changing settings | 32 | Version | 17 |
| Electrolyzer control area | 16 | | |
| end | 17, 35 | W | |
| installation | 27 | Warnings | 6 |
| uninstalling | 43 | Warranty | 47 |
| Solar Battery | see Battery | | |
| Solar module | | | |
| connection | 26 | | |
| installation | 24 | | |



Heliocentris Academia International GmbH

Rudower Chaussee 30
12489 Berlin, Deutschland
Tel. + 49 (0) 30 340 601 600
service@heliocentrisacademia.com
www.heliocentrisacademia.com