

RENEWABLE ENERGY TRAINING SET EXPERIMENT BOOKLET

Elect.- Tchr. Hasan SORGUNLU

Elec.-Elect. Eng. Alperen HALICI



ABSTRACT

In this booklet, we explain widely used renewable energy production methods. Our set is designed to teach the methods of electrical energy production using Solar Energy, Wind Energy, and Hydrogen Fuel Cells. To facilitate use in applied courses in Technical Education, we provide detailed instructions through visual drawings on how to conduct experiments. The booklet outlines how to generate electrical energy using these three energy sources and describes the methods used during production, testing, and experimentation.

The experiments are presented in a straightforward manner, progressing from the simplest to the most complex. The booklet is interactive, with designated spaces for recording data during experiment construction.

CONTENTS

ABSTRACT	2
CONTENTS.....	3
1. Renewable Energy Training Set.....	6
2. Modules.....	7
2.1 Light Angle Adjustable Solar Panel.....	7
2.2 Wind Turbine Module.....	8
2.3 Fuel Cell Module.....	9
2.4 Monophase Switching Module.....	10
2.5 Energy Distribution Module.....	11
2.6 DC Power Supply.....	12
2.7 Solar Charge Regulator Module.....	13
2.8 Accumulator Module.....	14
2.9 Diode Module.....	15
2.10 PC Interface Module.....	16
2.11 Analog Measurement Module.....	17
2.12 AC/DC Measurement Module.....	18
2.13 AC Energy Analyser Module.....	19
2.14 Isolated Measurement Module.....	20
2.15 Potentiometer Module.....	21
2.16 Electronic Potentiometer Module.....	22
2.17 Electronic Load Module.....	23
2.18 Lamp Module (12V DC).....	24
2.19 Lamp Module (220V AC).....	25
2.20 Light Source Control Module.....	26
2.21 Off-Grid Inverter Module.....	27

2.22	On-Grid Inverter Module	28
2.23	Electronic Electricity Meter Module.....	29
2.24	Solar Panel Simulator Module.....	30
2.25	Wind Simulator Module.....	31
2.26	Wind Turbine Charge Controller Module	32
2.27	Data Acquisition Module.....	33
3.	Photovoltaic Energy Systems.....	34
4.	Applications of Photovoltaic Training Kit	36
4.1	Experiment-1 Measurement of Photovoltaic Panel Open Circuit Voltage.....	36
4.2	Experiment-2 Measurement of Photovoltaic Panel Short Circuit Current.....	40
4.3	Experiment-3 Photovoltaic Panel Current-Voltage Characteristics	44
4.4	Experiment-4 Examination of the No-Load Outputs of the Photovoltaic Panel Depending on the Sun's In-Day Movement	50
4.5	Experiment-5 Examination of the Photovoltaic Panel's Loaded Outputs Depending on the Sun's In-Day Movement.....	55
4.6	Experiment-6 Examination of the No-Load Outputs Due to the Season Change of the Photovoltaic Panel.....	58
4.7	Experiment-7 Examination of the Loaded Outputs Due to the Season Change of the Photovoltaic Panel.....	63
4.8	Experiment-8 Examination of the Series Connection of Photovoltaic Panel.....	66
4.9	Experiment-9 Examination of the Parallel Connection of Photovoltaic Panel.....	72
4.10	Experiment-10 Examination of Shadow Effect in Photovoltaic Panel.....	77
4.11	Experiment-11 Examination of Effect of Bypass Diode in Photovoltaic Panels.....	83
4.12	Experiment-12 Examination of Solar Panel Simulator	92
4.13	Experiment-13 Examination of Mismatching Effect in Photovoltaic Panels.....	104
4.14	Experiment-14 Examination of the Effect of Blocking Diode in Photovoltaic Panels .	108
4.15	Experiment-15 Direct Load Connection to Photovoltaic Panels	112
4.16	Experiment-16 No-Load Commissioning of Off-Grid Inverter.....	116
4.17	Experiment-17 Installation of a Basic Photovoltaic System with DC Load.....	120

4.18	Experiment-18 Installation of a Basic Photovoltaic System with AC Load.....	124
4.19	Experiment-19 Examination of Off-Grid Inverter Output Signal with DAQ Module	128
4.20	Experiment-20 Examination of Measurement of Off-Grid Inverter Output Signal with Energy Analyser.....	131
4.21	Experiment-21 Measurement of Energy Received from Off-Grid Inverter.....	134
4.22	Experiment-22 Examination of On-Grid Invertor.....	137
5.	Wind Energy Systems	140
6.	Applications of Wind Energy Training Kit.....	142
6.1	Experiment-1 Examination of the Relation between Wind Speed and Turbine Operation	142
6.2	Experiment-2 Oscilloscope Examination of Variable Load Wind Turbine Charge Control System	147
6.3	Experiment-3 Examination of Variable Load Wind Turbine Charge Control System with Battery	153
6.4	Experiment-4 Examination of Wind Turbine Output Voltage with DAQ Module	158
7.	Hydrogen Energy Systems.....	162
8.	Applications of Hydrogen Energy Training Kit.....	164
8.1	Experiment-1 Examination of Hydrogen Fuel Cell Output Voltage with Oscilloscope	164
8.2	Experiment-2 Examination of Hydrogen Fuel Cell Output Voltage Under Load with Oscilloscope	167
8.3	Experiment-3 Examination of Output Voltage from Hydrogen Fuel Cell DC/DC Converter using an Oscilloscope.....	172
8.4	Experiment-4 Examination of Hydrogen Fuel Cell DC/DC Converter Output Voltage Under Load with Oscilloscope	175

1. Renewable Energy Training Set



Figure-1. Components of Renewable Energy Training Set

The Renewable Energy Training Set is a computer-assisted training tool designed for conducting experiments on the generation of electrical energy from solar, wind, and hydrogen fuel cell resources. This versatile set consists of modular components, enabling a wide range of experiments using the same modules.

In the design of these modules, careful attention has been given to utilizing industrial-grade components that are currently employed in the field. The entire system has been developed with a focus on aligning with educational environments and methodologies, prioritizing ease of use, safety, expandability, and modularity.

2. Modules

2.1 Light Angle Adjustable Solar Panel



Figure-2. Module Image

Model Number	RES-03
Weight	2,8kg
V _{oc}	2 x 23,8V
I _{sc}	2 x 0,6A
LED Projector Voltage	0-36V
LED Projector Power	300W
Connecting Terminals	4mm Binding Post
Operating Temperature	0-55°C (0-131°F)

Table-1

To conduct photovoltaic experiments, the module includes two 12W-12V-0.6A monocrystalline photovoltaic panels and 300W LED Projector. To simulate the seasonal and daily movements of the sun, the module can be adjusted both horizontally and vertically, and the light intensity can be adjusted to facilitate experiments under different illumination levels.

The module is constructed using a 45x45 aluminum profile and is equipped with lockable wheels, allowing for easy mobility within the classroom. Module connections are established using 4mm binding posts, and there is also an earth connection to ensure safety during use. Figure 2 provides a visual representation of the module, and Table 1 outlines its features.

2.2 Wind Turbine Module



Figure-3. Module Image

Model Number	RES-002a
Weight	16kg
DC Motor Input	24V
DC Motor Speed	1400rpm
Dynamo Operating Voltage	24V
Dynamo Power	300W
Nominal Wind Speed	13m/s
Connecting Terminals	4mm Binding Post
Operating Temperature	0-55°C (0-131°F)

Table-2

To conduct wind energy experiments, this module features a 12V-300W AC three-phase turbine, which consists of a 24V-1400rpm DC motor capable of simulating wind speed in a controlled environment. The motor's speed, which replicates wind conditions, is adjustable. The dynamo shafts are connected using a compatible coupling.

This module is securely mounted on an aluminum pole with lockable wheels, ensuring stability and ease of transportation within the classroom environment. Module connections are established using 4mm binding posts, and safety is maintained through the inclusion of an earth connection. Figure 3 provides a visual representation of the module, and Table 2 details its features."

2.3 Fuel Cell Module

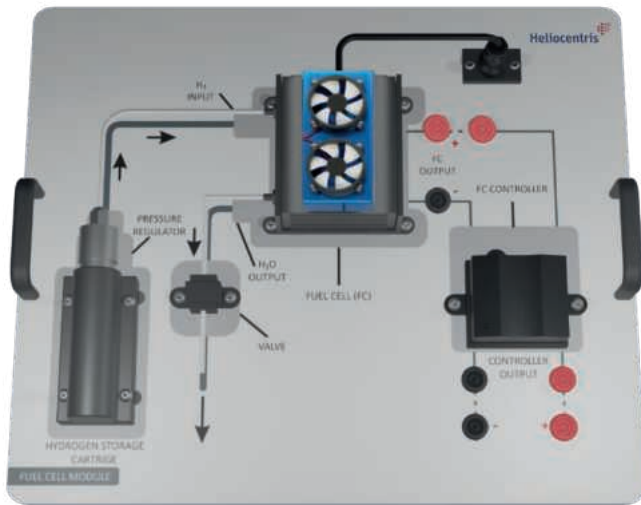

Figure-4. Module Image

Model Number	RES-027
Weight	3kg
Tank Pressure	30 Bar
F.C. Input Pressure	0,4-0,55 Bar
F.C. Output Voltage	14 V _{DC}
Con. Output Voltage	11,8V _{DC}
Connecting Terminals	4mm Binding Post
Operating Temperature	0-55°C (0-131°F)

Table-3

The PEM Cell package and controller are utilized to convert electrical energy from stored hydrogen for conducting Hydrogen Energy experiments. Hydrogen separation is achieved using the HYDROFILL PRO refueling station, with the separated hydrogen stored in the HYROSTIK PRO fuel storage tank at 30 bar (435 PSI). A regulator, connected to the tank outlet, reduces the pressurized hydrogen to 0.4-0.55 bar before it is supplied to the PEM cell package.

The H-30 PEM fuel cell within the 30W package converts hydrogen into electrical energy, providing an output of 8.4V-3.6A. To ensure optimal performance, the cell requires the use of the output controller, which maintains an output voltage of 11.8V. Periodically, the hydrogen compressed in the cell is discharged through the outlet valve, controlled by the controller. Additionally, the controller enhances operating performance by momentarily short-circuiting the cell every 10 seconds.

Fans integrated into the cell package prevent overheating and aid in oxygenating the cell package. All these components come together in the Hydrogen Fuel Cell Module, with module connections established using 4mm binding posts. Figure 4 provides a visual representation of the module, and Table 3 outlines its features.

2.4 Monophase Switching Module

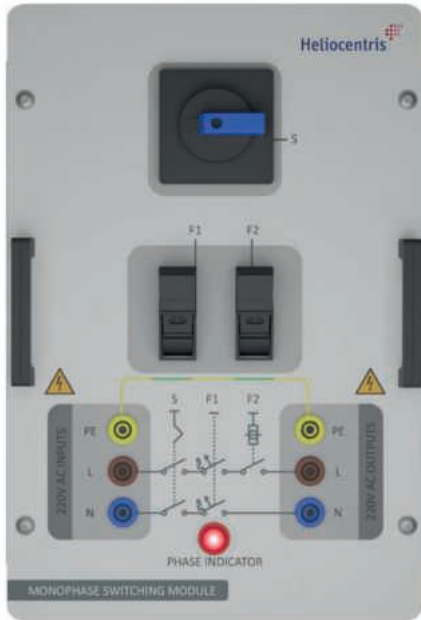

Figure-5. Module Image

Model Number	RES-012
Weight	3kg
Braker	10A
Tesidual Current Relay	25A – 30mA
Connecting Terminals	4mm Binding Post
Operating Temperature	0-55°C (0-131°F)

Table-4

This module serves the purpose of switching power on and off during experiments. For the safety of both personnel and equipment, the module is equipped with an on-off switch, a residual current relay, and a circuit breaker. It is highly recommended to use this module before the Energy Distribution module to ensure safety during work.

Module connections are made using 4mm binding posts. Figure 5 provides a visual representation of the module, and Table 4 details its features.

2.5 Energy Distribution Module

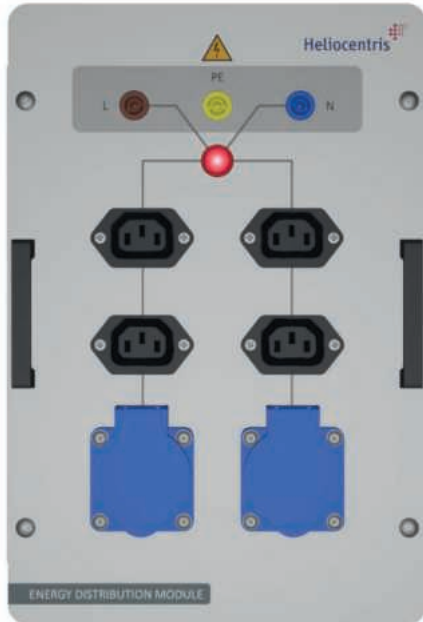

Figure-6. Module Image

Model Number	RES-013
Weight	2,8kg
Input	4mm Binding Post
Output	4 pcs. IEC Socket 2 pcs. Industrial Socket
Operating Temperature	0-55°C (0-131°F)

Table-5

This module is used to distribute energy to other modules within the training set. The energy input is connected via a 4mm binding post. The module features four IEC connectors and two industrial sockets. Its power status can be easily observed through the module's LED indicator.

Module connections are established using 4mm binding posts. Figure 6 provides a visual representation of the module, and Table 5 outlines its features.

2.6 DC Power Supply



Figure-7. Module Image

Model Number	RES-032
Weight	5kg
Operating Voltage	220V / 50Hz
Output Voltage	0-32 V _{DC} ± 10mV
Output Current	0-5,1 A _{DC} ± 1mA
Output Power	0-160W
Connecting Terminals	4mm Binding Post
Operating Temperature	0-55°C (0-131°F)

Table-6

This module is designed to provide the external DC power supply required for experiments. It offers programmability through the built-in OLED color LCD screen, making function settings easily accessible via the rotary encoder. All changes made in real-time are reflected in the output. To prevent inadvertent changes during experiments, a screen lock function is available, and a pre-setting function prevents unwanted limit overruns.

The module also features protection against short circuits and high current. It offers an output voltage range of 0-32VDC with a ±10mV resolution, and the output current value can be set between 0-5.1ADC with a ±1mA resolution on the LCD screen. Instantly observe the current value drawn from the source and the voltage value at the load on the LCD screen.

Module connections are established using 4mm binding posts. Figure 7 provides a visual representation of the module, and Table 6 outlines its features.

2.7 Solar Charge Regulator Module



Figure-8. Module Image

Model Number	RES-022
Weight	2,5kg
System Input Voltage	12V / 24V Automatically
Charge /Discharge Current	10A
Battery Types	LiFePo4-Lithium
Connecting Terminals	4mm Binding Post
Operating Temperature	0-55°C (0-131°F)

Table-7

This module utilizes smart PWM technology to charge batteries with the energy received from the solar panels. Additionally, it offers the option to connect DC loads directly. The module's charge regulator features automatic 12V/24V recognition technology, allowing for the application of panel voltages of up to 50 volts.

Module connections are established using 4mm binding posts. Figure 8 provides a visual representation of the module, and Table 7 outlines its features.

2.8 Accumulator Module

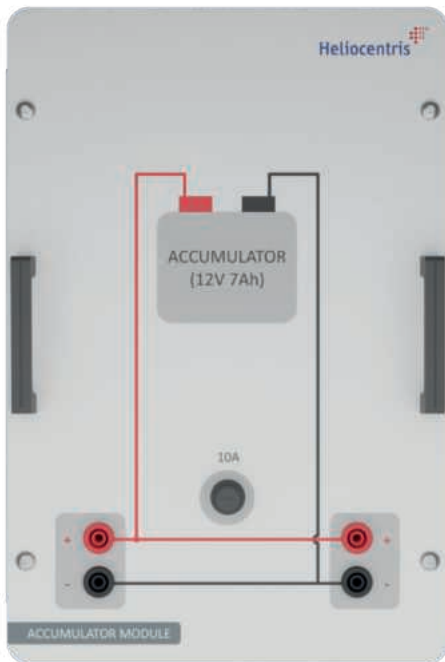

Figure-9. Module Image

Model Number	RES-007
Weight	2kg
Voltage	12V
Capacity	10Ah
Connecting Terminals	4mm Binding Post
Operating Temperature	0-55°C (0-131°F)

Table-8

The module has a rated current and voltage of 12V/10Ah. It is equipped with a Battery Management System (BMS) and features a package structure made from Li-ion battery cells. To protect the module from short circuits, an external glass fuse is included.

For proper experimentation, it's essential to ensure that the battery is charged. The BMS controls the charge and discharge of the package. To charge the module, set the DC Power Supply Module to 15V with a current of 1.5A. Connect the positive terminal of the module to the corresponding positive terminal of the Accumulator Module and the negative terminal to its negative terminal. If the Accumulator Module is not yet charged, you will observe a charging current displaying. The BMS control ensures that charging continues until the Accumulator Module is fully charged, at which point the BMS will cut off the current. Regularly repeating this process ensures the long life of the Accumulator Module.

When the module reaches the lower limit of its battery capacity, the BMS will cut the circuit current for safety.

Module connections are established using 4mm binding posts. Figure 9 provides a visual representation of the module, and Table 8 outlines its features.

2.9 Diode Module

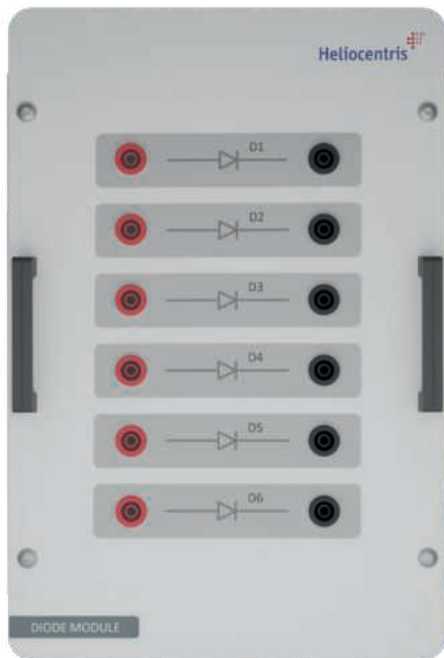

Figure-10. Module Image

Model Number	RES-019
Weight	2,1kg
Connecting Terminals	4mm Binding Post
Operating Temperature	0-55°C (0-131°F)

Table-9

The diode module includes six independent 40V/3A Schottky diodes, each of which can be used according to the experimental requirements. Module connections are established using 4mm binding posts. Figure 10 provides a visual representation of the module, and Table 9 outlines its features.

2.10 PC Interface Module



Figure-11. Module Image

Model Number	RES-016
Weight	2,7kg
Operating Voltage	220V / 50Hz
PC Connection	USB port
Data Collection Entry	4 x RS485 – RJ45
Connecting Terminals	4mm Binding Post
Operating Temperature	0-55°C (0-131°F)

Table-10

This module controls the training set modules through computer software designed for seamless integration. It communicates with the computer via the USB port and communicates with the other four peripheral modules using the RS485 protocol. The connection connectors are of the RJ45 type.

The connectors used for specific modules are as follows:

- EA: Energy Analyser Module communication connector
- MM: AC/DC Measurement Module communication connector
- EP/EL: Electronic Pot / Electronic Load Modules communication connector

Additionally, there are two analog outputs available for controlling peripheral modules:

- LS: Light Source Control Module connection connector
- WS: Wind Simulator Module connection connector

The module is equipped with a fuse to protect against overcurrent and an LED to indicate its power status. Figure 11 provides a visual representation of the module, and Table 10 outlines its features.

2.11 Analog Measurement Module

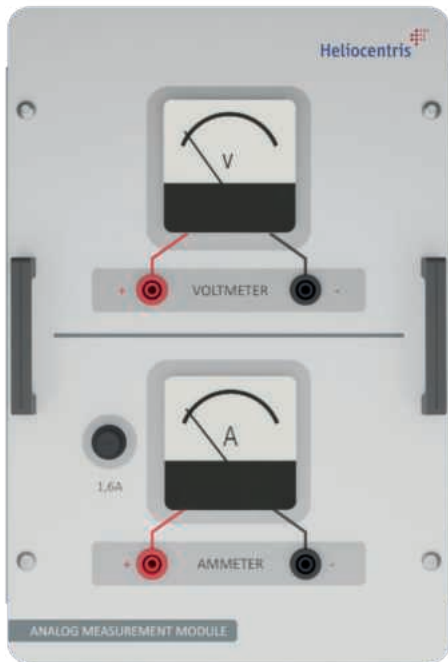

Figure-12. Module Image

Model Number	RES-008
Weight	3kg
Voltmeter Measure Range	0-30V
Ammeter Measure Range	0-5A
Connecting Terminals	4mm Binding Post
Operating Temperature	0-55°C (0-131°F)

Table-11

This is a general-purpose module consisting of one Voltmeter and one Ammeter. When using measuring instruments, it's important to make connections while considering the measurement ranges and current directions to avoid any issues. For the safety of the ammeter, an external glass fuse is included in the module.

Module connections are established using 4mm binding posts. Figure 12 provides a visual representation of the module, and Table 11 outlines its features.

2.12 AC/DC Measurement Module



Figure-13. Module Image

Model Number	RES-017
Weight	3,2kg
Operating Voltage	220V / 50Hz
AC/DC Ammeter Measure Range	0-5000mA ± 4mA
AC/DC Voltmeter Measure Range	0-500 V ± 400mV
LCD Colour Touch Screen	5 inch / HMI TFT / 800x480
Connecting Terminals	4mm Binding Post
Operating Temperature	0-55°C (0-131°F)

Table-12

The AC/DC Measurement Module has been developed for conducting precise measurements during experiments. The results of each measurement are displayed on a 5-inch TFT LCD screen. This module is versatile, capable of measuring both AC and DC values. The user can easily select which type of measurement to perform through touchscreen controls on the screen.

Furthermore, to ensure accurate measurements, the Voltmeter and Ammeter chassis are insulated from each other. The data collected is transmitted to the computer via the Computer Interface Module, utilizing the RS485 remote connection function. To transfer data to the computer, simply connect the (MM) RJ45 type connector to the appropriate port on the Computer Interface Module.

For safety, a fuse is utilized to protect the ammeter input from overcurrent. Additionally, the module itself is equipped with a fuse to safeguard against overcurrent, and an LED indicator displays its power status. Module connections are established using 4mm binding posts. Figure 13 provides a visual representation of the module, and Table 12 outlines its features.

2.13 AC Energy Analyser Module



Figure-14. Module Image

Model Number	RES-015
Weight	3kg
Operating Voltage	220V / 50Hz
Input Voltage	230V
Input Current	5A
Measurement Accuracy	$\pm 1\%$
Connecting Terminals	4mm Binding Post
Operating Temperature	0-55°C (0-131°F)

Table-13

This module is designed for the purpose of measuring AC Current, AC Voltage, Apparent Power, Real Power, and Power Factor during experiments. The results of each measurement are prominently displayed on a 5-inch TFT LCD screen. In understanding the efficiency of electrical energy, it's essential to consider the amount of apparent power that can be effectively utilized as energy. This means that the quality of electrical energy significantly depends on the elimination of non-linear components.

The Energy Analyser Module monitors the electrical energy acquired in experiments and tracks the angle difference and power loss caused by non-linear components. The collected measurements are efficiently transferred to the computer via the RS485 remote connection feature, facilitated by the PC Interface Module. To transmit data to the computer, simply connect the (EA) RJ45 type connector to the corresponding port on the PC Interface Module.

For added safety, the module is equipped with a fuse to safeguard against overcurrent, and an LED indicator displays its power status. Module connections are established using 4mm binding posts. Figure 14 offers a visual representation of the module, and Table 13 provides an overview of its features.

2.14 Isolated Measurement Module



Model Number	RES-011
Weight	3,5kg
Operating Voltage	220V / 50Hz
Voltage Measure Range	0-500V
Measurement Scale	0-5V / 0-50V / 0-500V
Current Measure Range	0-5A
Number of Channels	2
Connecting Terminals	4mm Binding Post
Operating Temperature	0-55°C (0-131°F)

Table-14

Figure-15. Module Image

The module offers both electrical and optical isolation between the load and the signal source, ensuring secure and precise measurements. Additionally, it facilitates measurements with a differential probe or a split-chassis oscilloscope. This two-channel module enables simultaneous analysis of load voltage and load current.

The module's design adheres to specific principles. Therefore, when using the X1, X0.1, and X0.01 stages for signal attenuation, the data displayed on the oscilloscope screen should be multiplied by the appropriate coefficients to obtain accurate readings.

For safety, the module is equipped with a fuse to protect against overcurrent, and an LED indicator displays its power status. Module connections are established using 4mm binding posts and BNC connectors. Figure 15 provides a visual representation of the module, and Table 14 outlines its features.

2.15 Potentiometer Module



Model Number	RES-005
Weight	3,1kg
Adjustable Resistance Value	0-1 K Ω
Maximum Resistance Power	200W
Connecting Terminals	4mm Binding Post
Operating Temperature	0-55°C (0-131°F)

Table-15

Figure-16. Module Image

The Potentiometer Module has been designed as a manually adjustable analog load for use in experiments. The module features a 1K Ω / 500W potentiometer that can be precisely adjusted by hand to various resistance values.

From the module, you can achieve:

- A maximum of 5A across the 0-50 ohms range.
- A maximum of 2A across the 51-200 ohms range.
- A maximum of 600mA across the 201-1K ohms range.

It's important to set up the experiments in a way that ensures safe circuit current flow during operation. Module connections are established using 4mm binding posts. Figure 16 provides a visual representation of the module, and Table 15 outlines its features.

2.16 Electronic Potentiometer Module



Figure-17. Module Image

Model Number	RES-004
Weight	4,5kg
Operating Voltage	220V / 50Hz
Adjustable Resistance Value	0-1000Ω
Accuracy	± 1Ω
Maximum Resistance Power	50W
LCD Colour Touch Screen	5 inch / HMI TFT / 800x480
Connecting Terminals	4mm Binding Post
Operating Temperature	0-55°C (0-131°F)

Table-16

The Electronic Potentiometer Module is designed as an electronically adjustable load for use in experiments. Module settings can be easily configured through a 5-inch TFT LCD screen with touch functionality. The module allows for electronic adjustment of resistance values between 0 ohms and 1000 ohms in 1-ohm increments, with a $\pm 1\%$ tolerance. Fine and coarse adjustment options are available within the menus.

Additionally, the module can perform sweeps between entered resistance values at specified time intervals via the interface. All settings, including remote control, can be managed from a computer using the RS485 remote connection function, facilitated by the PC Interface Module. When used with a computer, simply connect the (EP) RJ45 type connector to the corresponding port on the PC Interface Module.

For added safety, the module is equipped with a fuse to protect against overcurrent, and an LED indicator displays its power status. Module connections are established using 4mm binding posts. Figure 17 provides a visual representation of the module, and Table 16 outlines its features.

2.17 Electronic Load Module



Figure-18. Module Image

Model Number	RES-031
Weight	3,1kg
Operating Voltage	220V / 50Hz
Input Voltage	Max. 24V DC
Current Range	1mA – 1000mA
Maximum Power	24W
LCD Colour Touch Screen	5 inch / HMI TFT / 800x480
Connecting Terminals	4mm Binding Post
Operating Temperature	0-55°C (0-131°F)

Table-17

The Electronic Load Module is designed as an electronically adjustable constant current source for use in experiments. Module settings can be easily configured through a 5-inch TFT LCD screen with touch functionality. Using the touch screen and the intuitive interface, the module allows for precise adjustment of the current to be supplied to the load, enabling users to set the desired value.

When connecting the module to the power source being tested, it's essential to pay attention to the direction of the current flow. At this stage, the module ensures that the current remains constant even if the voltage produced by the source being tested varies. The module has a maximum input voltage of 24V and can handle a maximum current of 1000mA.

All settings, including remote control, can be conveniently adjusted from a computer using the RS485 remote connection function, facilitated by the PC Interface Module. When used with a computer, simply connect the (EL) RJ45 type connector to the corresponding port on the PC Interface Module. For added safety, the module is equipped with a fuse to protect against overcurrent, and an LED indicator displays its power status. Module connections are established using 4mm binding posts. Figure 18 provides a visual representation of the module, and Table 17 outlines its features.

2.18 Lamp Module (12V DC)

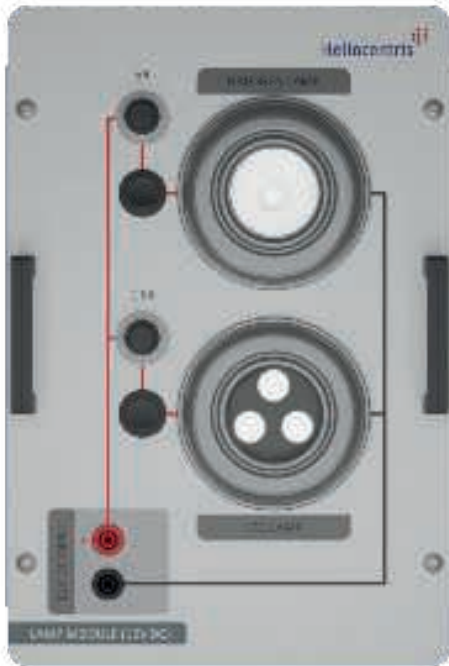

Model Number	RES-010
Weight	2,9kg
Operating Voltage	12V _{DC}
Halogen Bulb	20W
LED Bulb	2W
Connecting Terminals	4mm Binding Post
Operating Temperature	0-55°C (0-131°F)

Table-18

Figure-19. Module Image

This versatile load module features both a halogen bulb and an LED bulb. The two lamps can be controlled independently, and each lamp is equipped with a fuse to protect against high current values. It's crucial to ensure that the 12VDC operating voltage is not exceeded to prevent damage to the lamps. Additionally, please note that the lamps can become hot during operation.

Operating under 12VDC, these two lamps draw approximately 4.5A of current. Module connections are established using 4mm binding posts. Figure 19 provides a visual representation of the module, and Table 18 outlines its features.

2.19 Lamp Module (220V AC)



Model Number	RES-009
Weight	2,8kg
Operating Voltage	220V / 50Hz
Bulb Type	Saving Light Bulb LED Bulb
Bulb Socket	E27
Connecting Terminals	4mm Binding Post
Operating Temperature	0-55°C (0-131°F)

Table-19

Figure-20. Module Image

This versatile load module features both an energy-saving bulb and an LED bulb. The two lamps can be controlled independently, and each lamp is equipped with a fuse to protect against high current values. It's crucial to ensure that the 220VAC operating voltage is not exceeded to prevent damage to the lamps. Additionally, please note that the lamps can become hot during operation.

Operating under 220VAC, these two lamps draw approximately 0.22A of current. Module connections are established using 4mm binding posts. Figure 20 provides a visual representation of the module, and Table 19 outlines its features.

2.20 Light Source Control Module



Figure-21. Module Image

Model Number	RES-014
Weight	3,1kg
Operating Voltage	220V / 50Hz
Output Power	0-300W
Output Voltage	0-36V
Connection Terminals	4mm Binding Post
Operating Temperature	0-55°C (0-131°F)

Table-20

The Light Source Control Module is designed to work in conjunction with the Light Angle Adjustable Solar Panel Module for laboratory experiments. The Light Angle Adjustable Solar Panel Module features a 300W LED projector, essential for conducting photovoltaic experiments. To ensure precise and accurate experimentation, it's necessary to adjust the intensity of this light source, and that's where the Light Source Control Module comes into play.

This module allows for solar simulation within a laboratory environment, offering a light intensity range of 0-100000 lux. Users can switch between manual and PC mode using a two-position switch. In manual mode, the light intensity is adjusted through the potentiometer on the module, while in PC mode, the light intensity can be controlled via the PC Interface Module. For computer use, simply connect the RJ45 connector to the appropriate port on the PC Interface Module.

For added safety, the module is equipped with a fuse to protect against overcurrent, and an LED indicator displays its power status. Module connections are established using 4mm binding posts. Figure 21 provides a visual representation of the module, and Table 20 outlines its features.

2.21 Off-Grid Inverter Module

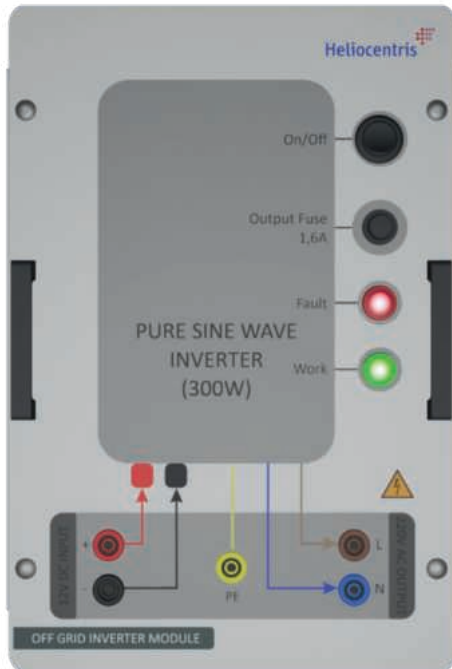

Figure-22. Module Image

Table-21

Model Number	RES-021
Weight	3,5kg
Input Voltage	12V _{DC}
Output Voltage	220-240V AC \pm 5%
Output Frequency	50Hz \pm 5%
Output Power	Full Sine- 300W
Connection Terminals	4mm Binding Post
Operating Temperature	0-55°C (0-131°F)

The Off-Grid Inverter Module has the capability to operate independently from the grid. It efficiently converts a 12V DC input voltage into a 220V-240V AC / 50Hz full sine signal. The module is equipped with an on/off switch and an energy indicator in the form of a green LED. Additionally, it features a red LED and a buzzer to indicate fault conditions.

In the event of a malfunction, the module provides the following indications:

- Low voltage switch-off protection: LED light and buzzer beep 3 times intermittently.
- Input high voltage protection: LED light and buzzer beep 4 times intermittently.
- Over-temperature protection: LED light and buzzer beep 5 times continuously.
- Overload protection: LED light and buzzer beep 3 times continuously.
- Short circuit protection: LED light and the module switches on and off.

It's crucial to avoid connecting the inputs in reverse to ensure safe and proper operation. The module includes an earth connection and output fuse for added safety. Module connections are established using 4mm binding posts. Figure 22 provides a visual representation of the module, and Table 21 outlines its features.

2.22 On-Grid Inverter Module

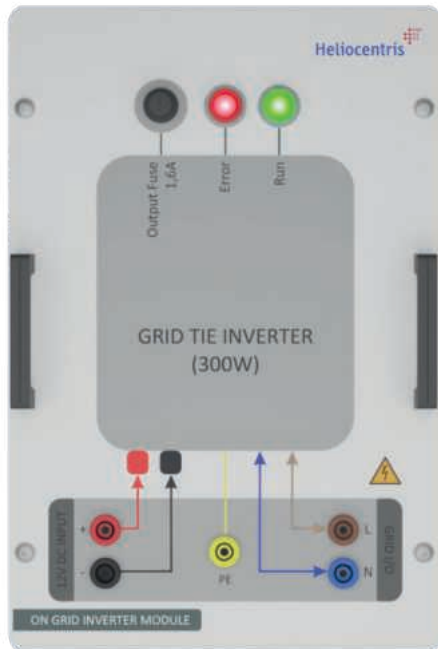

Figure-23. Module Image

Model Number	RES-020
Weight	3.5kg
Input Voltage	11-32V _{DC}
MPPT Voltage	15-22V
Input Current	Max. 18A _{DC}
Output Voltage	230V (190-260V) AC
Output Frequency	50Hz/60Hz Automatic
Output Power	Full Sine- Max. 330W
Connection Terminals	4mm Binding Post
Operating Temperature	0-55°C (0-131°F)

Table-22

The Grid-Dependent Inverter Module is designed with grid-dependent functionality and initiates operation after automatic synchronization with the phase of the mains it is connected to. It effectively converts an 11-32V DC input voltage to a 230V (190-260V) AC / 50-60Hz full sine signal. Its versatile design allows it to work with various DC power sources, including direct solar panels, wind turbines, and battery packs, utilizing the MPPT (Maximum Power Point Tracking) feature to efficiently convert and export power to the grid. When connecting to the grid, it is highly recommended to use a bidirectional smart meter for optimal performance and monitoring.

Once the module is connected and operating in accordance with the input-output values, both the Red and Green LEDs will illuminate. Subsequently, the Red LED will turn off, followed by the Green LED flashing rapidly to indicate the inverter's MPPT operation. If the Green LED remains on for an extended period, it signifies that the Maximum Power Point has been locked.

For safety, the inverter is equipped with short-circuit, low voltage, high voltage, and high-temperature protection features. Module connections are established using 4mm binding posts. Figure 23 provides a visual representation of the module, and Table 22 outlines its features.

2.23 Electronic Electricity Meter Module

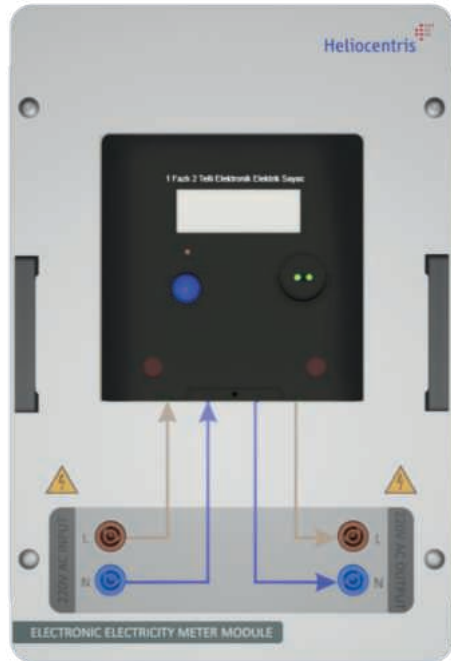

Figure-24. Module Image

Model Number	RES-028
Weight	2.7kg
Nominal Voltage	220V or 230V
Operating Voltage Range	150V ~ 300V
Frequency	50Hz
Reference Current	5A
Max. Current	100A
Counter Battery Voltage	3V
Battery Life	10 Years
Communication	RS485
LCD Screen	9(6+3) digits
Connection Terminals	4mm Binding Post
Operating Temperature	0-55°C (0-131°F)

Table-23

This module includes a bidirectional single-phase electronic meter specifically designed for industrial use. Its bidirectional functionality allows for precise measurement of electricity flow in both directions, providing accurate monitoring of time-dependent energy returned to the grid.

In addition to bidirectionality, this device offers several advanced features:

- It divides each day into 8 distinct periods for detailed energy tracking.
- The meter records energy consumption during 4 different tariffs.
- Separate programming is possible for weekdays, Saturdays, and Sundays, enabling tailored usage tracking.
- A notable feature is its ability to store data without requiring additional energy, thanks to its indelible memory.

Module connections are established using 4mm binding posts. Figure 24 provides a visual representation of the module, and Table 23 outlines its features.

2.24 Solar Panel Simulator Module

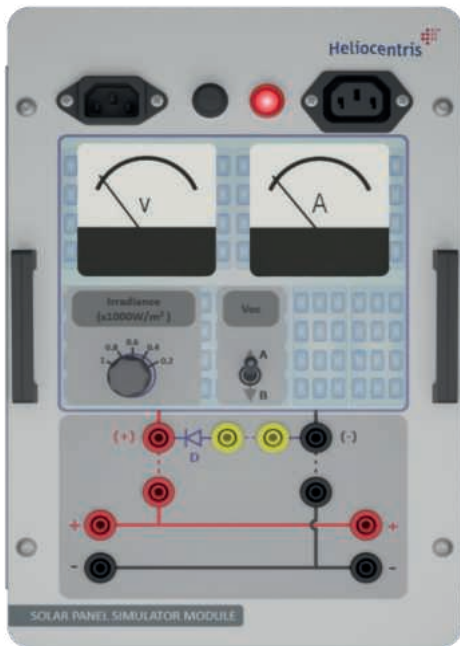

Model Number	RES-006
Weight	2.9kg
Operating Voltage	220V / 50Hz
Short circuit current	2 A
Open Circuit Voltage	12V- 18V
Irradiance Adjustment	5 Stage
Connection Terminals	4mm Binding Post
Operating Temperature	0-55°C (0-131°F)

Table-24

Figure-25. Module Image

The Solar Panel Simulator Module replicates solar panel performance within closed environments where direct solar energy operation is not feasible. It is designed for simulating the series connection or parallel connection of solar panels and incorporates a bypass diode to clearly demonstrate its effects.

Key features of this module include:

- Two analog measuring instruments to monitor current and voltage levels.
- A switch that facilitates the testing of both 12V and 18V panels.
- A five-step commutator that allows experiments with adjustable solar irradiance rates, ranging from 100% to 20% as needed.

For added safety, the module is equipped with a fuse to protect against overcurrent, and an LED indicator displays its power status. Module connections are established using 4mm binding posts. Figure 25 provides a visual representation of the module, and Table 24 outlines its features.

2.25 Wind Simulator Module



Figure-26. Module Image

Model Number	RES-002b
Weight	3kg
Operating Voltage	220V / 50Hz
Control Power	200W
Output Voltage	0-20V
Connection Terminals	4mm Binding Post
Operating Temperature	0-55°C (0-131°F)

Table-25

The Wind Simulator Module regulates the speed of the engine used for wind simulation in laboratory experiments with the Wind Turbine Module. It features a two-mode switch that allows users to choose between Manual and PC operation.

In manual mode, adjustments to the engine speed are made using the potentiometer on the module. When switched to PC mode, engine speed adjustments can be controlled through the PC Interface Module. To utilize the PC control option, it's essential to connect the (WS) RJ45 type connector to the appropriate connector on the PC Interface Module.

For added safety, the module is equipped with a fuse to protect against overcurrent, and an LED indicator displays its power status. Module connections are established using 4mm binding posts. Figure 26 provides a visual representation of the module, and Table 25 outlines its features.

2.26 Wind Turbine Charge Controller Module

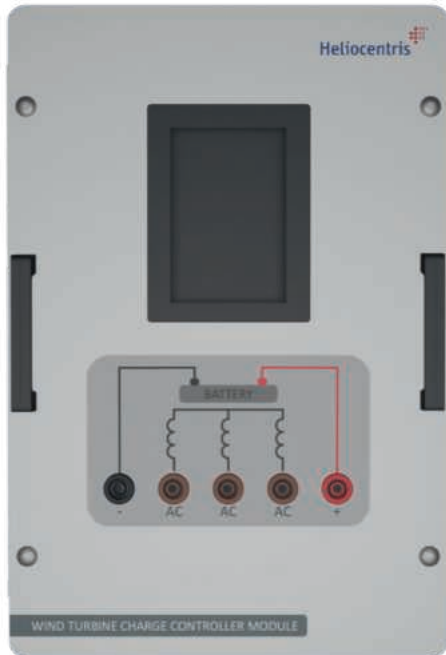

Figure-27. Module Image

Model Number	RES-002c
Weight	2,6kg
Battery Voltage Range	12 / 24V
Turbine Brake voltage	15 / 30V
Connection Terminals	4mm Binding Post
Operating Temperature	0-55°C (0-131°F)

Table-26

This module serves the purpose of converting the AC voltage produced by the dynamo of the Wind Turbine Module into DC voltage. The AC input sockets of the module receive 3-phase AC voltage generated by the dynamo.

The module plays a crucial role in rectifying the 3-phase AC voltage generated by the rotational power of the wind in the dynamo windings, making it possible to convert it into DC voltage. This DC voltage can then be used to power devices or charge a battery.

In cases where wind speeds increase significantly, the module also has a safety feature that initiates braking of the engine to prevent damage to the turbine.

Module connections are established using 4mm binding posts. Figure 27 provides a visual representation of the module, and Table 26 outlines its features.

2.27 Data Acquisition Module

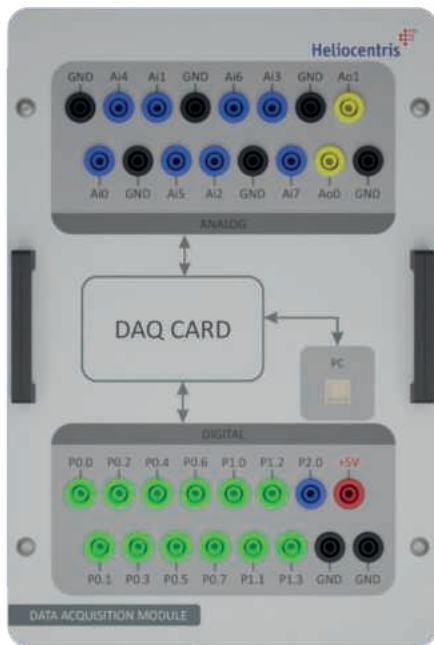

Figure-28. Module Image

Model Number	RES-018
Weight	3kg
8 pcs analog inputs (14 bits, 20 kS/s)	
2 pcs static analog outputs (12 bit, 9.1 mV)	
12 digital inputs / outputs	
Digital counter and USB connection	
Connection Terminals	4mm Binding Post
Operating Temperature	0-55°C (0-131°F)

Table-27

This module utilizes the NI6008 DAQ (Data Acquisition) card, manufactured by a reputable National company. This card provides the capability for high-speed data transfer to a computer through a USB interface. The DAQ card is versatile, accepting input data from both analog and digital sensors, and it processes and analyzes this data using the computing power of the connected computer.

Key features of the DAQ card include:

- Analog to Digital Conversion (ADC) for precise measurement of analog data.
- Reading and triggering of digital data.
- Generation of output data.
- The ability to capture instantaneous and clear data, enhancing the efficiency of experiments and tests.
- 12-bit measurements in differential connections.
- A sampling rate of 10KS/s for accurate data acquisition.

Module connections are established using 4mm binding posts. Figure 28 provides a visual representation of the module, and Table 27 outlines its features.

3. Photovoltaic Energy Systems

Photovoltaic (PV) cells are electronic components that directly convert solar radiation into electrical energy through the photovoltaic effect. This effect is characterized by the generation of a potential difference between two electrodes when exposed to light. Solar PV cells typically consist of a p-n junction formed from semiconductor materials.

To create an efficient PV cell, several specific requirements must be met, including:

1. Absorption Feature: The material should have a strong ability to absorb sunlight.
2. Window Feature: Materials used as windows must transmit light to the semiconductor and create a structural electric field.
3. Non-Reflective Surface Feature: Materials intended for anti-reflection coatings should minimize light reflection.
4. Contact Feature: The contact material should efficiently collect the current generated by light absorption.

Among these criteria, the absorption feature is of utmost importance. While any semiconductor can potentially serve as an absorbing material for solar PV cells, certain semiconductors are better suited for this purpose.

These criteria collectively contribute to the efficiency and effectiveness of photovoltaic cells in harnessing solar energy.

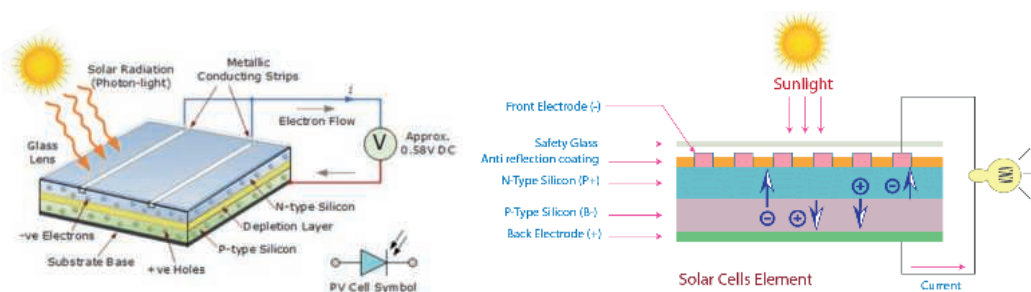

Figure-29. Working Principle of PV Cell and PV Cell Structure

Figure-29 illustrates a solar photovoltaic (PV) cell with a p-n junction configuration. In this diagram, one of the electrical contacts is formed by the bulbars, which also serves the dual purpose of allowing sunlight transmission.

Additionally, an anti-reflection layer is strategically positioned between the finger contacts. This layer plays a crucial role in increasing the amount of transmitted light to the semiconductor component, thereby enhancing the efficiency of the PV cell.

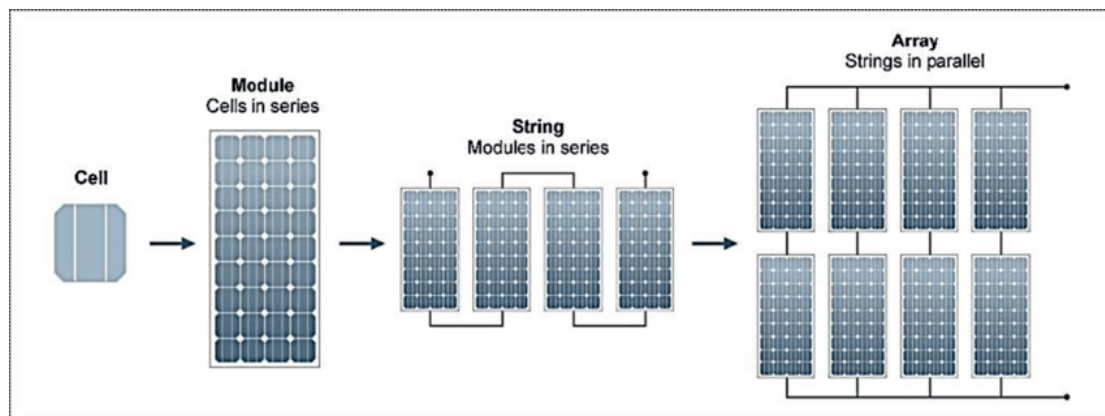

Figure-30. PV Cell, Module and Array Designs

The photovoltaic cells illustrated in Figure-30 are electronic systems designed to directly convert solar radiation into electricity. These cells are distinguished by their lack of moving mechanical components, ease of maintenance, and long lifespan. They are constructed using semiconductor materials, which facilitate the transformation of solar energy into electrical energy.

The operation of a photovoltaic (PV) cell is akin to that of a semiconductor diode, where sunlight energy triggers a photoelectric reaction that results in the generation of electric current. The efficiency of this conversion process typically ranges between 5% and 20%, depending on the specific PV cell structure.

PV cells are commonly found in square, rectangular, or circular shapes, with areas typically falling within the range of 60-160 cm² and an average of around 100 cm². They possess a thickness ranging from 0.2 to 0.4 mm. To enhance the power output, multiple PV cells are often connected in series or parallel configurations and mounted on a surface. This assembly, as depicted in Figure-30, is known as a PV module. Depending on the desired power requirements, PV modules shown in Figure-30 can be connected to each other in either series or parallel fashion, giving rise to PV arrays with capacities ranging from a few watts to several megawatts.

4. Applications of Photovoltaic Training Kit

4.1 Experiment-1 Measurement of Photovoltaic Panel Open Circuit Voltage

Modules required for the experiment;

- Light Angle Adjustable Solar Panel,
- Monophase Switching Module,
- Energy Distribution Module,
- PC Interface Module,
- Light Source Control Module,
- AC/DC Measurement Module,

Experiment Connection;

1. Begin by connecting the energy input to the Energy Distribution Module using a Banana Jack cables for safety reasons.
2. Subsequently, connect the Energy Distribution Module to the other modules using Banana Jack cables.
3. Connect the power input for the Light Source Control module and the lamps of the PV panel to the industrial socket located on the module using Banana Jack cables.
4. To view the measurement values, establish the power connections of the AC/DC Measurement Module and set up the experiment by directly linking the Voltmeter on the module to the solar panel.
5. If you would like to view the measured data and control your light source via computer, make the power connection of the PC Interface Module and connect the AC/DC Measurement Module and Light Source Control Module to the PC Interface Module with CAT6 cable.

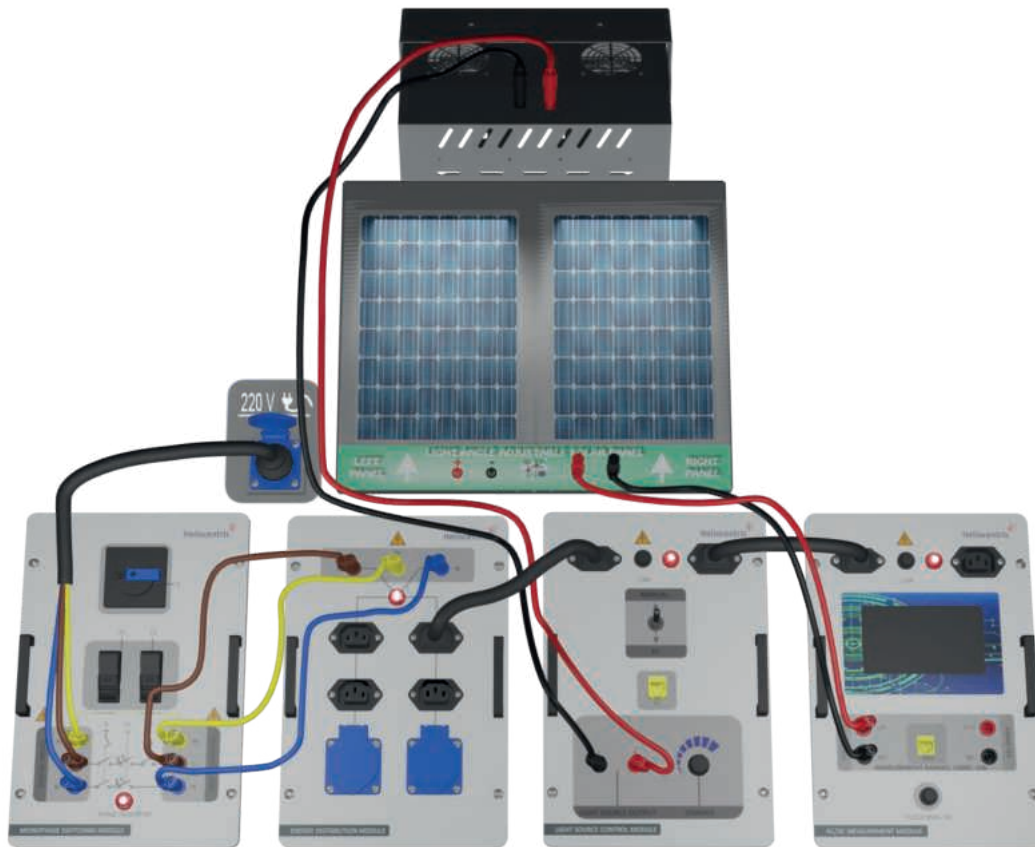

Figure-31. Installation Image of PV Panel Open Circuit Voltage Measurement Experiment

Stages of the Experiment;

1. Locate the open circuit voltage (VOC) provided by the manufacturer for the photovoltaic panels used in the set. You can find this information on a label located on the bottom of the panel. Please note that these values are obtained through testing under 1000W/m² outdoor sun conditions. However, during training, a halogen lamp is used, resulting in an average light power of only 100W/m². Record the VOC value as provided on the label in Table-28.
2. Set up the connections as specified in Figure-31. Ensure a consistent level of light in the laboratory to create an average scenario. Any changes to the positions of the lamps or curtains may affect the experimental outcomes.

- Adjust the angle of incidence of light on the photovoltaic panel to 90° (summer season) and make sure the panel's surface is parallel to the ground. To achieve this, make the necessary adjustments by releasing the pins on the module and placing them in their correct positions.

Open Circuit Experiment	V_{oc} (Label Value)	V_{oc} (Measured Value)	Light Intensity (lux)
PV Panel 1	23,80V	20,55V	9000
PV Panel 2	23,80V	20,45V	10000

Table-28

Research Questions about the Experiment;

- Please explain the reasons for the discrepancy between the V_{oc} value measured in the laboratory and the labelled value.
- Explain the term solar energy.
- Explain the importance of photovoltaic panels by explaining the greenhouse effect.
- Explain the cellular structure of a solar panel by providing a diagram.
- Explain the types and properties of photovoltaic panels.
- Draw the circuit equivalent of the photovoltaic cell and provide a mathematical model explanation.
- Explain how the connection of solar panels in series or parallel affects the V_{oc} value.

Answers to the Research Questions;

1. The values provided on the label are typically obtained from tests performed under outdoor conditions with a light intensity of 1000 W/m^2 . However, the halogen lamps used in the laboratory emit a lower light intensity (100 W/m^2) compared to sunlight, which results in a lower measured VOC value.
2. Solar energy is a type of energy that converts sunlight into electricity or heat. Photovoltaic cells convert this energy directly into electrical energy through the photovoltaic effect.
3. The greenhouse effect is the phenomenon where gases in the atmosphere trap sunlight, warming the planet's surface. Burning fossil fuels contributes to this effect, impacting the climate negatively. Photovoltaic panels produce clean energy and reduce greenhouse gas emissions, making them crucial for environmentally-friendly energy production.
4. A solar panel consists of numerous solar cells made from semiconductor materials. Each cell contains a p-n junction formed between n-type and p-type semiconductor layers.

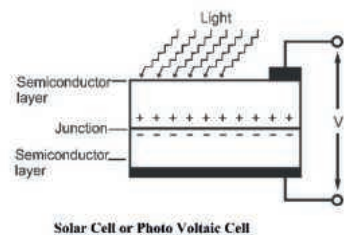

5. Photovoltaic panels are mainly classified into monocrystalline, polycrystalline, and thin-film technologies. Monocrystalline panels are highly efficient, polycrystalline panels are more cost-effective, and thin-film panels are flexible and used in specific applications.
6. A photovoltaic cell is typically represented by a current source, a diode, and a parallel resistor. The current generated by the cell is proportional to the light intensity. The diode represents the p-n junction, and the equivalent circuit also accounts for electrical losses.

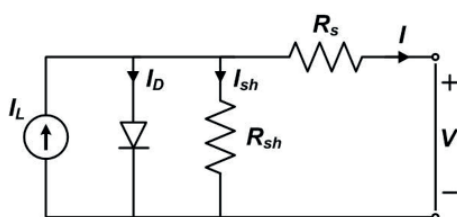

$$I = I_L - I_D - I_{sh}$$

7. When solar panels are connected in series, the V_{OC} values add up. In parallel connections, the V_{OC} value remains the same, but the current increases.

4.2 Experiment-2 Measurement of Photovoltaic Panel Short Circuit Current

Modules required for the experiment;

- Light Angle Adjustable Solar Panel,
- Monophase Switching Module,
- Energy Distribution Module,
- PC Interface Module, (Optional)
- Light Source Control Module,
- AC/DC Measurement Module,

Experiment Connection;

1. Start by connecting the energy input to the Energy Distribution Module using a Banana Jack cables for safety reasons.
2. Subsequently, connect the Energy Distribution Module using Banana Jack cables.
3. Next, connect the power input for the Light Source Control module and the lamps of the PV panel to the industrial socket located on the module with the Banana Jack cables.
4. To measure the electrical parameters, establish the power connections of the AC/DC Measurement Module and connect it to the solar panel. Use appropriate settings to measure current and voltage.
5. If you would like to view the measured data and control your light source via computer, make the power connection of the PC Interface Module and connect the AC/DC Measurement Module and Light Source Control Module to the PC Interface Module with CAT6 cable.

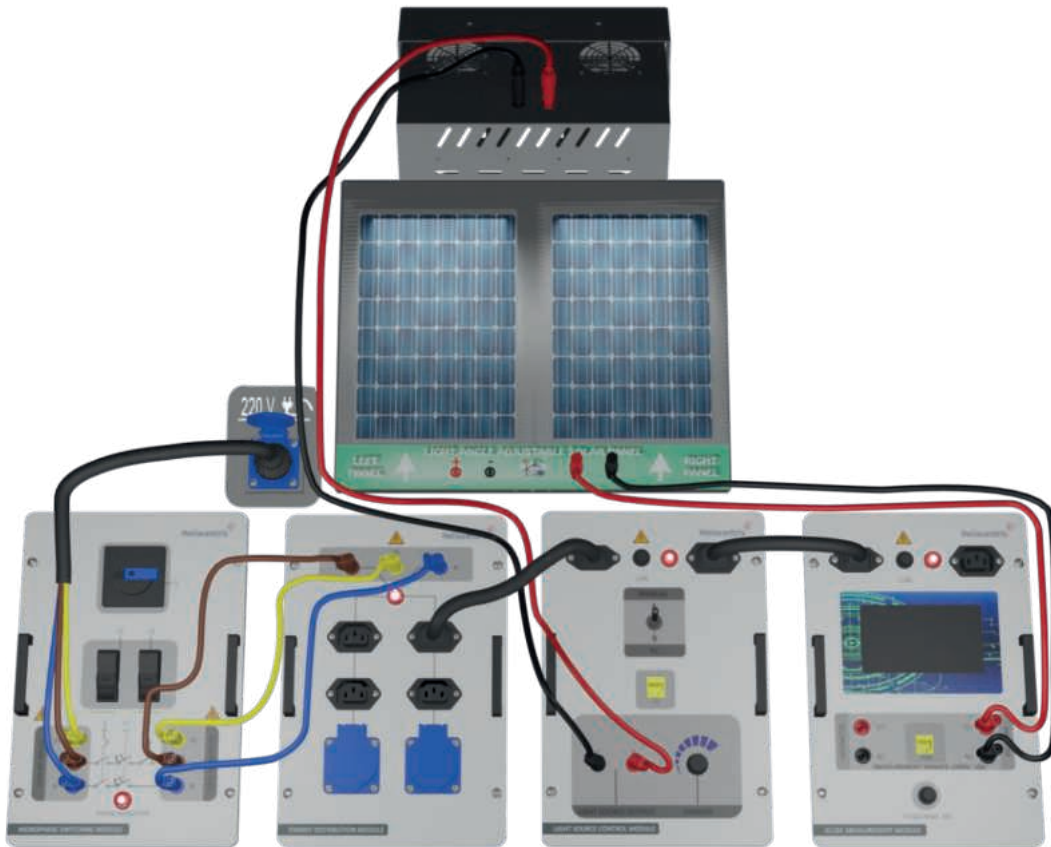

Figure-32. Installation Image of PV Panel Open Circuit Voltage Measurement Experiment

Stages of the Experiment;

1. The manufacturer is provided the open circuit voltage for the photovoltaic panels used in the set on a label located on the bottom of the panel. These values are obtained through testing under $1000\text{W}/\text{m}^2$ outdoor sun conditions. During training, a halogen lamp is used resulting in a average light power of only $100\text{W}/\text{m}^2$. Please record the open circuit voltage value (I_{sc}) as provided on the label in Table-29.
2. Set up the connection as specified in Figure-32. Ensure a constant level of light in the laboratory by creating an average scenario. Any alterations to the positions of the lamps or curtains will have an impact on the experimental outcomes.

3. Align the angle of incidence of light to the photovoltaic panel to 90° (summer season) and the panel surface to be parallel to the ground. To achieve this, make the necessary adjustments by pulling the pins on the module and placing them in their correct positions.
4. Position the digital lux meter at the center of the panel. Adjust the Light Source Control Module's DIMMER potentiometer to its maximum position to set sunlight's maximum brightness. In this instance, determine the highest value on the lux meter by adjusting the light source angle with precision and record the value in Table-29. (Since the distance between the sun and the earth is much greater than the distance between the trainer set and the panel, applying the light source to the panel at an angle less than 90 degrees may cause a higher light intensity than 90 degrees.)
5. Take the lux meter reading from its position and read the value indicated on the Ammeter displayed by the AC/DC Measurement Module. Record the obtained value in Table-29 accordingly. This value denotes the ISC value measured.

Short Circuit Experiment	I _{sc} (Label Value)	I _{sc} (Measured Value)	Light Intensity (lux)
PV Panel 1	600mA	68mA	9000
PV Panel 2	600mA	70mA	10000

Table-29

Research Questions about the Experiment;

1. Please explain the reasons for the discrepancy between the I_{sc} value measured in the laboratory and the labelled value.
2. Draw the electromagnetic spectrum and explain the relation between energy and wavelength using the mathematical equation.
3. Explain how the electric current is generated in the photovoltaic panel.
4. Explain how the connection of solar panels in series or parallel affects the I_{sc} value.

Answers to the Research Questions;

1. I_{SC} values are tested under outdoor conditions with a light intensity of 1000 W/m^2 , while the laboratory uses a lower light intensity (100 W/m^2). This results in a lower I_{SC} value measured in the lab.
2. The relationship between energy and wavelength is given by the equation $E=hc/\lambda$, where E is energy, h is Planck's constant, c is the speed of light, and λ is the wavelength.
3. Electric current is generated in a photovoltaic panel when photons from sunlight hit the surface of the panel, causing electrons to move. This process is known as the photovoltaic effect.
4. In a series connection, the I_{SC} value remains unchanged, but when connected in parallel, the I_{SC} values add up.

4.3 Experiment-3 Photovoltaic Panel Current-Voltage Characteristics

Modules required for the experiment;

- Light Angle Adjustable Solar Panel,
- Monophase Switching Module,
- Energy Distribution Module,
- PC Interface Module, (Optional)
- Light Source Control Module (LSC),
- AC/DC Measurement Module (MM),
- Electronic Potentiometer Module (EP),

Experiment Connection;

1. Begin by connecting the energy input to the Energy Distribution Module using a Banana Jack cables for safety reasons.
2. Proceed to connect the Energy Distribution Module using Banana Jack cables.
3. Next, connect the power input for the Light Source Control Module and the lamps of the PV panel to the industrial socket located on the module with the Banana Jack cables.
4. To view the measurement values, establish the power connections of the Digital AC/DC Measurement Module (MM). Then, connect the Voltmeter on the module directly to the Electronic Potentiometer Module (EP).
5. Connect the positive (+) terminal of the PV panel to the positive (+) terminal of the ammeter.
6. Connect the negative (-) terminal of the ammeter to the positive (+) terminal of the Electronic Potentiometer Module (EP module).
7. Finally, connect the negative (-) terminal of the EP module to the negative (-) terminal of the PV panel to complete the installation of the experiment.
8. If you would like to view the measured data and control your light source and potentiometer via computer, make the power connection of the PC Interface Module

and connect the AC/DC Measurement Module and Light Source Control Module to the PC Interface Module with CAT6 cable.

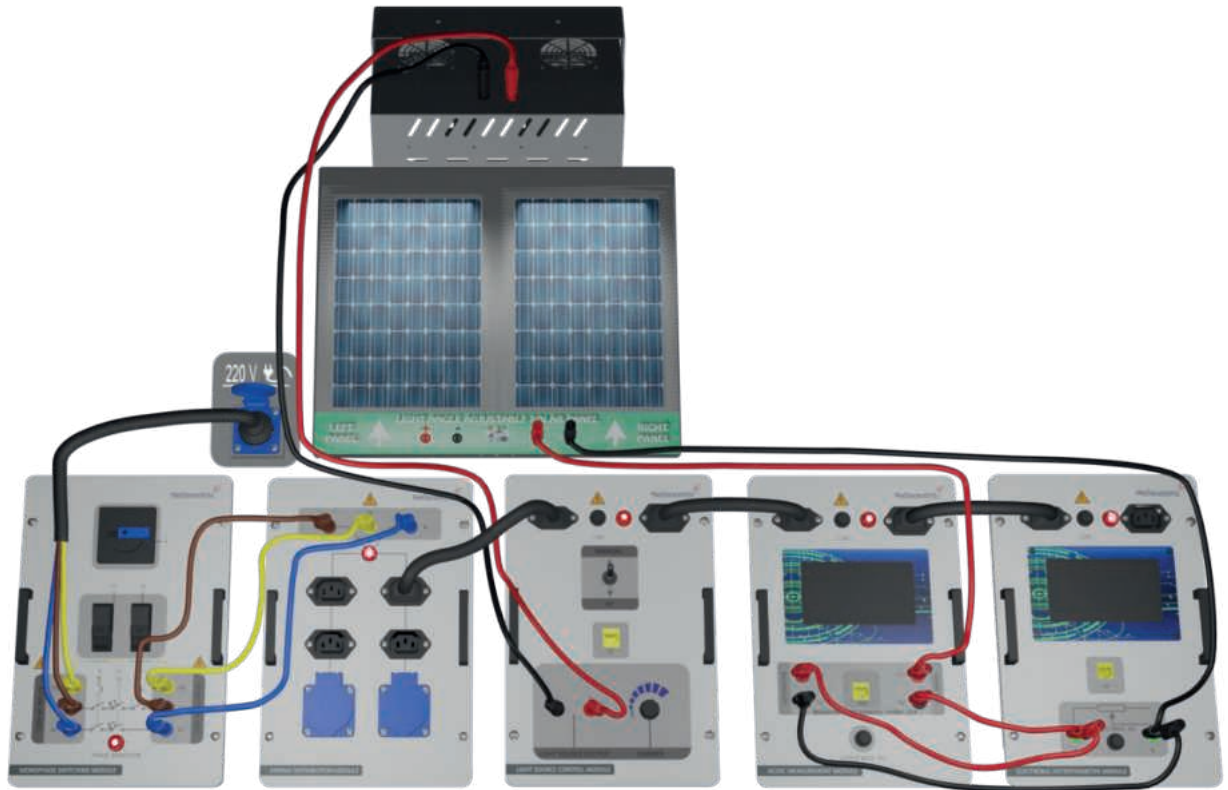

Figure-33. Installation Image of PV Current-Voltage Characteristic Extraction Experiment

Stages of the Experiment;

1. Set up the connection as specified in Figure-33. Ensure a constant level of light in the laboratory by creating an average scenario. Any alterations to the positions of the lamps or curtains will impact the experimental outcomes.
2. Align the angle of incidence of light to the photovoltaic panel to 90° (summer season) and ensure the panel surface is parallel to the ground. Achieve this by making the necessary adjustments with the module's pins, placing them in their correct positions.
3. Position the digital lux meter at the center of the panel. Adjust the Light Source Control Module's DIMMER potentiometer to its maximum position to set sunlight's maximum brightness. In this instance, determine the highest value on the lux meter by precisely adjusting the light source angle. Record this value in Table-30. (Note: Due to the vast distance between the sun and the earth compared to the trainer set and the panel,

applying the light source to the panel at an angle less than 90 degrees may result in a higher light intensity than 90 degrees.)

5. Adjust the Electronic Potentiometer (EP) Module to decrease the load value from 1000 ohms, decreasing it by 100 ohms per step.
6. Record the values displayed on the voltmeter and ammeter of the AC/DC Measurement Module (MM) for each step in Table-30.

R_L (ohm/ Ω)	Voltage (v)	Current (mA)	Power (mW)
1000	20,32	20	406,4
900	20,12	22	442,64
800	20,03	26	520,78
700	19,86	28	556,08
600	19,70	33	650,1
500	19,49	39	760,11
400	18,38	43	790,34
300	16,35	55	899,25
200	11,94	60	716,4
100	6,39	65	415,35
0	0,02	68	1,36

Table-30

7. Plot the current-voltage relationship on the graph provided in Graph-1, utilizing the current and voltage data obtained from Table-30.

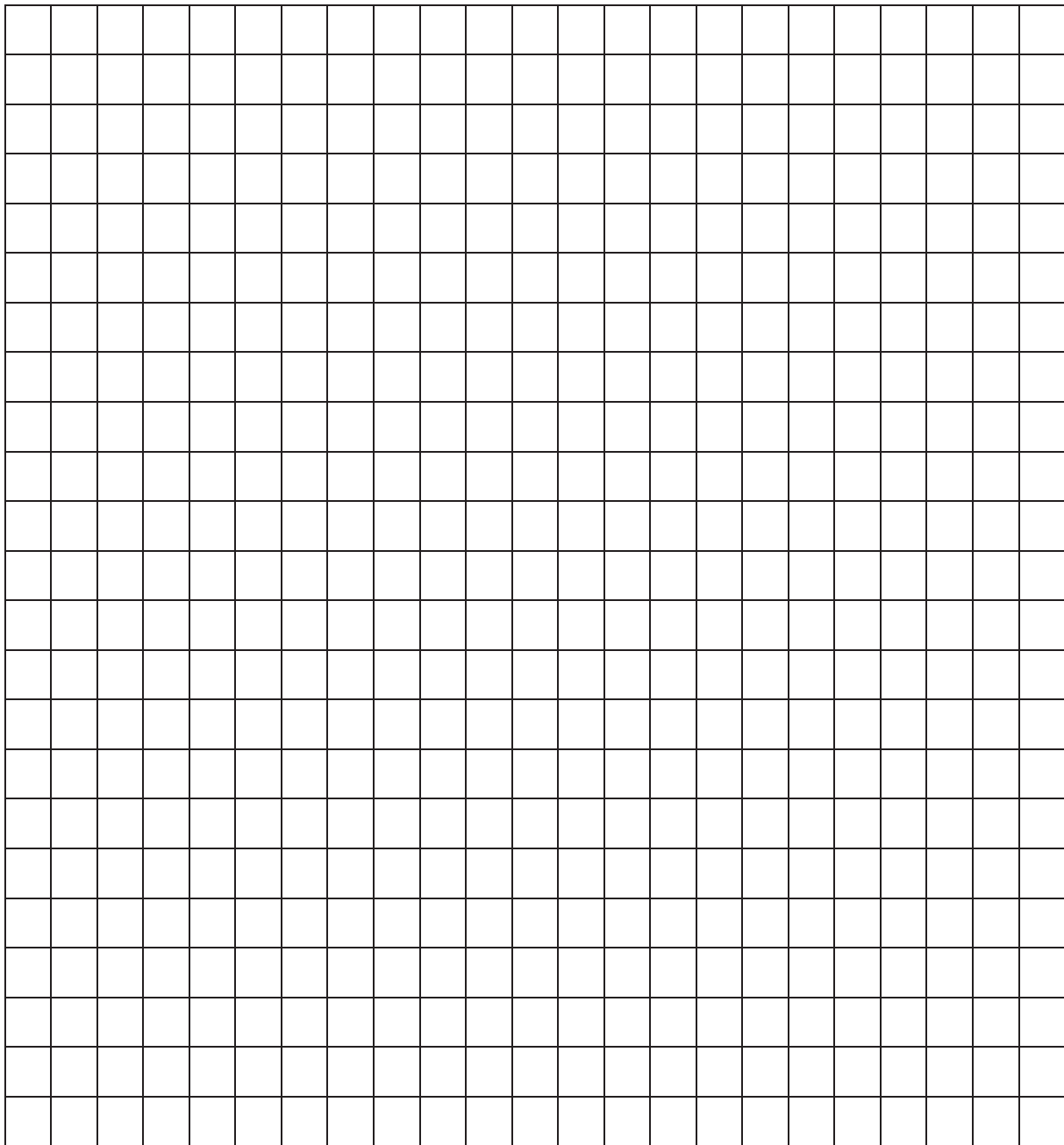

Graph-1

8. Based on the results obtained, plot the power characteristics on the graph provided in Graph-2.

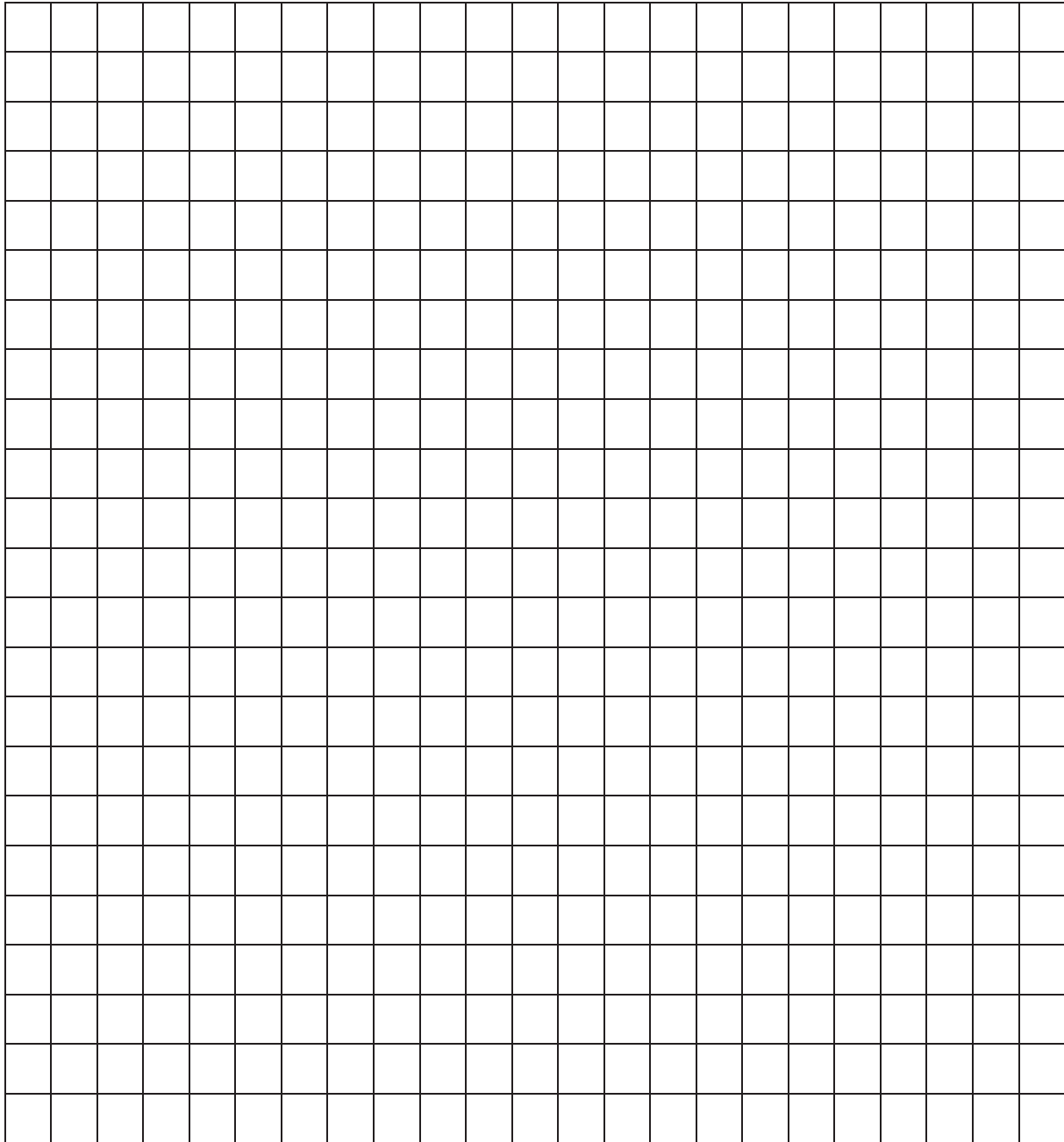

Graph- 2

Research Questions about the Experiment;

1. Discuss the information provided by the IV characteristic of a photovoltaic panel.
2. Identify and explain the point on the graph that corresponds to the maximum power point.
3. Explain what Maximum Power Point Tracking (MPPT) is and its significance in photovoltaic systems.
4. Compare the graph you drew with the provided Graph I

Answers to the Research Questions;

1. The IV characteristic shows the relationship between current and voltage for a photovoltaic panel under varying load conditions. It indicates the maximum power point (MPP), where the panel operates most efficiently. As voltage increases, current decreases, showing the trade-off between the two.
2. The Maximum Power Point (MPP) is the point on the IV curve where the product of current and voltage ($P = I * V$) is at its highest, representing the panel's most efficient operating point.
3. MPPT is a technique used to ensure that a photovoltaic system extracts the maximum possible power from solar panels under varying environmental conditions. It adjusts the operating parameters to match the MPP, optimizing energy output.
4. The graph drawn from the experiment should align with the standard IV characteristic provided in Graph I. Deviations could be due to experimental conditions or light intensity variations.

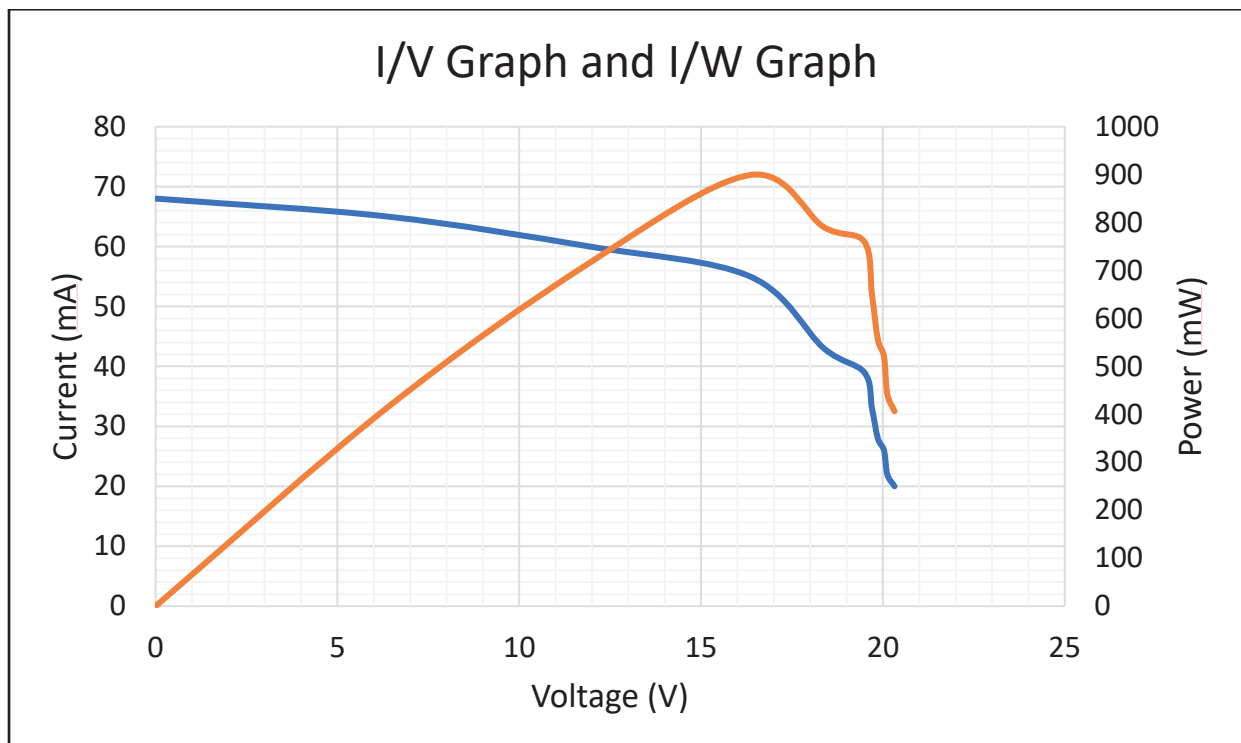

Graph I

4.4 Experiment-4 Examination of the No-Load Outputs of the Photovoltaic Panel Depending on the Sun's In-Day Movement

Modules required for the experiment;

- Light Angle Adjustable Solar Panel,
- Monophase Switching Module,
- Energy Distribution Module,
- PC Interface Module, (Optional)
- Light Source Control Module (LSC),
- AC/DC Measurement Module (MM),

Experiment Connection;

1. Begin by connecting the energy input to the Energy Distribution Module using a Banana Jack cables for safety reasons.
2. Next, connect the Energy Distribution Module using Banana Jack cables.
3. Then, connect the power input for the Light Source Control module and the lamps of the PV panel to the industrial socket located on the module with the Banana Jack cables.
4. To view the measurement values, establish the power connections of the AC/DC Measurement Module and set up the experiment by directly linking the Ammeter and Voltmeter on the module to the solar panel respectively.
5. If you would like to view the measured data and control your light source via computer, make the power connection of the PC Interface Module and connect the MM and LSC Module to the PC Interface Module with CAT6 cable.

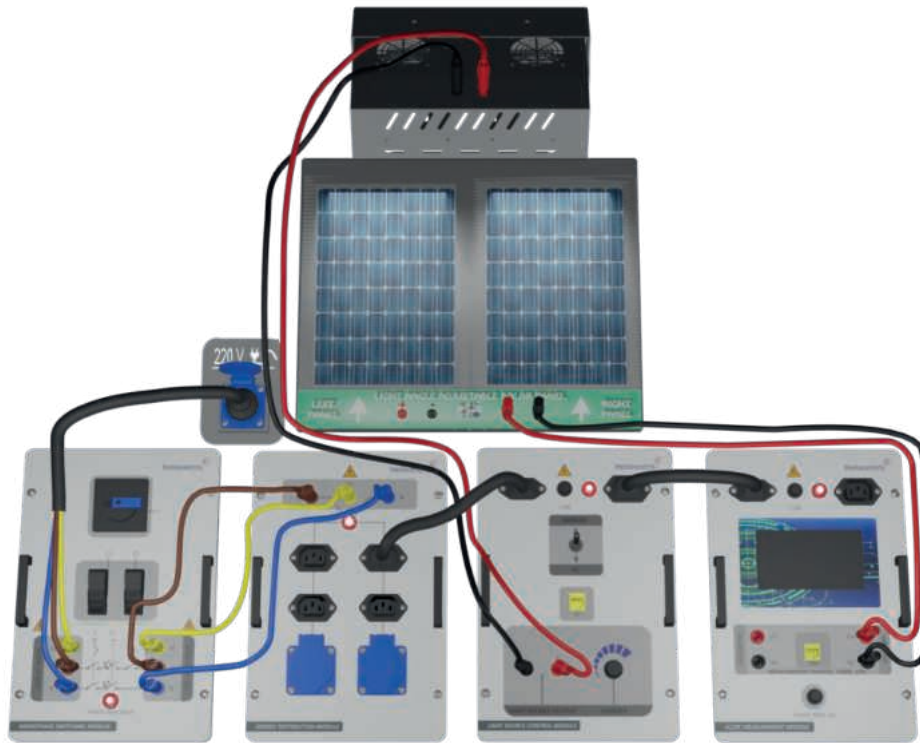

Figure-34. Installation Image of Examination of the No-Load Outputs of the Photovoltaic Panel Depending on the Sun's In-Day Movement (For Current)

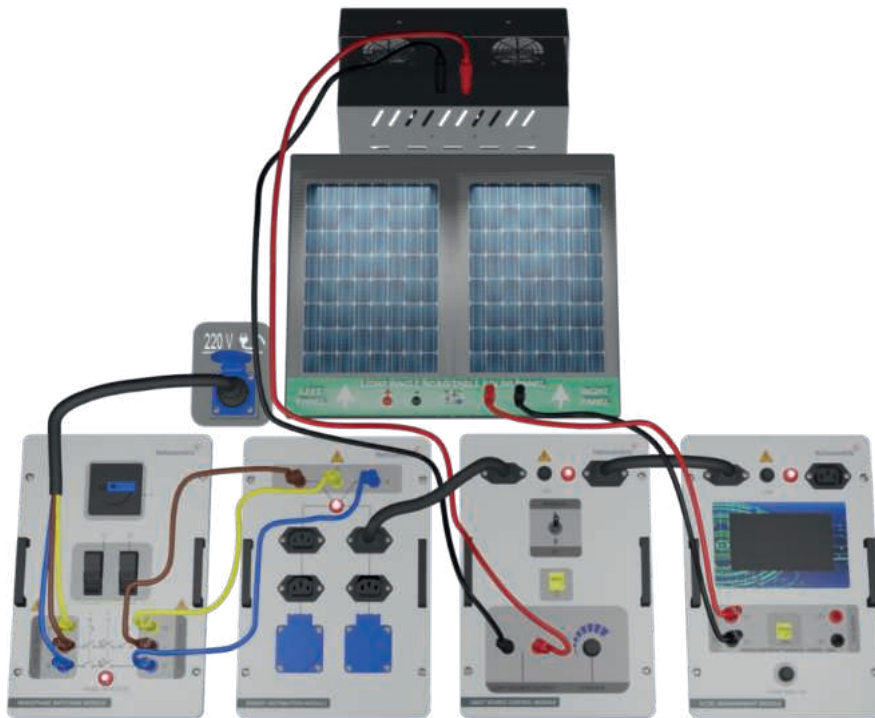

Figure-35. Installation Image of Examination of the No-Load Outputs of the Photovoltaic Panel Depending on the Sun's In-Day Movement (For Voltage)



Figure-36. Photovoltaic Panel Depending on the Sun's In-Day Movement, the panels are moved along this axis

Stages of the Experiment;

1. Set up the connection as specified in Figure-34. Ensure a consistent level of lighting in the laboratory by maintaining an average scenario. Any changes to the positions of the lamps or curtains may affect the experimental results.
2. Set the potentiometer on the LSC module to the highest level.
3. Adjust the incoming light angle to the panel between 0° and 90° using the mitre pins on the module as indicated in the table. Record the corresponding light intensity for each angle measurement in Table-31.
4. Record the voltage and current values that correspond to each angle and light power in Table-31.

Panel Angle According to Light Source	Light Intensity (lux)	Voc	Isc
90°	10000	20,34V	67mA
60°	7350	19,86V	49mA
30°	4230	19,02V	28mA
0°	250	10,82V	1mA

Table-31

Research Questions about the Experiment;

1. How can the highest efficiency of the photovoltaic panel against daylight variations be ensured?
2. Explain the impact of varying daylight on the equivalent circuit and mathematical model of solar cells.
3. Explain the solar tracking system by drawing a block diagram.

Answers to the Research Questions;

1. The highest efficiency of the photovoltaic panel can be ensured by using solar tracking systems. These systems adjust the angle of the panel to always face the sun perpendicularly, maximizing the absorption of sunlight throughout the day.
2. Variations in daylight affect the current and voltage produced by the solar cell. As light intensity decreases, the current decreases, while the voltage remains relatively stable. This results in a decrease in power output. Mathematically, the generated current is directly proportional to the light intensity, while the voltage stays almost constant.
3. A solar tracking system consists of the following components:
 - Sensors (detect the position of the sun),
 - Control system (activates the motors to adjust the panel),
 - Motors (move the panel to maintain optimal orientation),
 - Solar panel (receives the sunlight at the best angle)

4.5 Experiment-5 Examination of the Photovoltaic Panel's Loaded Outputs Depending on the Sun's In-Day Movement

Modules required for the experiment;

- Light Angle Adjustable Solar Panel,
- Monophase Switching Module,
- Energy Distribution Module,
- PC Interface Module, (Optional)
- Light Source Control Module (LSC),
- AC/DC Measurement Module (MM),
- Potentiometer Module,

Experiment Connection;

1. Firstly, connect the energy input to the Energy Distribution Module using a Banana Jack cables for safety reasons.
2. Subsequently, connect the Energy Distribution Module using Banana Jack cables.
3. Next, connect the power input for the Light Source Control module and the lamps of the PV panel to the industrial socket located on the module with the Banana Jack cables.
4. To view the measurement values, make the power connections of the Digital AC/DC Measurement Module and connect the Voltmeter on the module directly to the Potentiometer Module.
5. Connect the positive (+) terminal of the PV panel to the positive (+) terminal of the ammeter, then connect the negative (-) terminal of the ammeter to the positive (+) terminal of the Potentiometer Module.
6. Finally, connect the negative (-) terminal of the Potentiometer Module to the negative (-) terminal of the PV panel and perform the installation of the experiment.
7. If you would like to view the measured data and control your light source via computer, make the power connection of the PC Interface Module and connect the AC/DC Measurement Module and Light Source Control Module to the PC Interface Module with CAT6 cable.

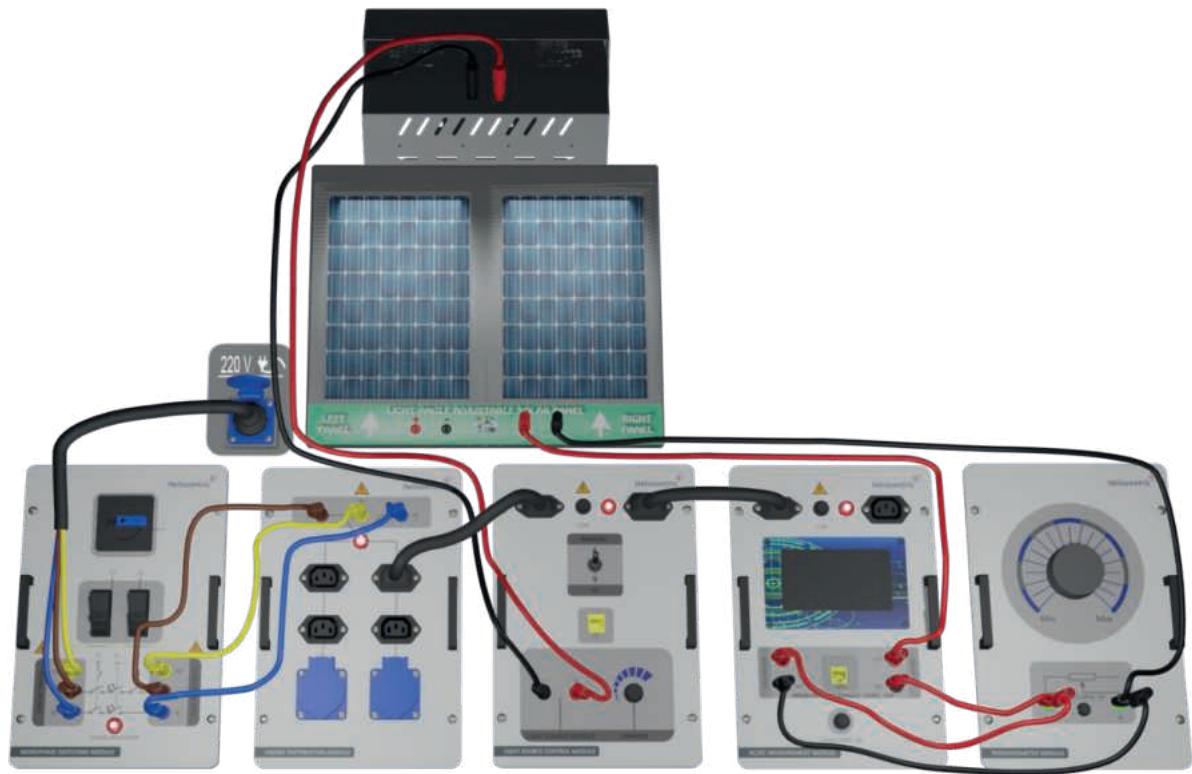

Figure-37. Installation Image of Examination of the Photovoltaic Panel's Loaded Outputs Depending on the Sun's In-Day Movement

Stages of the Experiment;

1. Set up the connection as specified in Figure-37. Ensure a constant level of light in the laboratory by creating an average scenario. Any alterations to the positions of the lamps or curtains will have an impact on the experimental outcomes.
2. Set the Potentiometer Module to a resistance value of 200Ω .
3. Adjust the panel's incoming light angle between 0° and 90° using the mitre pins on the module as specified in the table. Record the corresponding light intensity for each angle measurement in Table-32.
4. Please record the voltage and current values that correspond to each angle and light power within Table-32.

Panel Angle According to Light Source	Light Intensity (lux)	V _{oc}	I _{sc}
90°	10000	20,76V	82mA
60°	7350	20,61V	51mA
30°	4230	19,49V	31mA
0°	250	11,73V	1mA

Table-32

Research Questions about the Experiment;

1. Describe the manner in which the panel output voltage varies in response to the load, based on the intensity of the light.
2. Explain the effect of the battery current determined by the load on the cell equivalent circuit and mathematical model.

Answers to the Research Questions;

1. As the intensity of the light increases, the panel generates higher voltage and current. Under load, higher light intensity leads to increased current flow through the circuit. However, if the load is too high, the panel's voltage can drop as it tries to supply sufficient current.
2. The load determines the current flowing through the panel. As the load decreases (lower resistance), the current increases, affecting the internal losses and reducing the output voltage. In the equivalent circuit model, lower resistance loads result in a larger current, which can increase voltage drop across internal resistances.

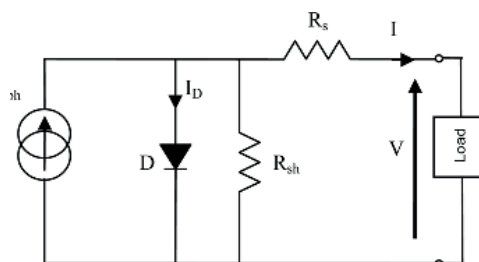

4.6 Experiment-6 Examination of the No-Load Outputs Due to the Season Change of the Photovoltaic Panel

Modules required for the experiment;

- Light Angle Adjustable Solar Panel,
- Monophase Switching Module,
- Energy Distribution Module,
- PC Interface Module, (Optional)
- Light Source Control Module (LSC),
- AC/DC Measurement Module (MM),

Experiment Connection;

1. Begin by connecting the energy input to the Energy Distribution Module using a Banana Jack cables for safety reasons.
2. Subsequently, connect the Energy Distribution Module using Banana Jack cables.
3. Next, connect the power input for the Light Source Control module and the lamps of the PV panel to the industrial socket located on the module using the Banana Jack cables.
4. To view the measurement values, establish the power connections of the AC/DC Measurement Module. Set up the experiment by directly linking the Ammeter and Voltmeter on the module to the solar panel, respectively.
5. If you would like to view the measured data and control your light source via computer, make the power connection of the PC Interface Module and connect the MM and LSC Module to the PC Interface Module with CAT6 cable.

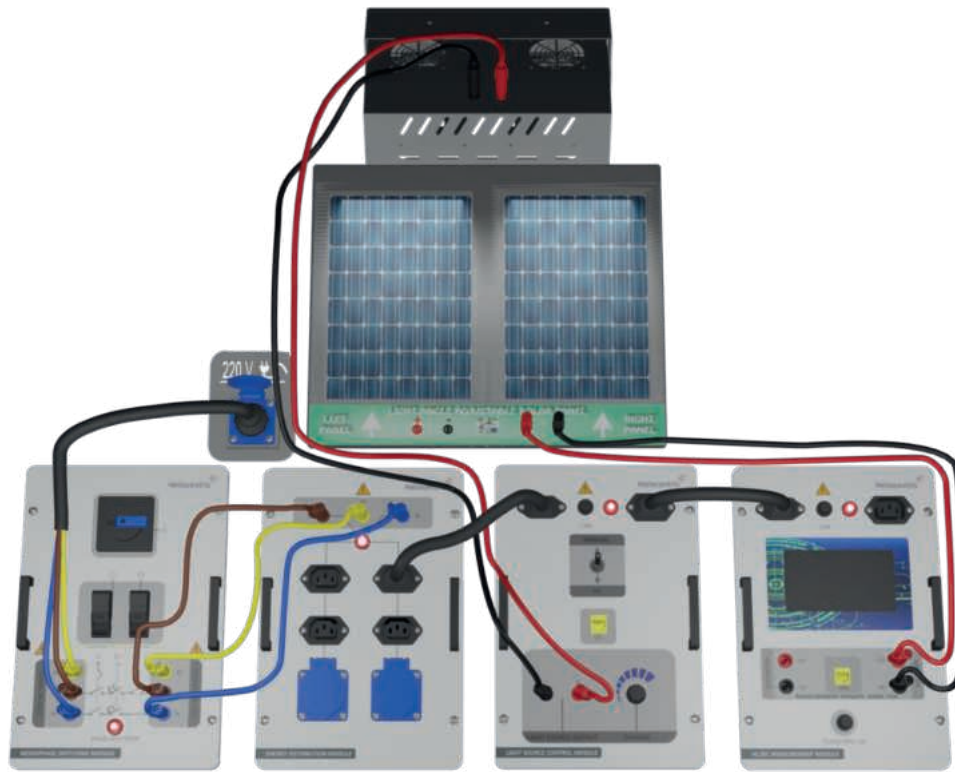

Figure-38. Installation Image of Examination of the No-Load Output Voltage Due to the Season Change of the Photovoltaic Panel (For Current)

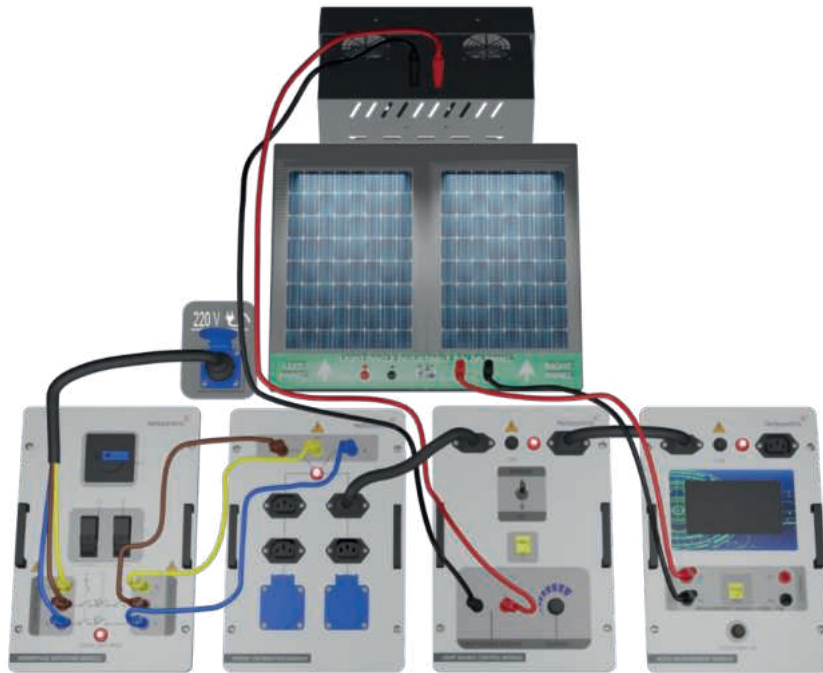

Figure-39. Installation Image of Examination of the No-Load Output Voltage Due to the Season Change of the Photovoltaic Panel (For Voltage)



Figure-40. Due to the Season Change of the Photovoltaic Panel, the panels are moved along this axis.

Stages of the Experiment;

1. Set up the connection as specified in Figure-38. Ensure a constant level of light in the laboratory by creating an average scenario. Any alterations to the positions of the lamps or curtains will have an impact on the experimental outcomes.
2. Set the potentiometer to the highest level on the LSC module.
3. Adjust the panel's incoming light angle between 30° and 90° using the mitre pins on the module as specified in the table. Record the corresponding light intensity for each angle measurement in Table-33.
4. Please record the voltage and current values that correspond to each angle and light power within Table-33.

Panel Angle According to Light Source	Light Intensity (lux)	Voc	Isc
90° (Summer)	10000	20,34V	67mA
60° (Spring)	7350	19,86V	49mA
30° (Winter)	4230	19,02V	28mA

Table-33

Research Questions about the Experiment;

1. Explain how the efficiency of photovoltaic panels changes with the seasons.
2. Find the daylight map by researching the seasonal solar power in your region.
3. Identify the countries that benefit most from solar energy, examine their seasonal characteristics and compare them with your own.

Answers to the Research Questions;

1. The efficiency of photovoltaic panels varies with the seasons due to changes in the angle of sunlight and the length of daylight. During summer, the sun's rays are more direct, resulting in higher energy production. In winter, the sun is lower in the sky, and shorter daylight hours reduce the overall efficiency of the panels.
2. To answer this question, consult local meteorological or renewable energy databases to find a daylight map. These maps show the amount of sunlight available during different seasons, helping optimize the placement and orientation of solar panels.
3. Countries like Germany, China, the United States, India, and Japan benefit greatly from solar energy due to their high solar power potential. These countries invest in large solar energy projects and have varying seasonal characteristics. Compared to

4.7 Experiment-7 Examination of the Loaded Outputs Due to the Season Change of the Photovoltaic Panel

Modules required for the experiment;

- Light Angle Adjustable Solar Panel,
- Monophase Switching Module,
- Energy Distribution Module,
- PC Interface Module, (Optional)
- Light Source Control Module (LSC),
- AC/DC Measurement Module (MM),
- Potentiometer Module,

Experiment Connection;

1. Firstly, connect the energy input to the Energy Distribution Module using a Banana Jack cables for safety reasons.
2. Subsequently, connect the Energy Distribution Module using Banana Jack cables.
3. Next, connect the power input for the Light Source Control module and the lamps of the PV panel to the industrial socket located on the module with the Banana Jack cables.
4. To see the measurement values, make the power connections of the Digital AC/DC Measurement Module and connect the Voltmeter on the module directly to the Potentiometer Module.
5. Connect the positive (+) terminal of the PV panel to the positive (+) terminal of the ammeter.
6. Then, connect the negative (-) terminal of the ammeter to the positive (+) terminal of the Potentiometer Module.
7. Finally, connect the negative (-) terminal of the Potentiometer Module to the negative (-) terminal of the PV panel and perform the installation of the experiment.
8. If you would like to view the measured data and control your light source via computer, make the power connection of the PC Interface Module and connect the AC/DC

Measurement Module and Light Source Control Module to the PC Interface Module with CAT6 cable.

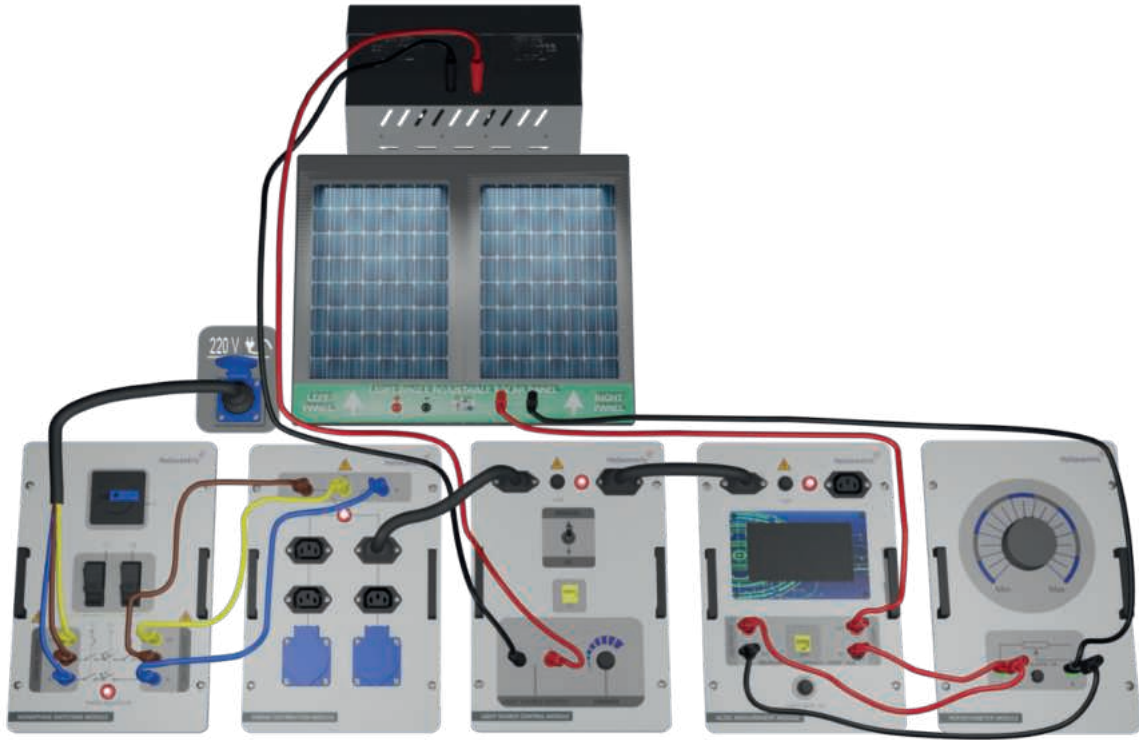

Figure-41. Installation Image of Examination of the Loaded Output Voltage Due to the Season Change of the Photovoltaic Panel

Stages of the Experiment;

1. Set up the connection as specified in Figure-41. Ensure a constant level of light in the laboratory by creating an average scenario. Any alterations to the positions of the lamps or curtains will have an impact on the experimental outcomes.
2. Set the potentiometer to the highest level on the LSC module.
3. Set the Potentiometer Module to a resistance value of 500Ω.
4. Adjust the panel's incoming light angle between 30° and 90° using the mitre pins on the module as specified in the table. Record the corresponding light intensity for each angle measurement in Table-34.
5. Please record the voltage and current values that correspond to each angle and light power within Table-34.
6. The load value should be reduced from 500 ohms to 200 ohms. The subsequent measurements should be repeated and recorded in Table-34.

Panel Angle According to Light Source	Light Intensity (lux)	V (500 Ω)	I (500 Ω)	V (200 Ω)	I (200 Ω)
90° (Summer)	10000	16,21V	34mA	8,49V	44mA
60° (Spring)	8150	14,83V	31mA	6,18V	32mA
30° (Winter)	2530	8,61V	18mA	3,62V	19mA

Table-34

Research Questions about the Experiment;

1. Analyse the effect of a load change on the outputs.
2. Explain how the temperature change will affect the output voltage of the panel.

Answers to the Research Questions;

1. Increasing the load (decreasing resistance) causes more current to flow, but the panel's voltage output will decrease. This can reduce the overall power output if the load exceeds the panel's capacity to generate enough current without significant voltage drops.
2. As temperature increases, the output voltage of the panel decreases. This is because the semiconductor material's bandgap decreases with rising temperature, allowing for easier electron movement but reducing the potential difference. Typically, there is a 0.5% reduction in voltage for every degree Celsius increase in temperature.

4.8 Experiment-8 Examination of the Series Connection of Photovoltaic Panel

Modules required for the experiment;

- Light Angle Adjustable Solar Panel,
- Monophase Switching Module,
- Energy Distribution Module,
- PC Interface Module, (Optional)
- Light Source Control Module (LSC),
- AC/DC Measurement Module (MM),
- Electronic Potentiometer Module (EP),

Experiment Connection;

1. Connect the energy input to the Energy Distribution Module using a Banana Jack cables for safety reasons.
2. Subsequently, connect the Energy Distribution Module using Banana Jack cables.
3. Next, connect the power input for the Light Source Control module and the lamps of the PV panel to the industrial socket located on the module with the Banana Jack cables.
4. To view the measurement values, make the power connections of the Digital AC/DC Measurement Module and connect the "+" terminal of the first PV panel to the "+" terminal of the voltmeter on the module.
5. Next, connect the "-" terminal of the first panel to the "+" terminal of the second PV panel.
6. Finally, connect the "-" terminal of the second panel to the "-" terminal of the voltmeter and complete the series connection.
7. If you would like to view the measured data and control your light source and potentiometer via computer, make the power connection of the PC Interface Module and connect the AC/DC Measurement Module and Light Source Control Module to the PC Interface Module with CAT6 cable.

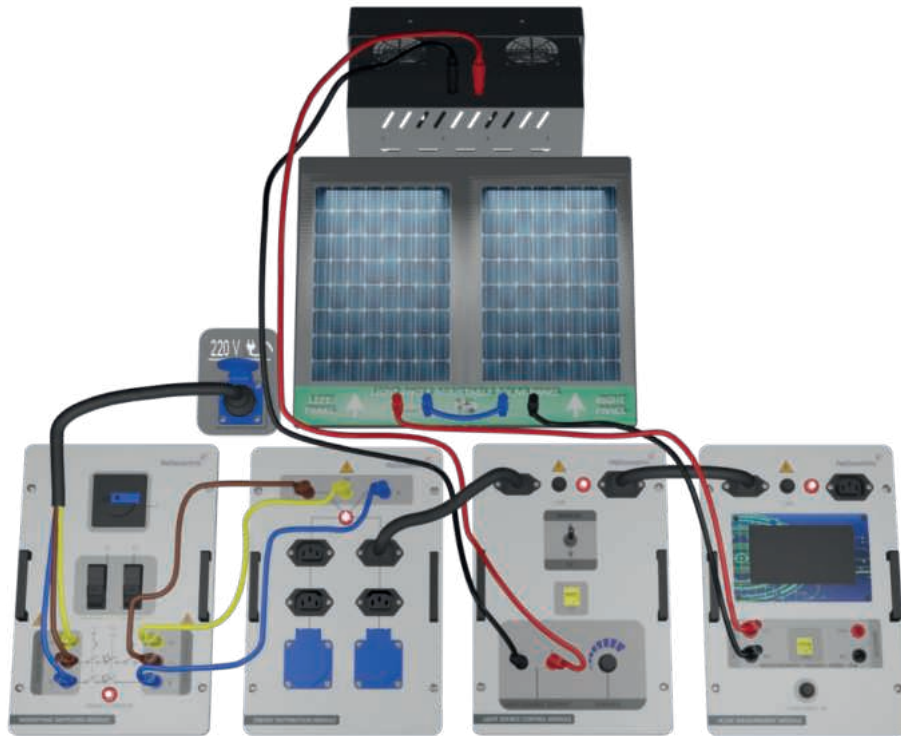

Figure-42. Installation Image of Examination of the Series Connection of Photovoltaic Panel (For Voltage)

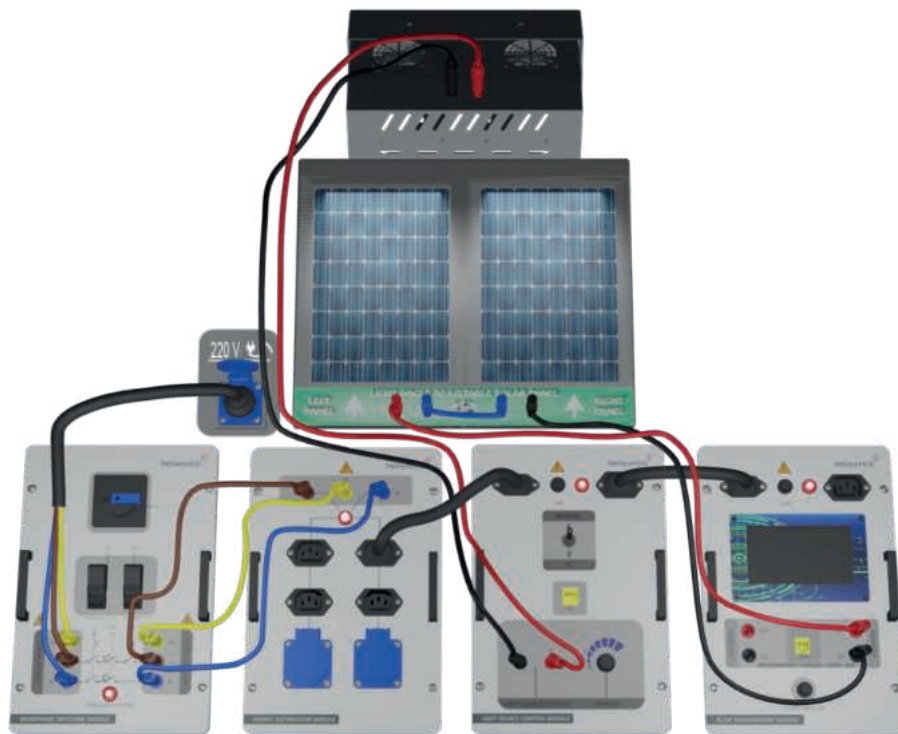

Figure-43. Installation Image of Examination of the Series Connection of Photovoltaic (For Current)

Stages of the Experiment;

1. Set up the connection as specified in Figure-42. Ensure a constant level of light in the laboratory by creating an average scenario. Any alterations to the positions of the lamps or curtains will have an impact on the experimental outcomes.
2. Align the angle of incidence of light to the photovoltaic panel to 90° (summer season) and the panel surface to be parallel to the ground. To achieve this, make the necessary adjustments by pulling the pins on the module and placing them in their correct positions. Set the potentiometer to the highest level on the LSC module.
3. Record the value displayed by the voltmeter in the MM module in Table-35. Remove the Banana Jacks from the voltmeter, connect them to the ammeter, and record the short-circuit current in Table-35.
4. By setting the potentiometer module to 1000Ω , connect it to the series-connected panel output terminals as shown in Figure-44.
5. Measure the output voltage and current by reducing the load by 100Ω . Record the values in Table-36.

V_{oc}	I_{sc}

Table-35

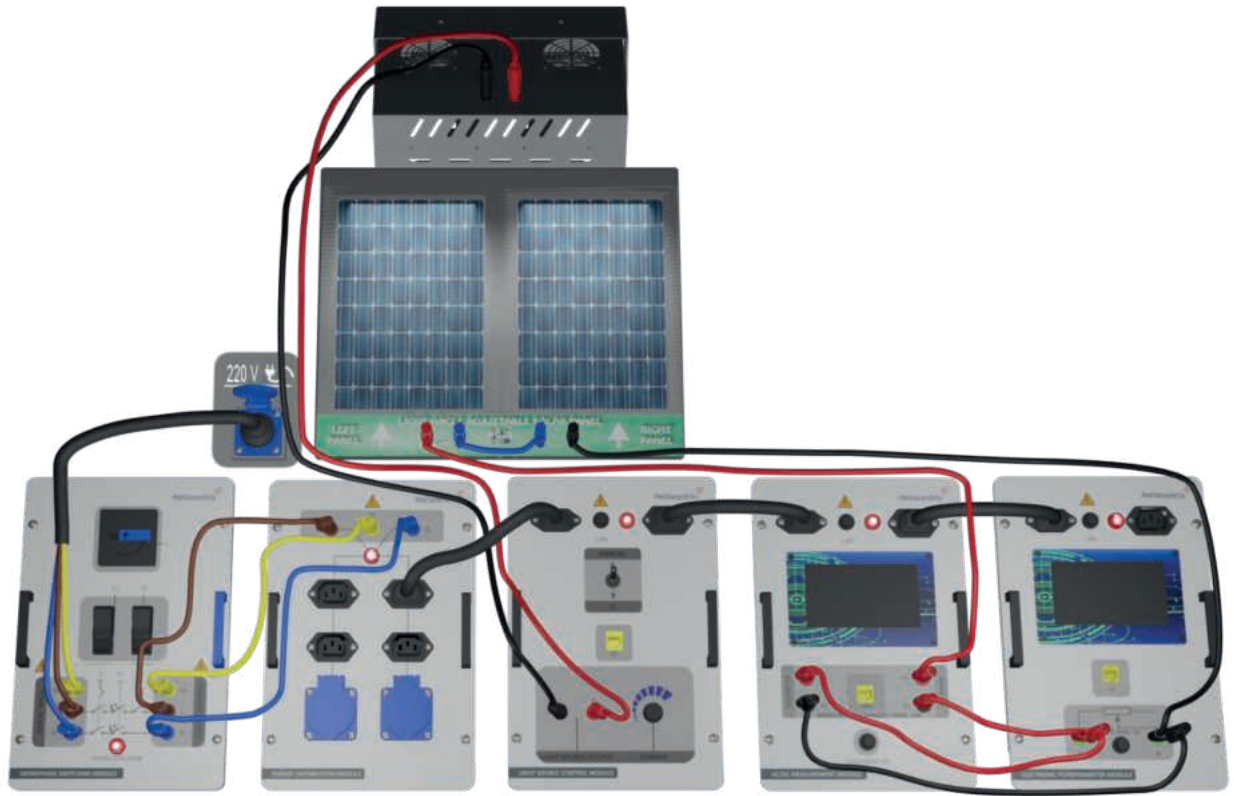

Figure-44. Installation Image of Examination of the Series Connection of Photovoltaic Panel (Loaded)

R_L (Ohm/ Ω)	Voltage (V)	Current (mA)	Power (mW)
1000	36,9	39	1439,1
900	36,27	42	1523,34
800	35,43	46	1629,78
700	33,17	49	1625,33
600	29,37	51	1497,87
500	25,12	52	1306,24
400	20,55	54	1109,7
300	15,93	55	876,15
200	11,16	58	647,28
100	5,82	60	349,2
0	0,0016	61	0,0976

Table-36

6. Explain the effect of series connection of photovoltaic panels on equivalent parallel resistance.

7. Draw the current and voltage curves of the photovoltaic panels on Graph-1 and determine the MPPT point.

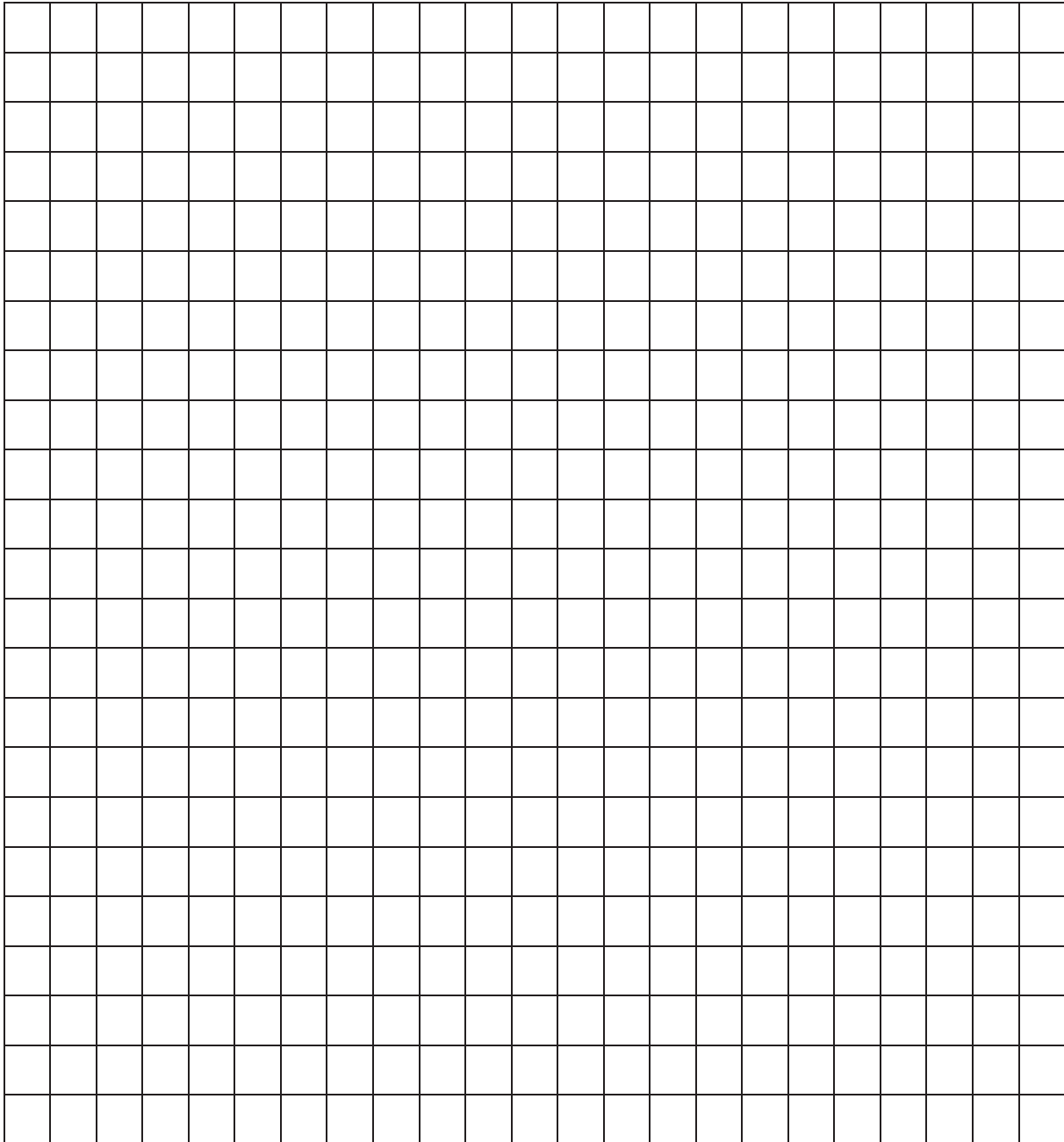

Graph-1

4.9 Experiment-9 Examination of the Parallel Connection of Photovoltaic Panel

Modules required for the experiment;

- Light Angle Adjustable Solar Panel,
- Monophase Switching Module,
- Energy Distribution Module,
- PC Interface Module, (Optional)
- Light Source Control Module (LSC),
- AC/DC Measurement Module (MM),
- Electronic Potentiometer Module (EP),

Experiment Connection;

1. Firstly, connect the energy input to the Energy Distribution Module using a Banana Jack cables for safety reasons.
2. Subsequently, connect the Energy Distribution Module using Banana Jack cables.
3. Next, connect the power input for the Light Source Control module and the lamps of the PV panel to the industrial socket located on the module with the Banana Jack cables.
4. To see the measurement values, make the power connections of the Digital AC/DC Measurement Module.
5. Connect the "+" terminal of the first PV panel to the "+" terminal of the voltmeter, and the "-" terminal of the first PV panel to the "-" terminal of the voltmeter on the module.
6. Next, connect the "+" terminal of the first panel to the "+" terminal of the second PV panel.
7. Finally, connect the "-" terminal of the second panel to the "-" terminal of the first panel to complete the parallel connection.
8. If you would like to view the measured data and control your light source and potentiometer via computer, make the power connection of the PC Interface Module and connect the AC/DC Measurement Module and Light Source Control Module to the PC Interface Module with CAT6 cable.

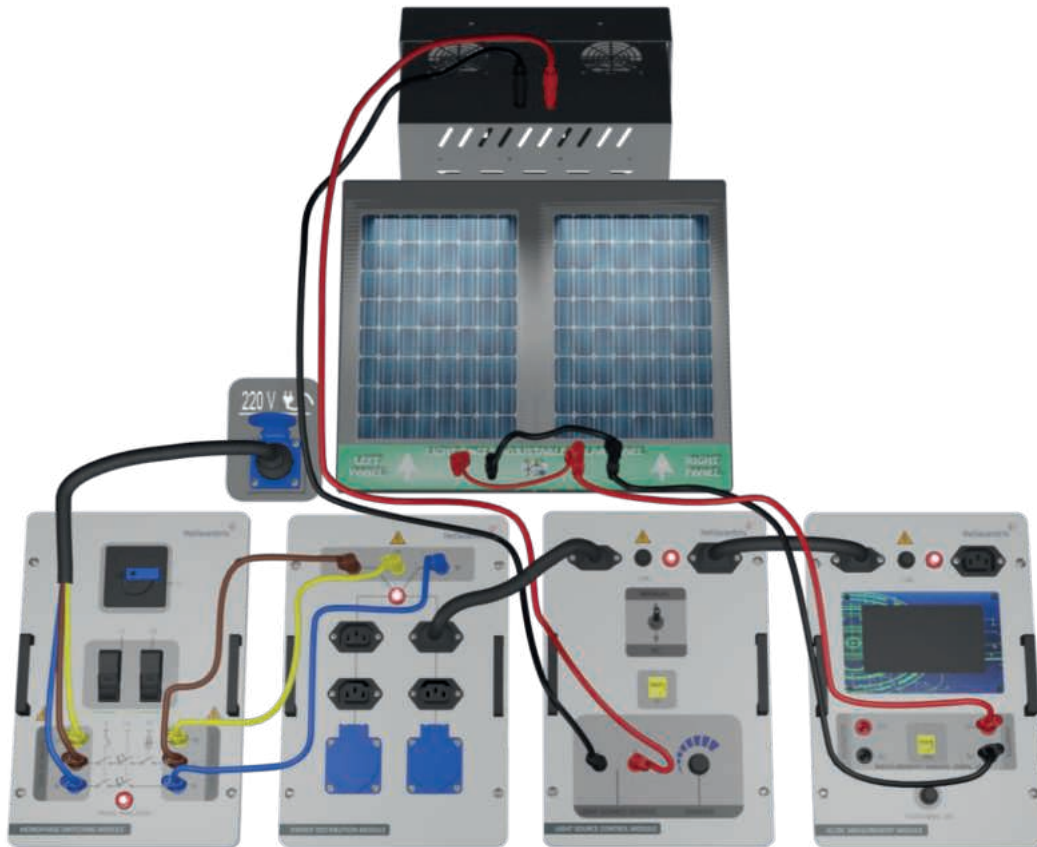

Figure-45. Installation Image of Examination of the Parallel Connection of Photovoltaic Panel

Stages of the Experiment;

1. Set up the connection as specified in Figure-45. Ensure a constant level of light in the laboratory by creating an average scenario. Any alterations to the positions of the lamps or curtains will have an impact on the experimental outcomes.
2. Align the angle of incidence of light to the photovoltaic panel to 90° (summer season) and the panel surface to be parallel to the ground. To achieve this, make the necessary adjustments by pulling the pins on the module and placing them in their correct positions. Set the potentiometer to the highest level on the LSC module.
3. Record the value displayed by the voltmeter in the DM module in Table-37. Remove the Banana Jacks from the voltmeter, connect to the ammeter and record the short-circuit current in Table-37.

V_{oc}	I_{sc}

Table-37

- By setting the potentiometer module to 1000Ω , connect to the series connected panel output terminals Figure-46 as shown in.
- Measure the output voltage and current by reducing the load by 100Ω . Record the values in Table-38.

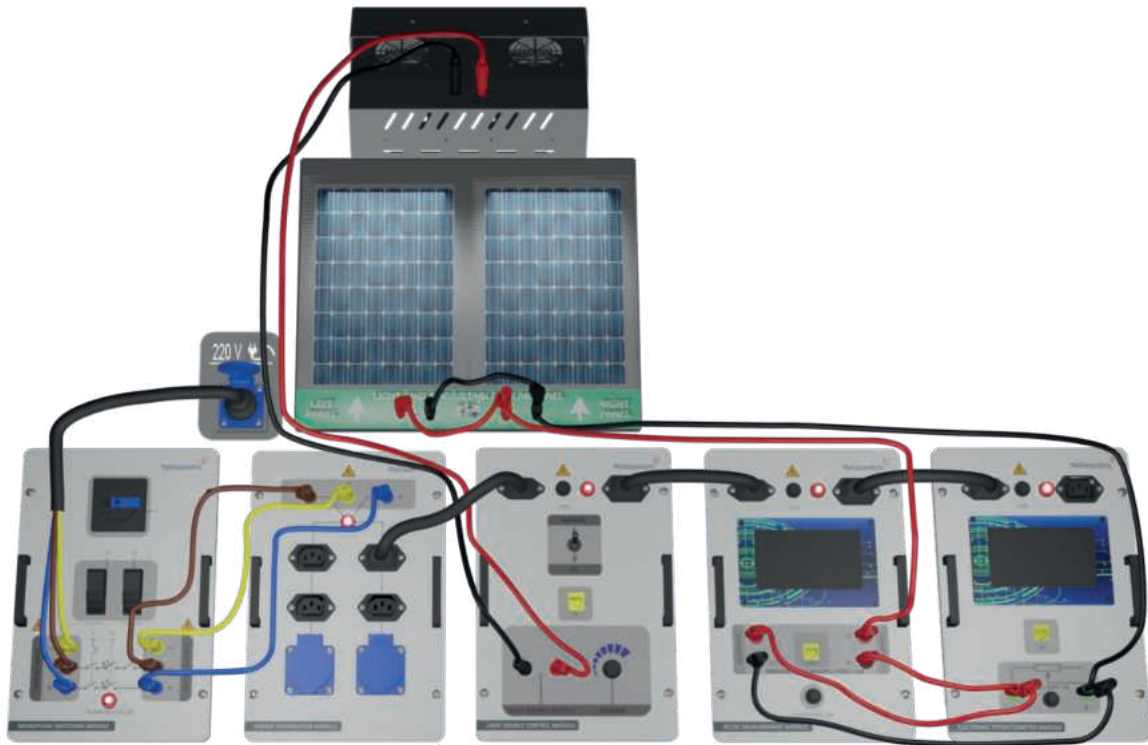
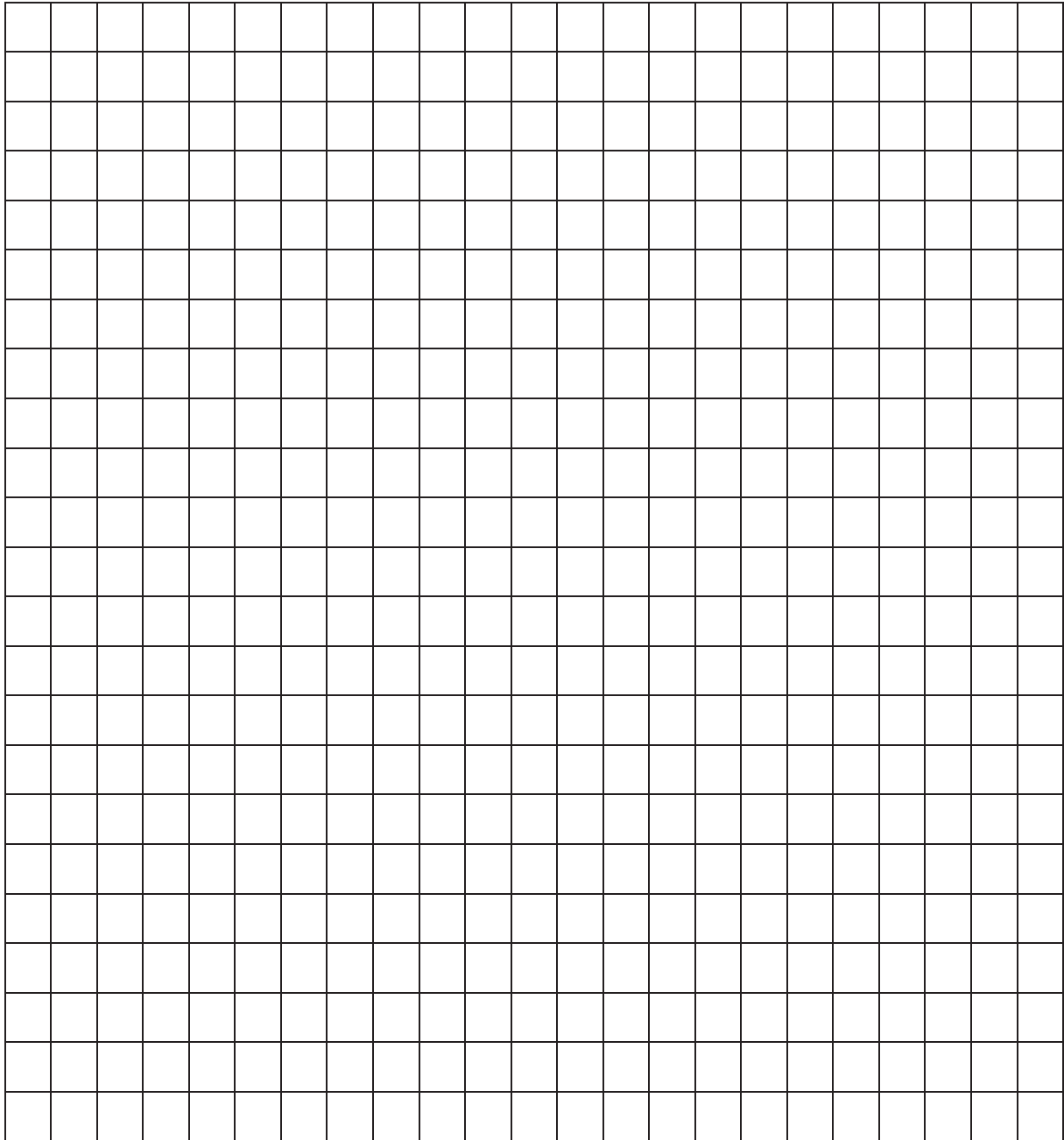

Figure-46. Installation Image of Examination of the Parallel Connection of Photovoltaic Panel (Loaded)

R_L (Ω)	Voltage (V)	Current (mA)	Power (mW)
1000	20	21	420
900	19,96	23	459,08
800	19,89	26	517,14
700	19,8	29	574,2
600	19,69	34	669,46
500	19,62	41	804,42
400	19,26	50	963
300	18,73	65	1217,45
200	17,41	90	1566,9
100	12,04	122	1468,88
0	0,03	132	3,96

Table-38

6. Explain the effect of connecting photovoltaic panels in parallel on the equivalent parallel resistance.
7. Draw the current and voltage curve of the photovoltaic panels on Graph-1 and determine the MPPT point.



Graph-1

4.10 Experiment-10 Examination of Shadow Effect in Photovoltaic Panel

Modules required for the experiment;

- Light Angle Adjustable Solar Panel,
- Monophase Switching Module,
- Energy Distribution Module,
- PC Interface Module, (Optional)
- Light Source Control Module (LSC),
- AC/DC Measurement Module (MM),
- Electronic Potentiometer Module (EP),

Experiment Connection;

1. Begin by connecting the energy input to the Energy Distribution Module using a Banana Jack cables for safety reasons.
2. Subsequently, connect the Energy Distribution Module using Banana Jack cables.
3. Next, connect the power input for the Light Source Control module and the lamps of the PV panel to the industrial socket located on the module with the Banana Jack cables.
4. To view the measurement values, make the power connections of the Digital AC/DC Measurement Module. Connect the "+" terminal of the first PV panel to the "+" terminal of the voltmeter on the module. Then, connect the "-" terminal of the first panel to the "+" terminal of the second PV panel. Finally, connect the "-" terminal of the second panel to the "-" terminal of the voltmeter to complete the series connection.
5. If you would like to view the measured data and control your light source and potentiometer via computer, make the power connection of the PC Interface Module and connect the AC/DC Measurement Module and Light Source Control Module to the PC Interface Module with CAT6 cable.

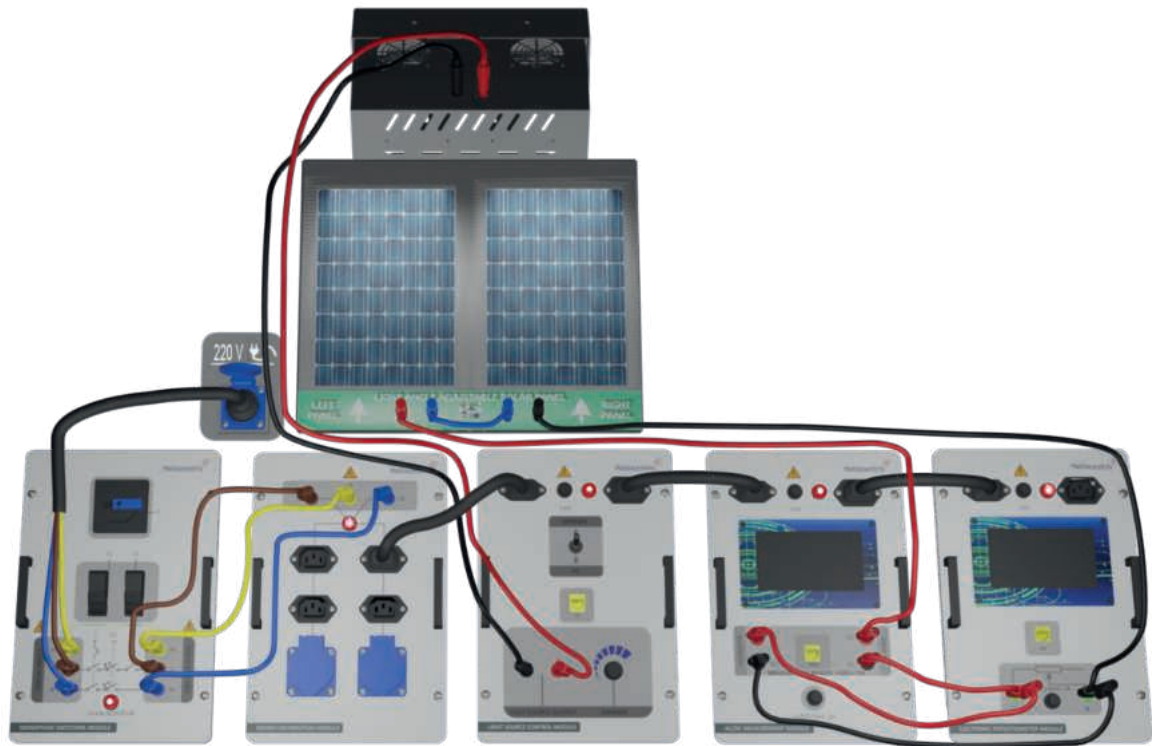

Figure-47. Installation Image of Examination of Shadow Effect in Photovoltaic Panel

Stages of the Experiment;

1. Set up the connection as specified in Figure-47. Ensure a constant level of light in the laboratory by creating an average scenario. Any alterations to the positions of the lamps or curtains will have an impact on the experimental outcomes.
2. Align the angle of incidence of light to the photovoltaic panel to 90° (summer season) and the panel surface to be parallel to the ground. To achieve this, make the necessary adjustments by pulling the pins on the module and placing them in their correct positions. Set the potentiometer to the highest level on the LSC module.
3. By setting the potentiometer module to 1000Ω , connect to the series connected panel output terminals as shown in Figure-47.
4. Cover one side of the PV panel with a paper-like shading device as shown in Figure-48.
5. Measure the output voltage and current by reducing the load by 100Ω . Record the values in Table-39.

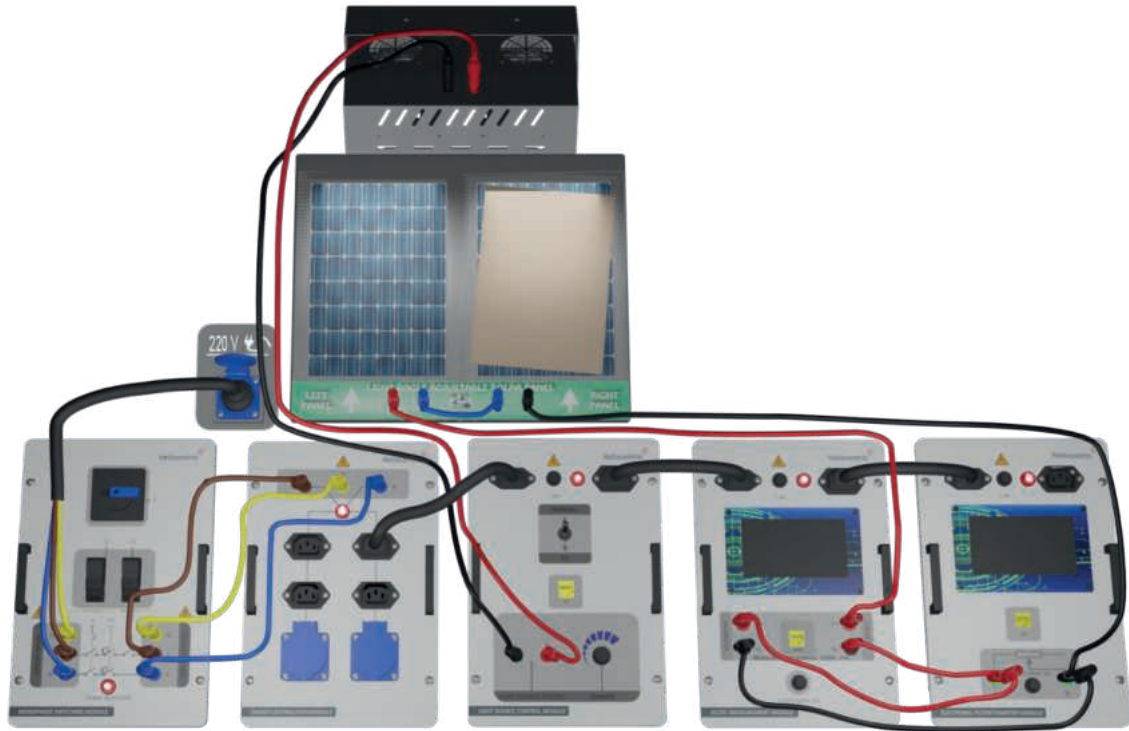

Figure-48. Installation Image of Examination of Shadow Effect in Photovoltaic Panel

- Open the panel that was covered in the previous step, cover the other panel, and record the voltage and current values of the MM module in this state in Table-39.

Series Connection	Left side open - Right side shaded		Left side shaded - Right side open	
	Voltage (V)	Current (mA)	Voltage (V)	Current (mA)
R_L (Ohm/ Ω)				
1000	5,46	5	11,4	11
900	4,29	5	10,34	11
800	4,36	5	9,26	11
700	3,99	5	8,14	11
600	3,16	5	8,13	12
500	2,98	5	5,88	12
400	2,41	5	4,74	12
300	1,83	6	3,58	12
200	1,24	6	2,14	12
100	0,63	6	1,22	12
0	0,002	6	0,004	12

Table-39

7. Explain the shadow effect.
8. Carry out the same experiment by connecting the panels in parallel. Record the measurements in Table-40.
9. Analyse the given graphs.

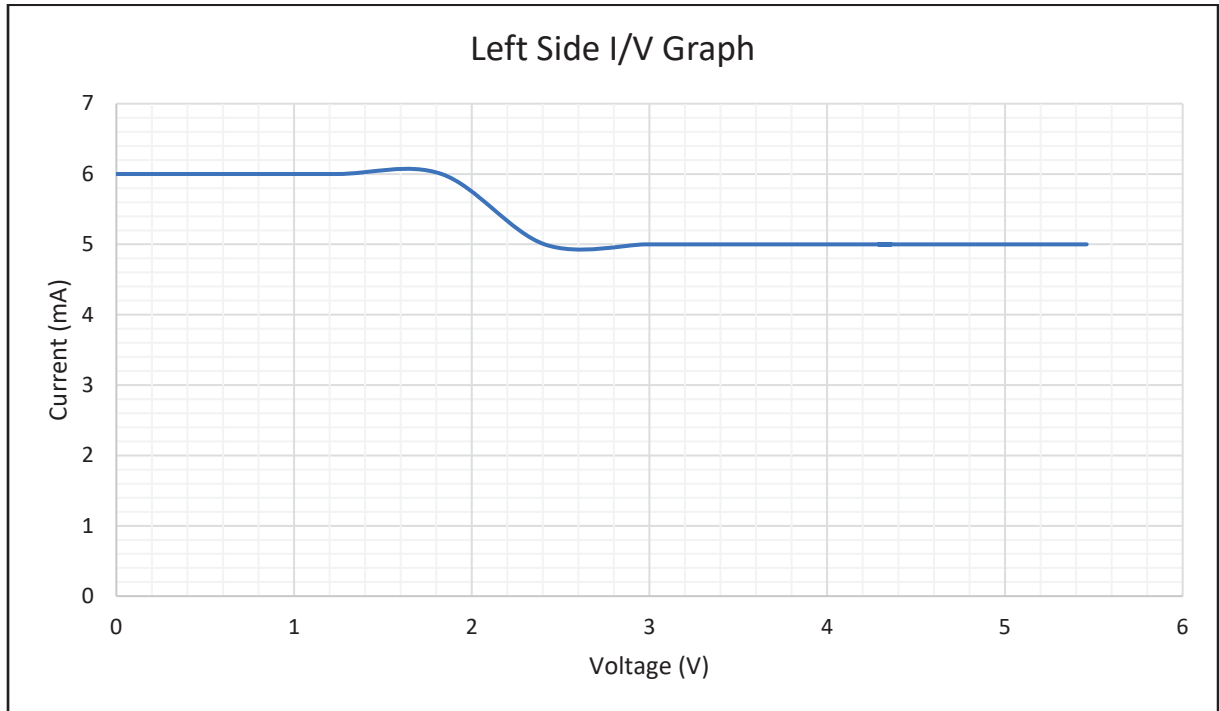

Graph II

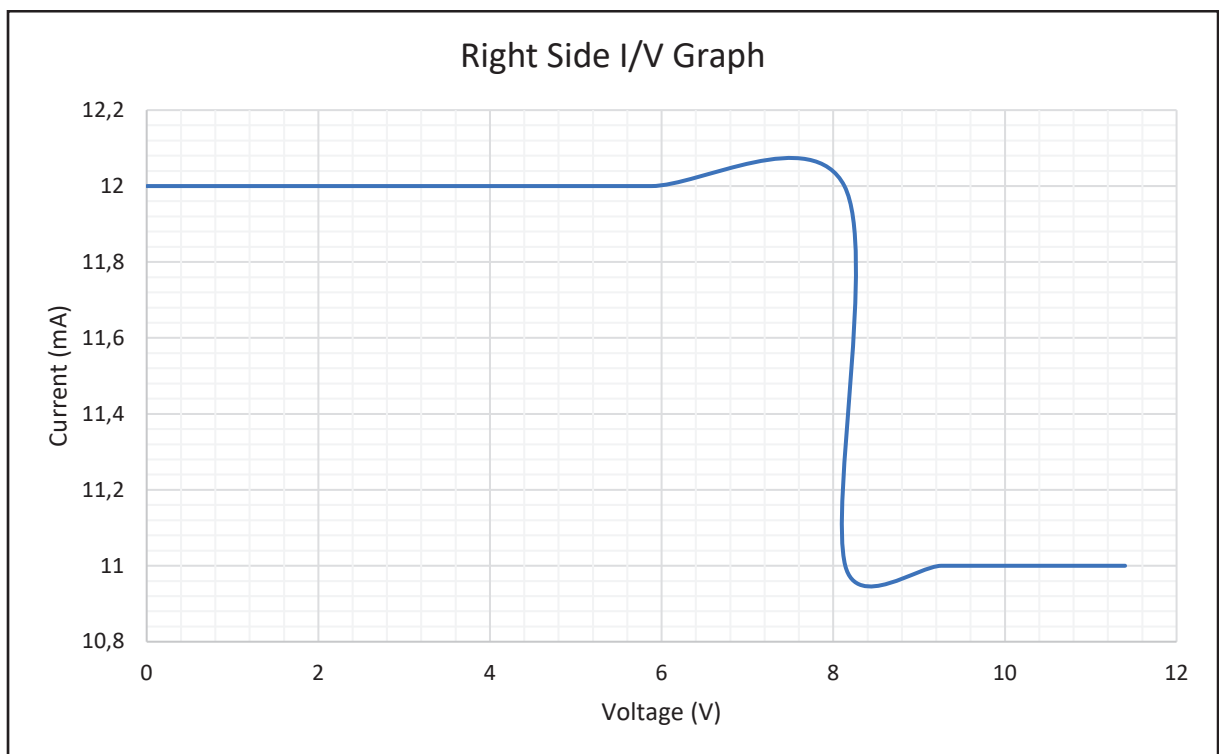

Graph III

Parallel Connection	Left side open - Right side shaded		Left side shaded - Right side open	
	Voltage (V)	Current (mA)	Voltage (V)	Current (mA)
R_L (Ohm/Ω)	Voltage (V)	Current (mA)	Voltage (V)	Current (mA)
1000	17,8	19	18,02	19
900	17,7	21	17,86	21
800	17,58	23	17,64	23
700	17,34	26	17,46	26
600	17	30	17,06	30
500	16,6	35	16,58	35
400	16	42	15,8	41
300	14,65	51	13,55	47
200	10,5	55	9,47	48
100	5,4	56	4,97	51
0	0,015	58	0,015	53

Table-40

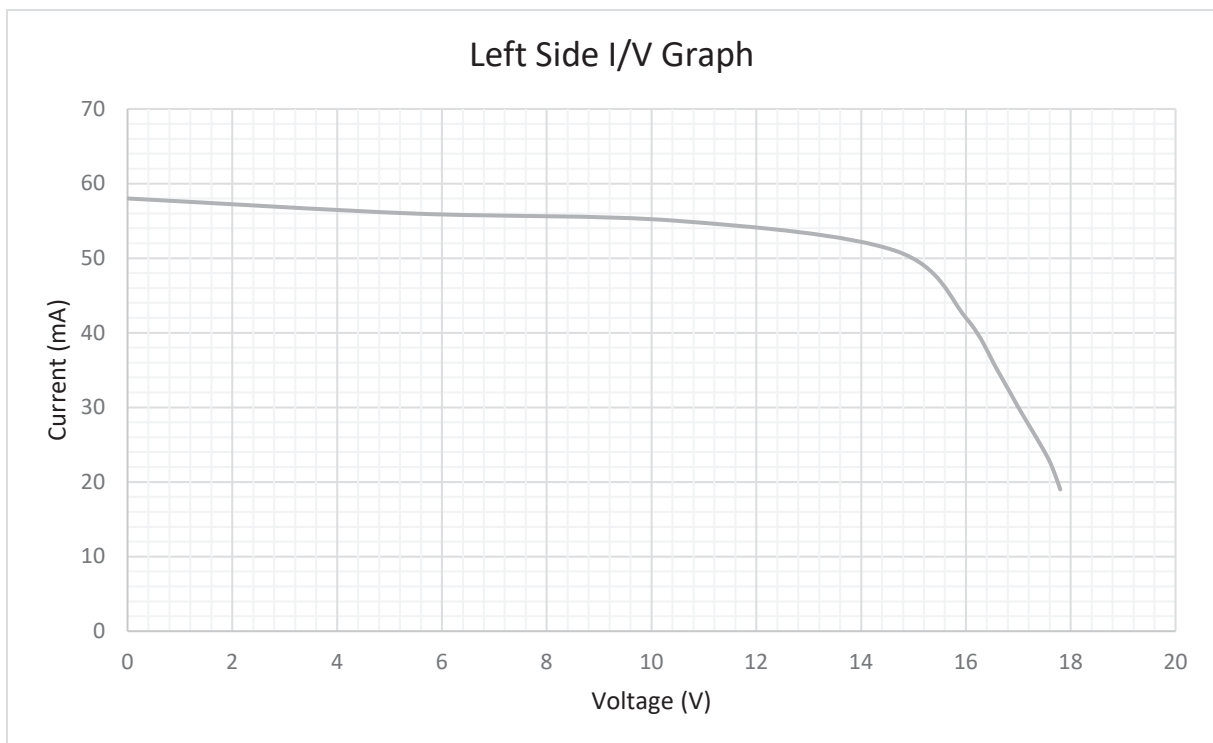

Graph IV

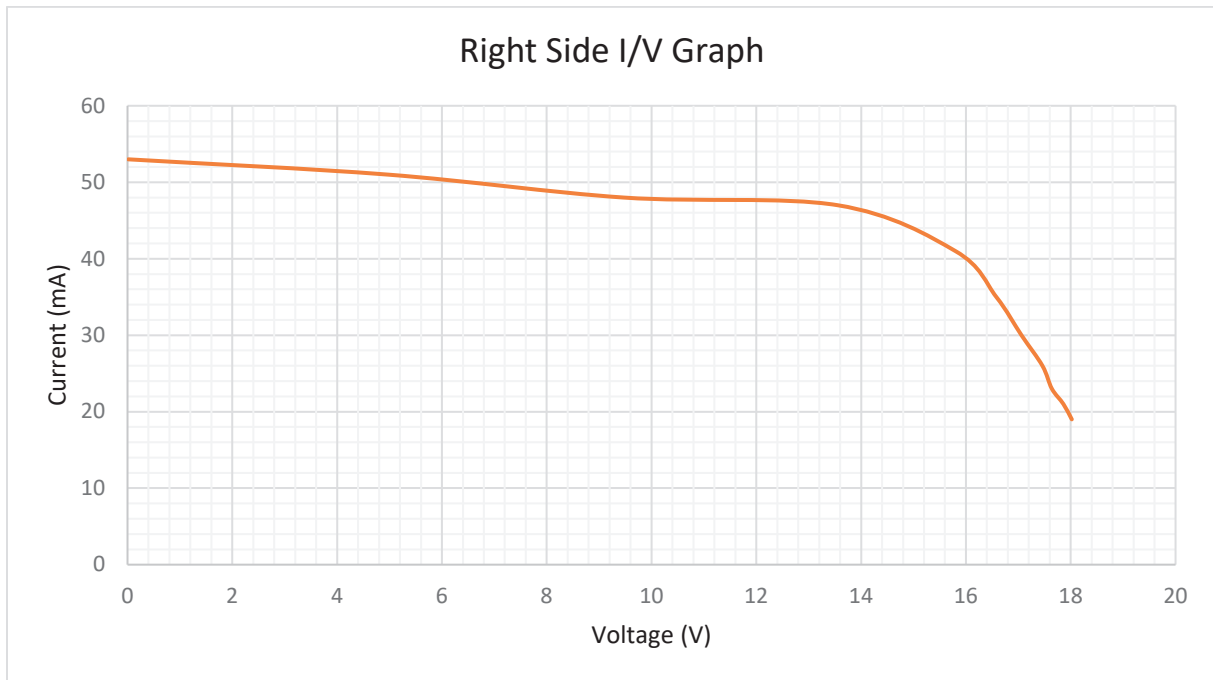

Graph V

4.11 Experiment-11 Examination of Effect of Bypass Diode in Photovoltaic Panels

Modules required for the experiment;

- Light Angle Adjustable Solar Panel,
- Monophase Switching Module,
- Energy Distribution Module,
- PC Interface Module, (Optional)
- Light Source Control Module (LSC),
- AC/DC Measurement Module (MM),
- Electronic Potentiometer Module (EP),
- Diode Module

Experiment Connection;

1. Start by connecting the energy input to the Energy Distribution Module using a Banana Jack cables for safety reasons.
2. Subsequently, connect the Energy Distribution Module using Banana Jack cables.
3. Next, connect the power input for the Light Source Control module and the lamps of the PV panel to the industrial socket located on the module with the Banana Jack cables.
4. To view the measurement values, make the power connections of the Digital AC/DC Measurement Module:
 - Connect the "+" terminal of the first PV panel to the "+" terminal of the voltmeter on the module.
 - Connect the "-" terminal of the first panel to the "+" terminal of the second PV panel.
 - Finally, connect the "-" terminal of the second panel to the "-" terminal of the voltmeter.
5. The ammeter should be connected in series with the PV panels and the potentiometer, while the voltmeter should be connected in parallel with the potentiometer.

6. To complete the experiment setup, connect the "+" terminal of a panel to the cathode of a diode in the Diode Module, and connect the "-" terminal of the panel to the anode of the diode.
7. If you would like to view the measured data and control your light source and potentiometer via computer, make the power connection of the PC Interface Module and connect the AC/DC Measurement Module and Light Source Control Module to the PC Interface Module with CAT6 cable.

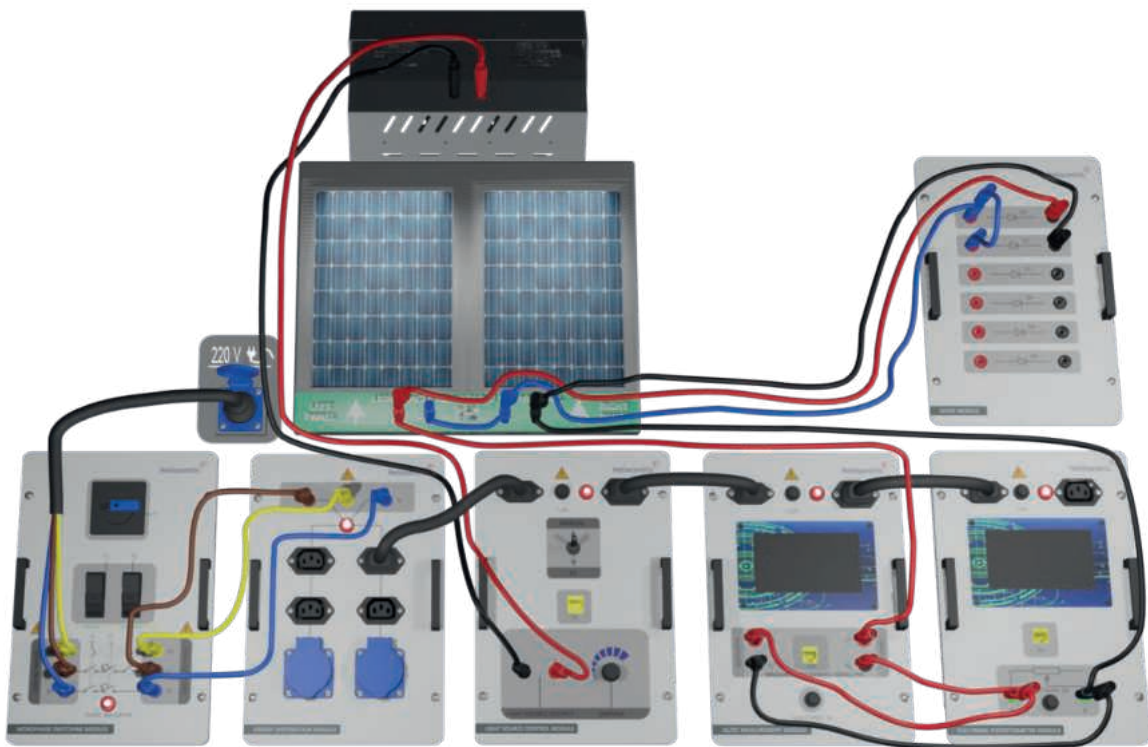

Figure-49. Installation Image of Examination of Effect of Bypass Diode in Photovoltaic Panels

Stages of the Experiment;

1. Set up the connection as specified in Figure-49. Ensure a constant level of light in the laboratory by creating an average scenario. Any alterations to the positions of the lamps or curtains will have an impact on the experimental outcomes.
2. Align the angle of incidence of light to the photovoltaic panel to 90° (summer season) and ensure that the panel surface is parallel to the ground. To achieve this, make the

necessary adjustments by pulling the pins on the module and placing them in their correct positions. Set the potentiometer to the highest level on the LSC module.

3. Set the Potentiometer Module to 1000Ω .
4. Ensure the bypass diodes are connected in reverse.
5. To conduct the experiment, cover one panel with paper or a non-transparent material, as demonstrated in Figure-50. Then, reduce the load by 100Ω and record the voltage and current measurements from the MM Module in Table-41.
6. Afterward, cover the other panel as shown in Figure-51. Record the values displayed by the voltmeter and ammeter in the DM Module in Table-41.

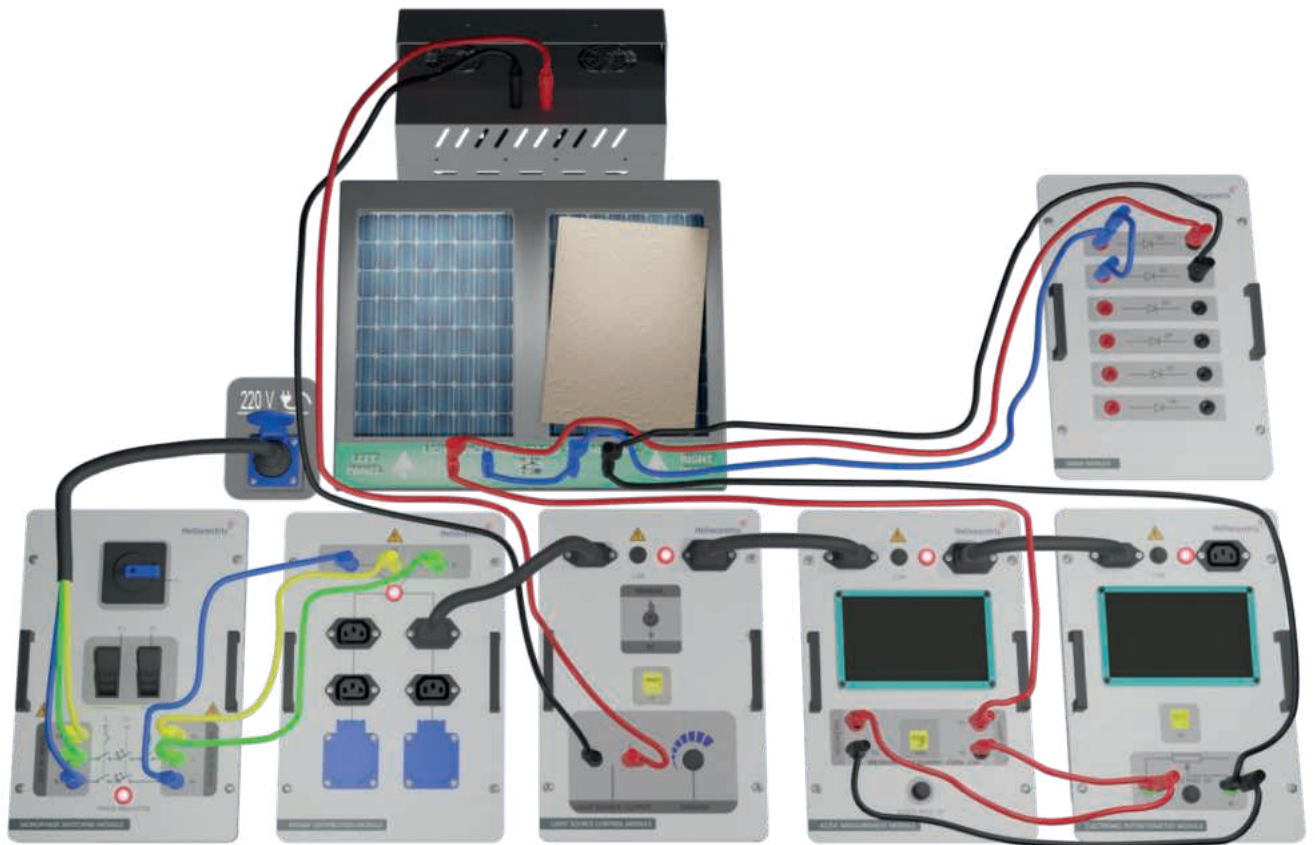

Figure-50. Installation Image of Examination of Effect of Bypass Diode in Photovoltaic Panels (with Shadow Effect)

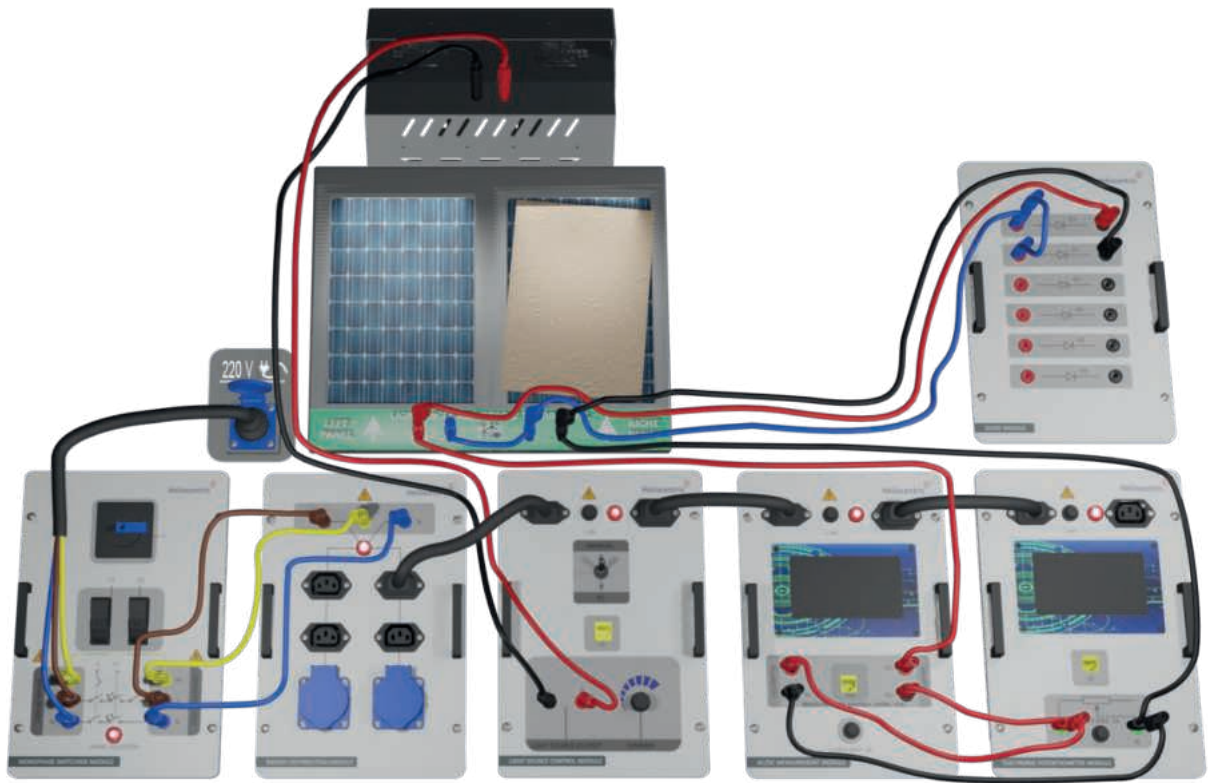

Figure-51. Installation Image of Examination of Effect of Bypass Diode in Photovoltaic Panels (with Shadow Effect)

Series Connection	Left side open - Right side shaded with Bybass Diode		Left side shaded - Right side open with Bybass Diode	
	Voltage (v)	Current (mA)	Voltage (v)	Current (mA)
R_L (Ohm/ Ω)				
1000	19,62	20	19,58	21
900	19,6	22	19,46	23
800	19,48	25	19,35	25
700	19,4	29	19,23	29
600	19,25	33	19,05	33
500	19,1	40	18,82	39
400	18,72	50	18,39	48
300	17,61	61	17,3	60
200	14	72	14,08	73
100	7,31	76	7,62	79
0	0,002	78	0,02	80

Table-41

7. After recording these measurements, connect the panels in parallel as shown in Figure-52 and Figure-53, and repeat the same experiment, measuring the voltage and current in the MM module, and record them in Table-42.

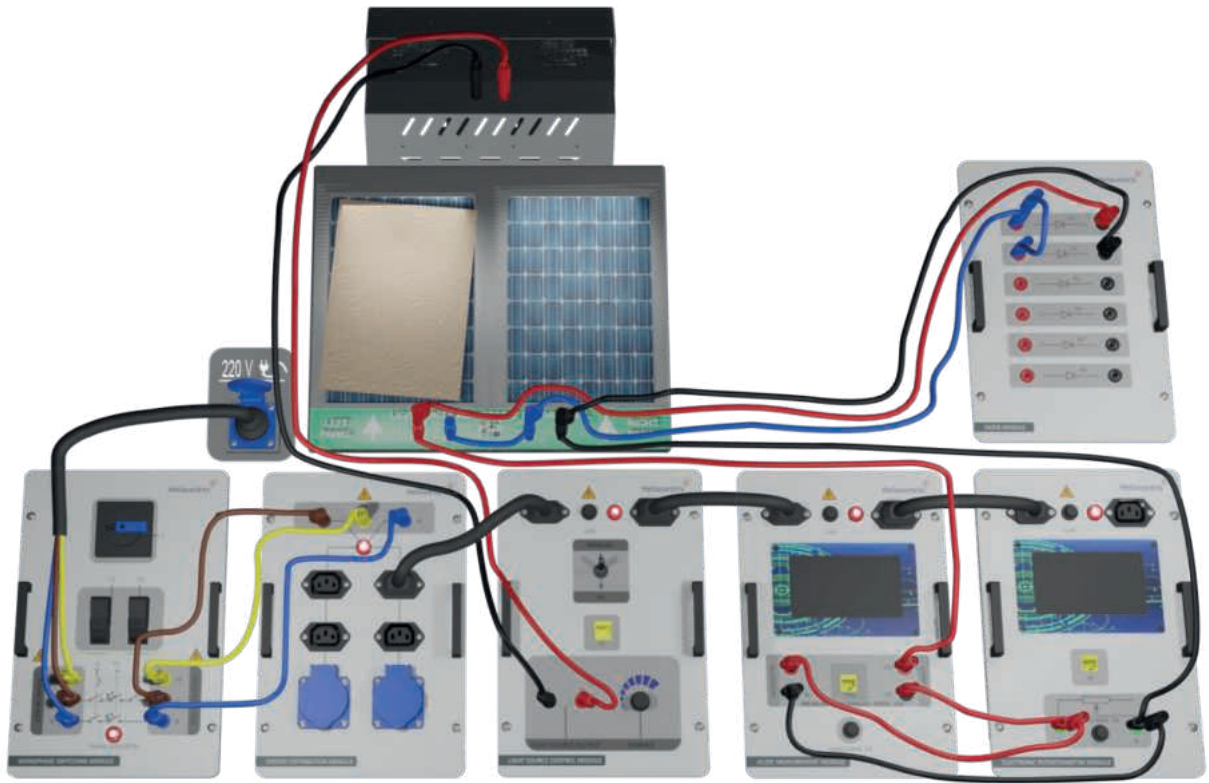

Figure-52. Installation Image of Examination of Effect of Bypass Diode in Photovoltaic Panels (with Shadow Effect)

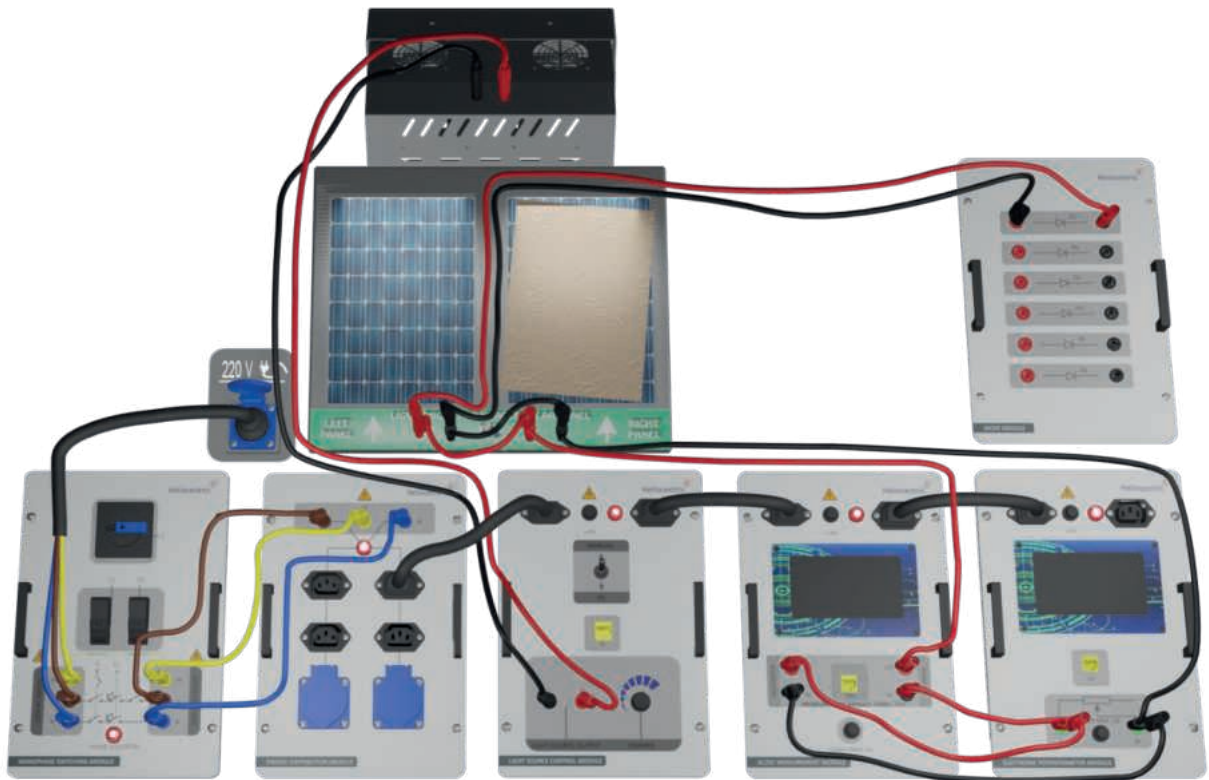
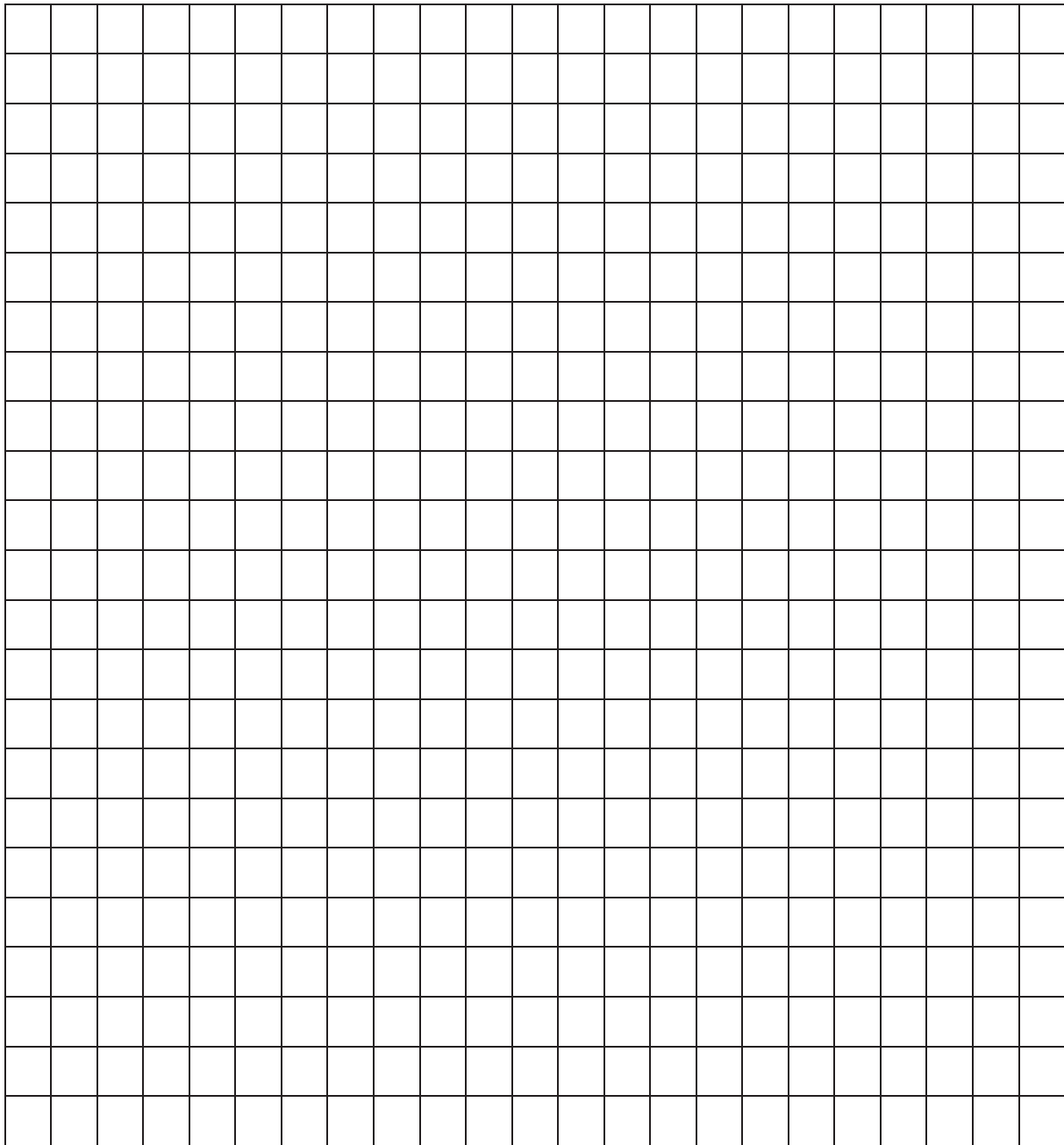

Figure-53. Installation Image of Examination of Effect of Bypass Diode in Photovoltaic Panels (with Shadow Effect)

Series Connection	Left side open - Right side shaded with Bybass Diode		Left side shaded - Right side open with Bybass Diode	
	Voltage (v)	Current (mA)	Voltage (v)	Current (mA)
R_L (Ohm/Ω)				
1000	16,55	17	19,05	20
900	16,48	19	18,98	22
800	16,33	21	18,85	23
700	16,16	24	18,76	25
600	15,92	28	18,71	28
500	15,49	32	18,55	32
400	14,43	38	18,21	38
300	12,44	43	17,46	46
200	9,11	48	12,82	67
100	4,99	52	7,51	78
0	0,015	54	0,02	81

Table-42



Graph-1

8. Draw the current/voltage curve of PV panel with bypass diode from the measured data.

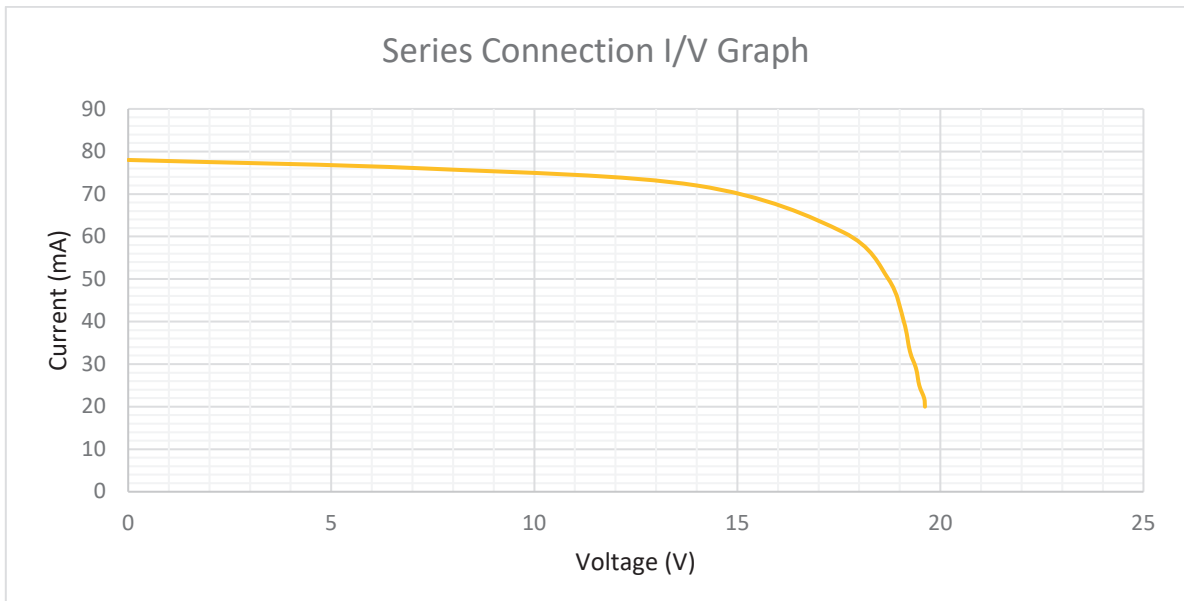

Graph VI

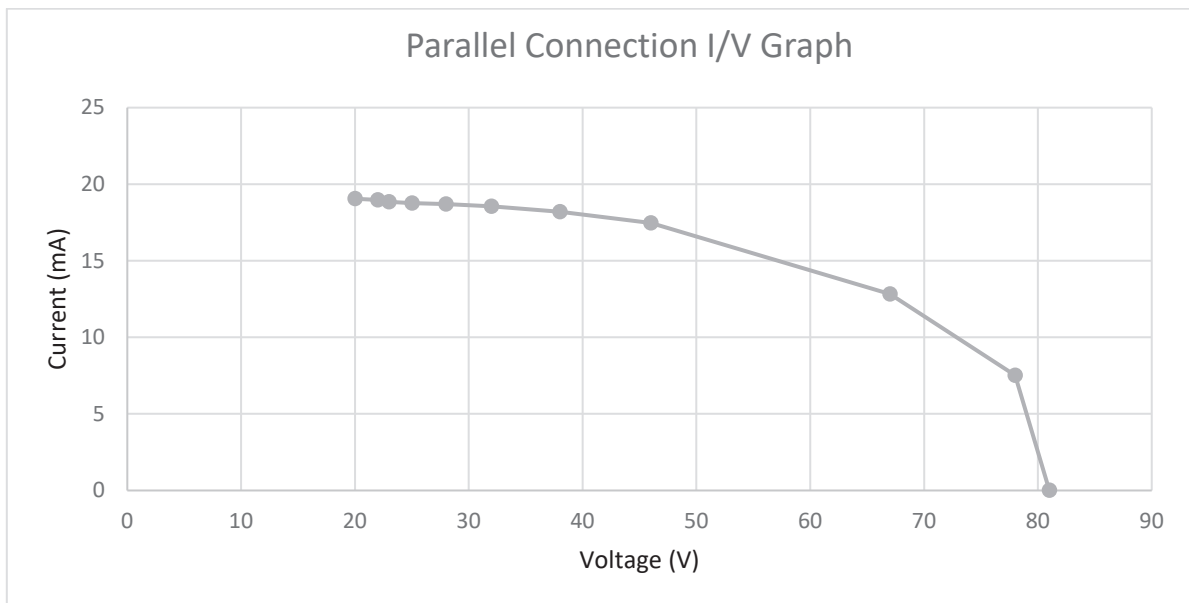

Graph VII

Research Questions about the Experiment;

1. Explain the connection direction of the bypass diode.
2. Show the effect of the bypass diode by drawing an equivalent circuit.
3. Compare the graphs you have drawn with the graphs given.

Answers to the Research Questions;

1. The bypass diode is connected in parallel with the photovoltaic cell or a series of cells, but in reverse polarity relative to the normal current flow. Under normal operation, the diode does not conduct because the voltage generated by the solar cells forward biases the diode. However, if a cell becomes shaded or damaged, causing its voltage to drop, the diode becomes forward biased and allows current to bypass the affected cell, preventing the overall current from being significantly reduced.
2. In an equivalent circuit, the bypass diode is shown in parallel with each solar cell or string of cells. When the cell is functioning properly, the current flows through the cell. If the cell is shaded or malfunctioning, the diode becomes forward biased and conducts, allowing current to bypass the cell. The circuit would consist of the solar cell as a current source in series with a diode (representing the solar cell itself), and a second diode (bypass diode) placed in parallel across the solar cell.

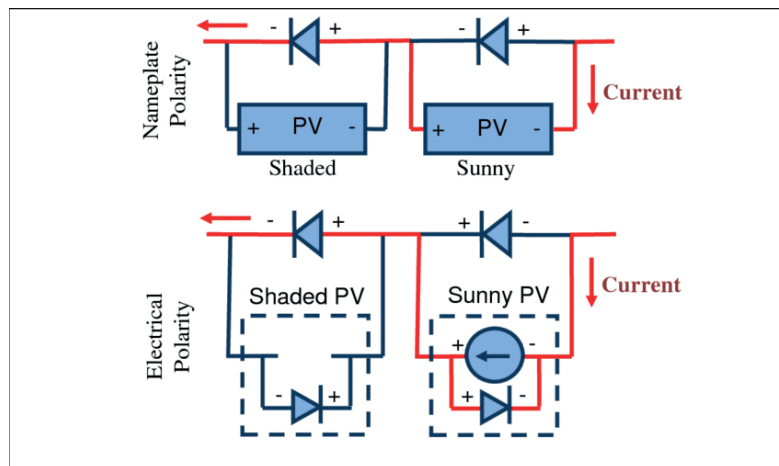

3. Compare the graphs.

4.12 Experiment-12 Examination of Solar Panel Simulator

Modules required for the experiment;

- Monophase Switching Module,
- Energy Distribution Module,
- PC Interface Module, (Optional)
- Solar Panel Simulator Module,
- AC/DC Measurement Module (MM),
- Electronic Potentiometer Module (EP),

Experiment Connection;

1. Firstly, connect the energy input to the Energy Distribution Module using a Banana Jack cables for safety reasons.
2. Subsequently, connect the Energy Distribution Module using Banana Jack cables.
3. The next step is to make the power connections to the Solar Panel Simulator Module and then install the experiment by making the connections using the banana jack cable as shown in Figure-54.

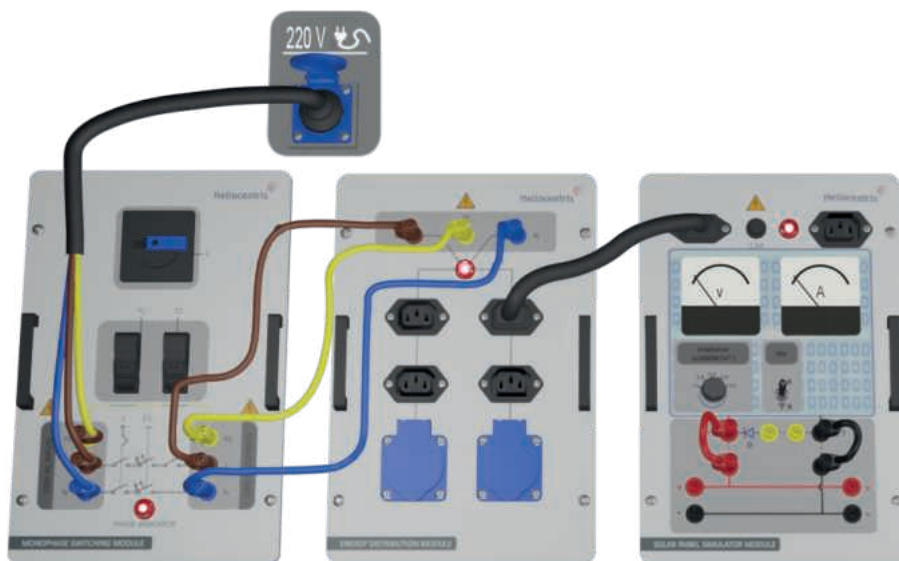

Figure-54. Installation Image of Solar Panel Examination of Solar Panel Simulator

Stages of the Experiment;

1. Set the Irradiance selector switch to 0.2.
2. Set the A-B selection switch to position A. This selector switch will display the value of the photovoltaic panel open circuit voltage (VOC). For position A, this value will be approximately 12V, for position B, it will be 17V.
3. Read the open circuit voltage of the photovoltaic panel from the voltmeter and record it in Table-43.
4. Repeat the same measurement by switching the selector switch to position B. Record the measured voltage value in Table-43.
5. Repeat the same measurements by switching the irradiance selection switch to 0.4, 0.6, 0.8, and 1, respectively. Record the measurement results in Table-43.
6. Make the connection shown in Figure-54 to measure the short-circuit current of the photovoltaic panel. The A-B selector has no effect on the short-circuit current (see Figure-55).
7. Set the irradiance selector switch to 0.2 and record the measured values in Table-43. Make the same measurements by setting the irradiance selector switch to 0.4, 0.6, 0.8, and 1, respectively, and record the results in Table-43.

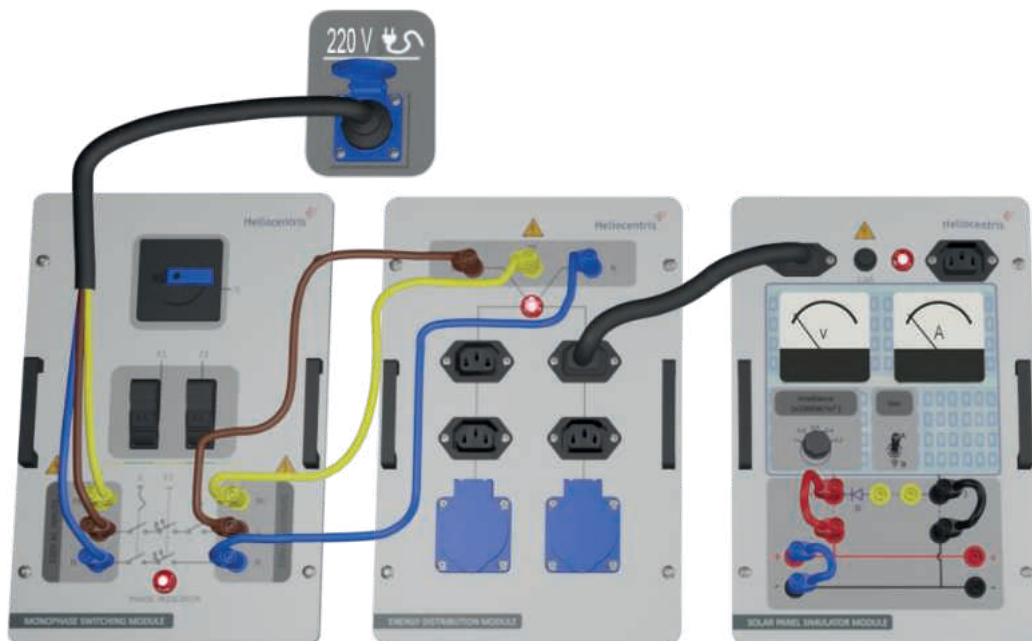

Figure-55. Installation Image of Solar Panel Examination of Solar Panel Simulator (Short-Circuit Current)

Irradiance	Panel A Open Circuit Voltage (V)	Panel B Open Circuit Voltage (V)	Panel Short Circuit Current (mA)
1	12	15,85	1610
0,8	12,18	15,94	1310
0,6	11,83	15,96	939
0,4	11,73	15,91	644
0,2	11,69	15,50	310

Table-43

- To examine the series connection of the photovoltaic panels, connect them as shown in Figure 56. Set the selector switches on both modules to A.

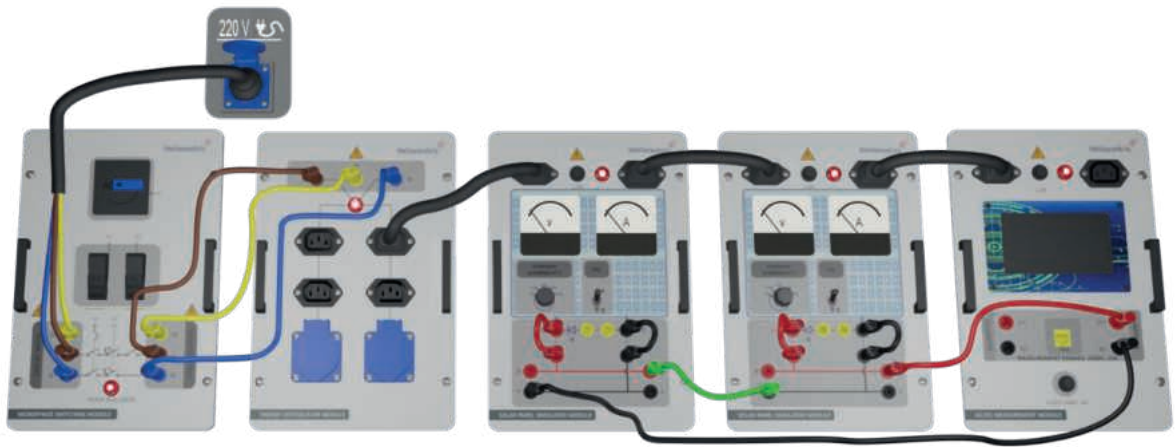

Figure-56. Installation Image of Solar Panel Examination of Solar Panel Simulator (Series Connection for Open-Circuit)

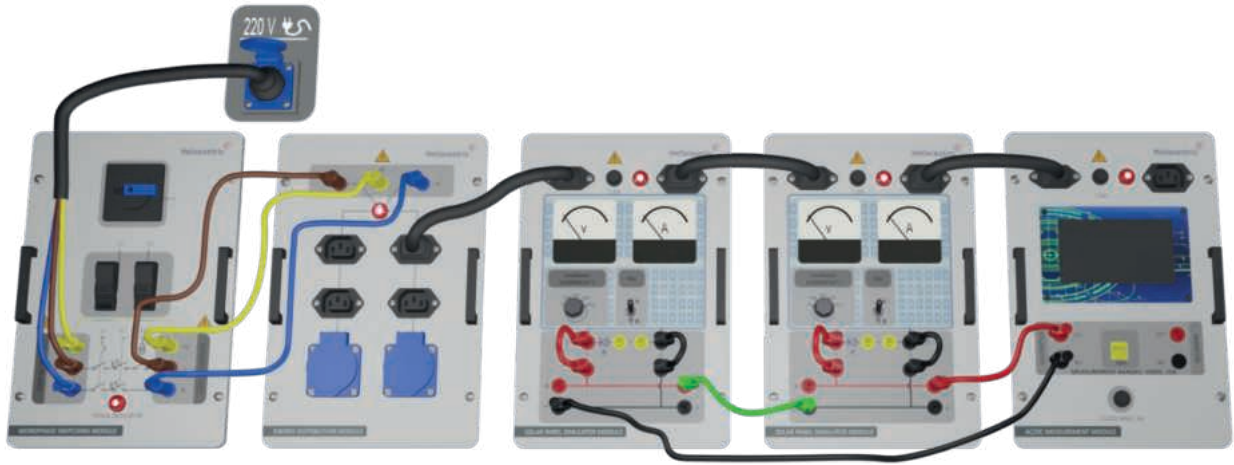

Figure-57. Installation Image of Solar Panel Examination of Solar Panel Simulator (Series Connection for Short-Circuit)

9. Set the irradiance selector on both modules to 0.2. Measure the open-circuit voltage and short-circuit current of the series connection using the voltmeter in the MM module and record them in Table-44.
10. Repeat the same measurements by setting the irradiance selector in both modules to 0.4, 0.6, 0.8 and 1 respectively. Record the results in Table-44.

Irradiance	Panel A Open Circuit Voltage (v)	Panel B Open Circuit Voltage (v)	Panel Short Circuit Current (mA)
1	24,42	31,70	1610
0,8	24,18	31,88	1310
0,6	22,88	31,92	939
0,4	22,55	31,82	644
0,2	22,10	31,00	310

Table-44

11. Set the selector switches in both modules to position B. Repeat the same measurements. Record the results in Table-44.
12. To examine the parallel connection of the photovoltaic panels, connect them as shown in Figure 58. Set the selector switches on both modules to A.
13. Set the irradiance selector on both modules to 0.2. Measure the open-circuit voltage and short-circuit current of the series connection using the voltmeter in the MM module and record them in Table-45.
14. Repeat the same measurements by setting the irradiance selector in both modules to 0.4, 0.6, 0.8 and 1 respectively. Record the results in Table-45.

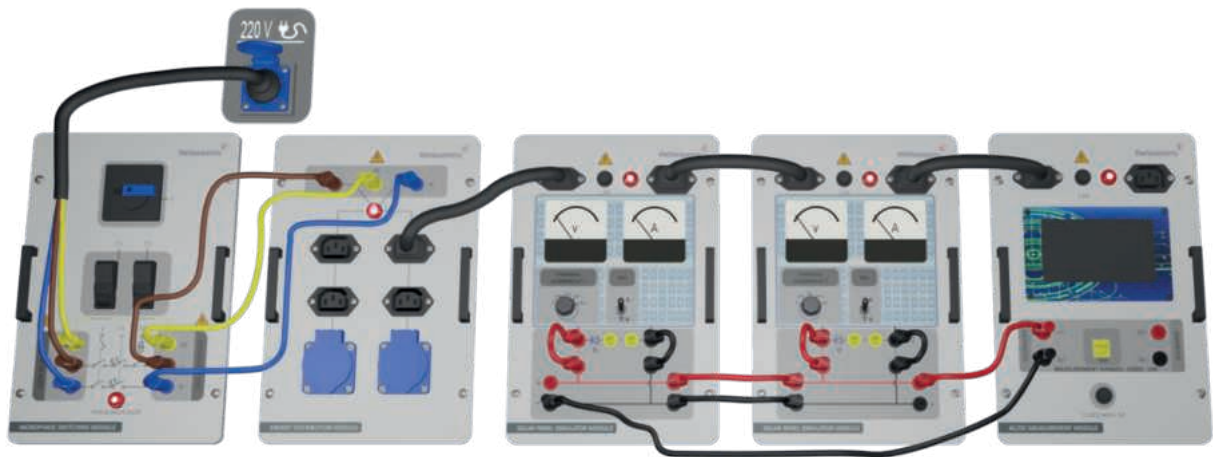

Figure-58. Installation Image of Solar Panel Examination of Solar Panel Simulator (Parallel Connection)

15. Set the selector switches in both modules to position B. Repeat the same measurements. Record the results in Table-45.

Irradiance	Panel A Open Circuit Voltage (v)	Panel B Open Circuit Voltage (v)	Panel Short Circuit Current (mA)
1	12	15,85	3240
0,8	12,18	15,94	1220
0,6	11,83	15,96	1878
0,4	11,73	15,91	1298
0,2	11,69	15,50	620

Table-45

16. Connect the solar panel simulators in series again as shown in Figure-59 and connect the EP module as load.
17. Then set the potentiometer to 1000 ohms and record the measurements in Table-46 by setting to the values given in the table.
18. Using the provided data, create a Current/Voltage graph and a Power/Voltage graph in Graph-1.

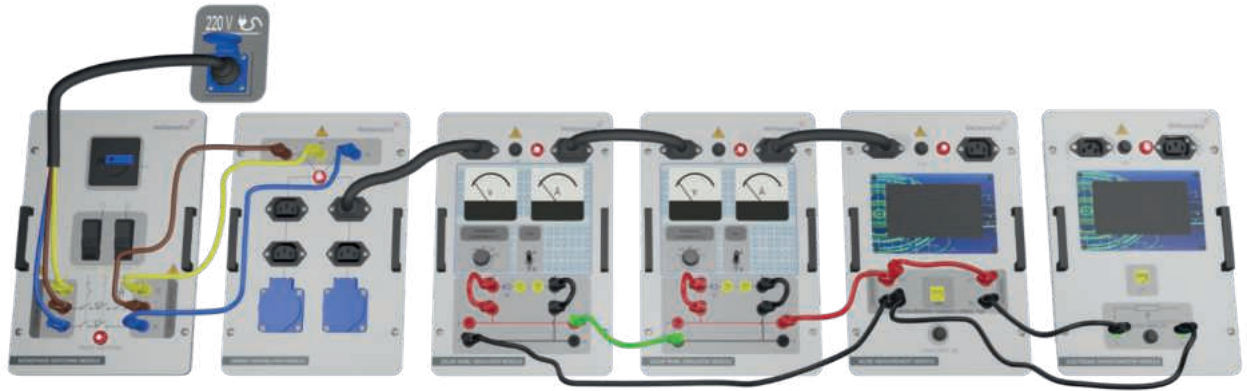
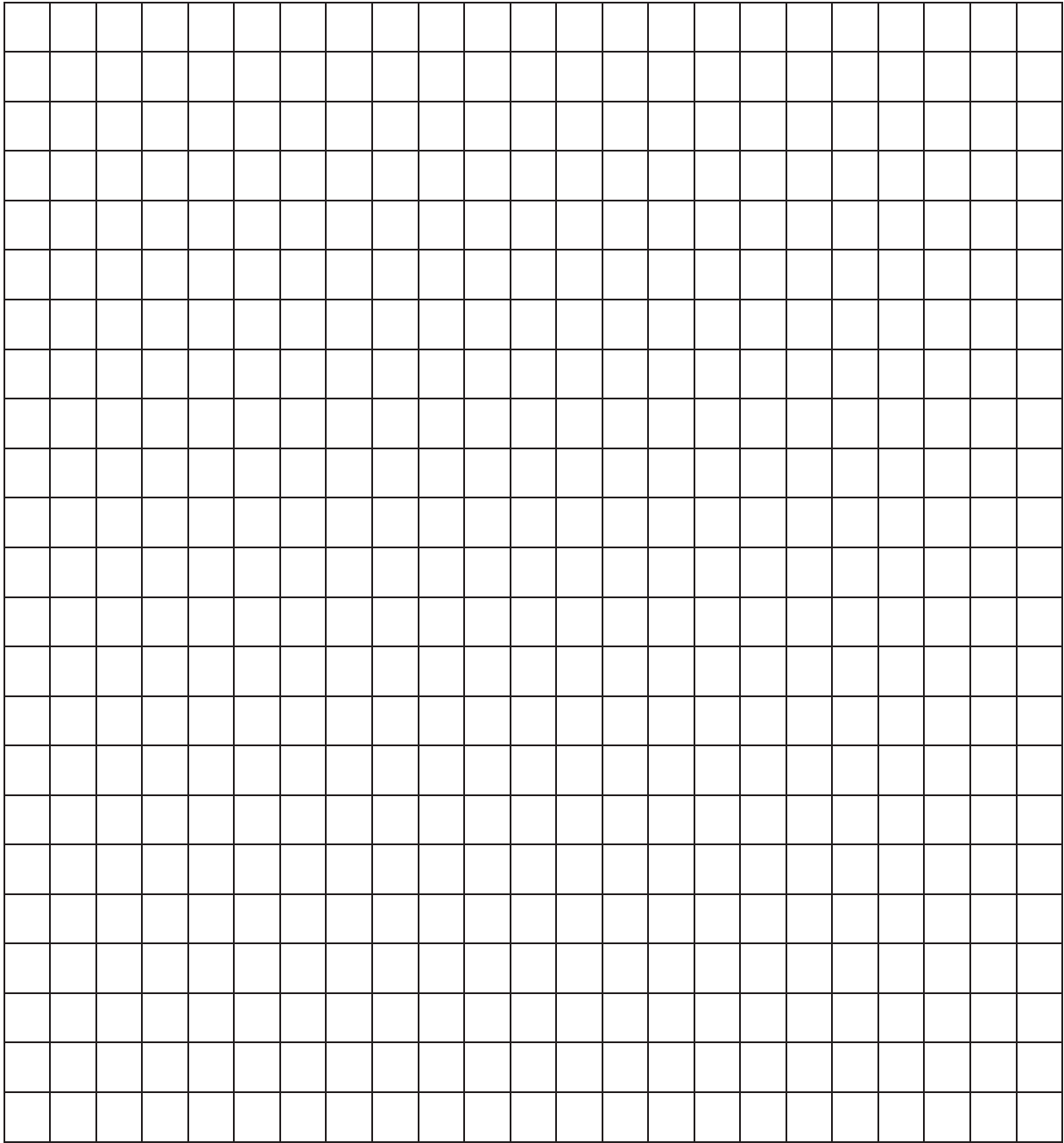

Figure-59. Installation Image of Solar Panel Examination of Solar Panel Simulator (Loaded)

For Switch A	Without Bypass Diode – Irradiance %100				Without Bypass Diode – Irradiance %60				Without Bypass Diode – Irradiance %20				
	R_L (ohm/ Ω)	Voltage (V)	Current (mA)	Power (mW)	Voltage (V)	Current (mA)	Power (mW)	Voltage (V)	Current (mA)	Power (mW)	Voltage (V)	Current (mA)	Power (mW)
1000	23,43	24,00	24,00	562,32	24,00	25,00	600	23,60	25,00	590			
900	23,40	27,00	28,00	631,8	23,75	28,00	665	23,60	27,00	637,2			
800	23,40	30,00	31,00	702	23,66	31,00	733,46	23,60	30,00	708			
700	23,38	34,00	35,00	794,92	23,58	35,00	825,3	23,60	35,00	826			
600	23,37	40,00	41,00	934,8	23,54	41,00	965,14	23,60	41,00	967,6			
500	23,36	48,00	50,00	1121,28	23,51	50,00	1175,5	23,60	49,00	1156,4			
400	23,36	60,00	61,00	1401,6	23,48	61,00	1432,28	23,60	61,00	1439,6			
300	23,34	80,00	81,00	1867,2	23,44	81,00	1898,64	23,58	82,00	1933,56			
200	23,28	121,00	121,00	2816,88	23,36	121,00	2826,56	23,50	122,00	2867			
100	23,12	240,00	243,00	5548,8	23,28	243,00	5657,04	22,50	233,00	5242,5			
50	23,90	485,00	465,00	11591,5	22,70	465,00	10555,5	15,12	310,00	4687,2			
40	23,28	590,00	576,00	13735,2	22,70	576,00	13075,2	12,18	310	3775,8			
30	23,10	790,00	754,00	18249	22,28	754,00	16799,12	9,14	310,00	2833,4			
20	21,85	1.100,00	931,00	24035	18,72	931,00	17428,32	6,22	310,00	1928,2			
10	15,49	1.510,00	940,00	23389,9	9,64	940,00	9061,6	3,18	310,00	985,8			
5	8,41	1.610,00	942,00	13540,1	4,43	942,00	4173,06	1,62	310,00	502,2			
3	5,24	1.610,00	942,00	8436,4	3,07	942,00	2891,94	1,00	311,00	311			
0	0,43	1.610,00	943,00	692,3	0,25	943,00	235,75	0,08	311,00	24,88			

Table-46



Graph-1

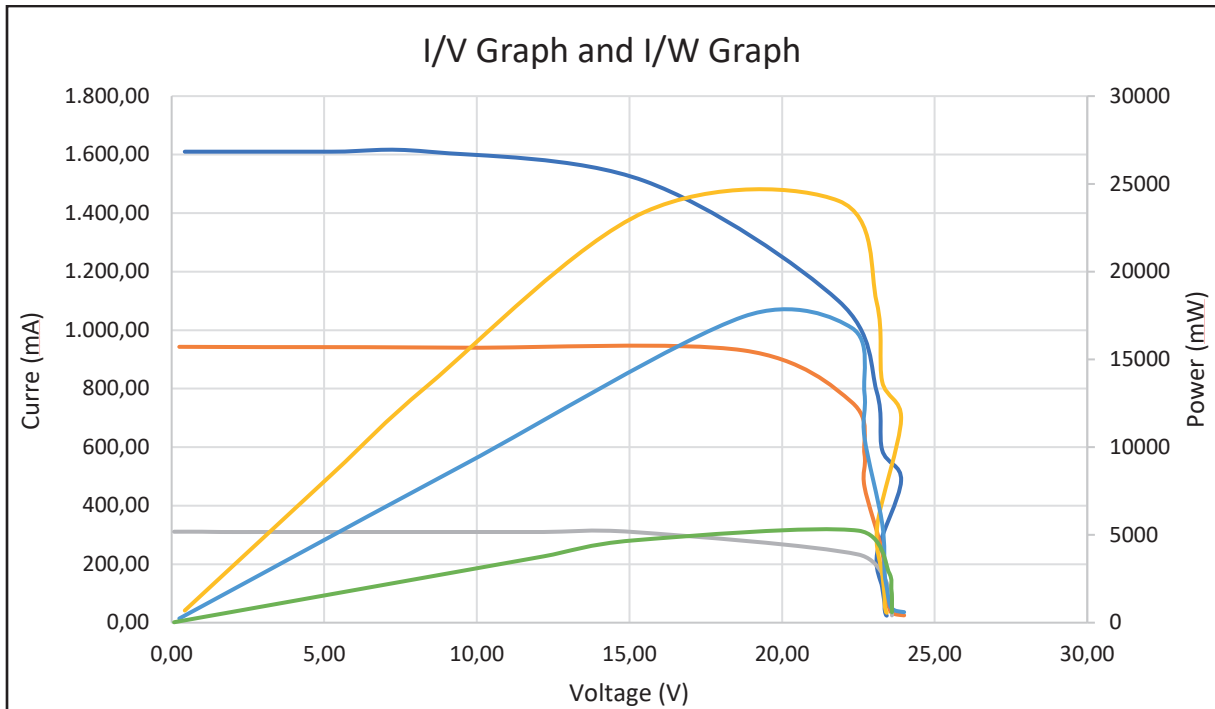

Graph VIII

19. Please compare the graph you have drawn with the one at the Graph VIII.
20. Re-measure the values by connecting the bypass diodes of the modules.
21. Create the Current/Voltage and Power/Voltage graphs using the data from Table-47 and Graph-2.

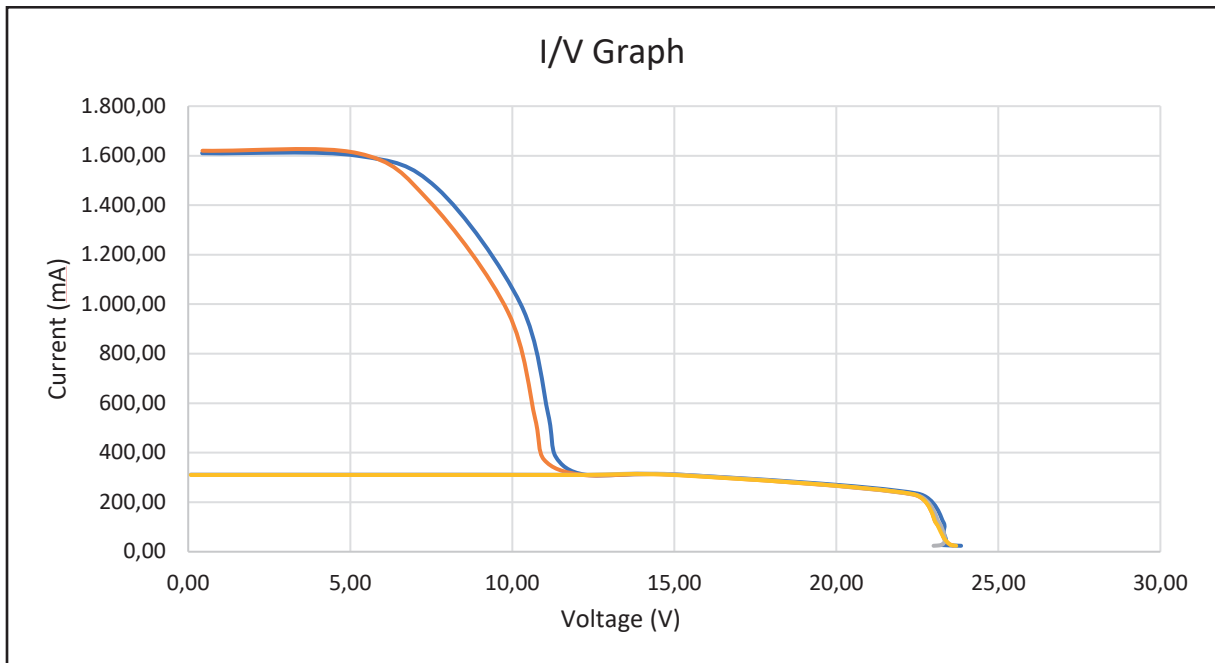

Graph IX

22. Please compare the graph you have drawn with the one at the Graph IX.

For Switch A	Left side %100 – Right side %20 with Bybass Diode		Left side %20 – Right side %100 with Bybass Diode		Left side %100 – Right side %20 without Bybass Diode		Left side %100 – Right side %20 without Bybass Diode		
	R_L (ohm/ Ω)	Voltage (V)	Current (mA)	Voltage (V)	Current (mA)	Voltage (V)	Current (mA)	Voltage (V)	Current (mA)
1000	23,85	23,60	25,00	23,00	24,00	23,70	24,00	23,70	24,00
900	23,25	23,56	27,00	23,20	26,00	23,54	27,00	23,54	27,00
800	23,32	23,50	30,00	23,28	30,00	23,50	30,00	23,50	30,00
700	23,36	23,45	35,00	23,31	34,00	23,45	35,00	23,45	35,00
600	23,37	23,40	40,00	23,34	40,00	23,42	40,00	23,42	40,00
500	23,38	23,36	48,00	23,34	48,00	23,36	48,00	23,36	48,00
400	23,36	23,30	60,00	23,35	60,00	23,30	60,00	23,30	60,00
300	23,31	23,25	80,00	23,30	80,00	23,22	80,00	23,22	80,00
200	23,30	23,06	120,00	23,16	119,00	23,06	119,00	23,06	119,00
100	22,50	22,37	231,00	22,42	231,00	22,35	233,00	22,35	233,00
50	15,22	15,14	310,00	15,22	311,00	15,13	309,00	15,13	309,00
40	12,26	12,20	310,00	12,27	311,00	12,20	310,00	12,20	310,00
30	11,34	10,98	372,00	9,20	312,00	9,14	310,00	9,14	310,00
20	11,11	10,71	535,00	6,25	312,00	6,22	310,00	6,22	310,00
10	10,26	9,87	968,00	3,20	312,00	3,18	310,00	3,18	310,00
5	7,67	7,41	1.420,00	1,63	312,00	1,62	310,00	1,62	310,00
3	5,21	5,23	1.610,00	1,00	312,00	1,00	310,00	1,00	310,00
0	0,43	0,44	1.620,00	0,08	312,00	0,08	310,00	0,08	310,00

Table-47

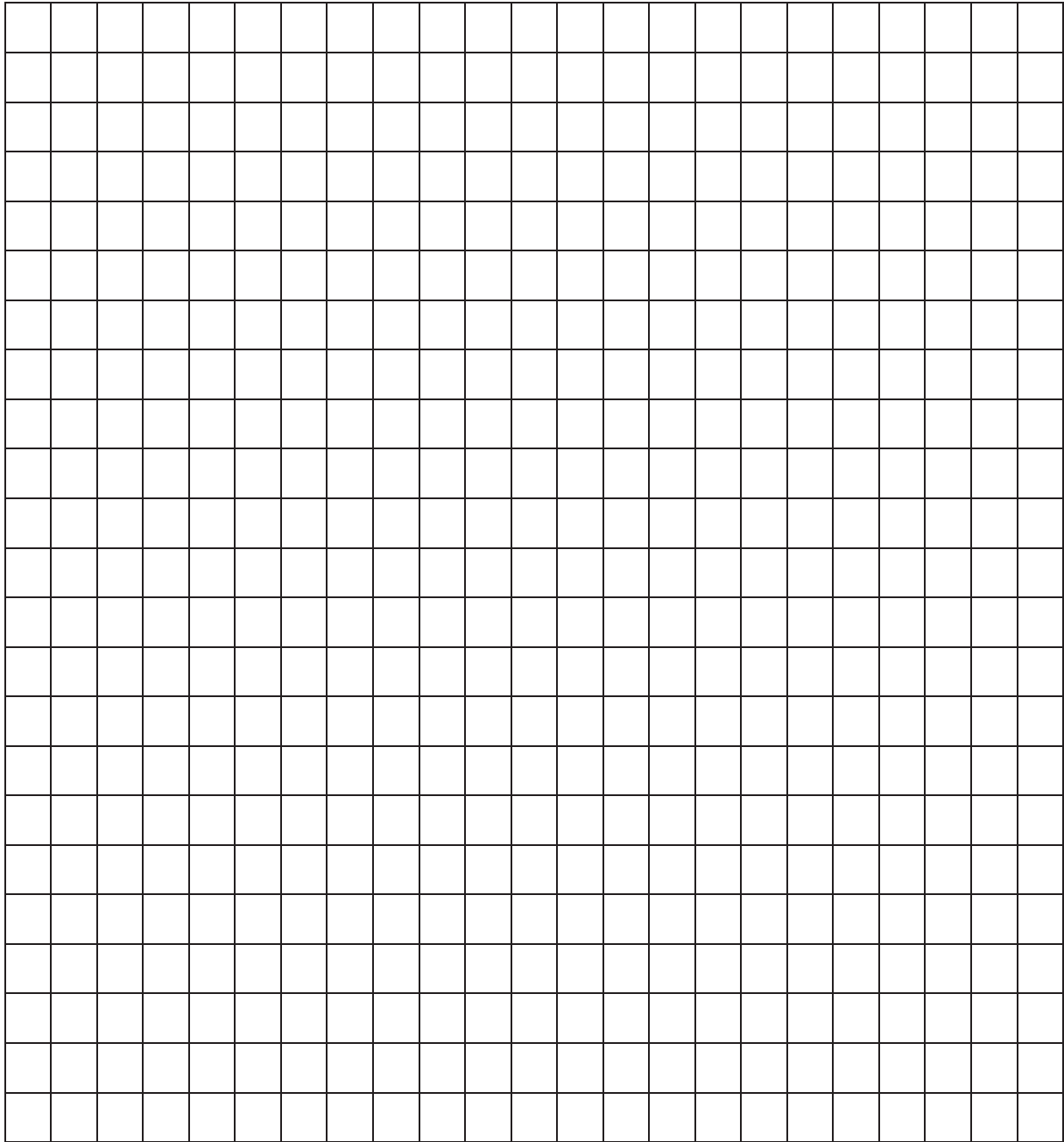

Graph-2

4.13 Experiment-13 Examination of Mismatching Effect in Photovoltaic Panels

Modules required for the experiment;

- Light Angle Adjustable Solar Panel,
- Monophase Switching Module,
- Energy Distribution Module,
- PC Interface Module, (Optional)
- Light Source Control Module (LSC),
- AC/DC Measurement Module (MM),

Experiment Connection;

1. Begin by connecting the energy input to the Energy Distribution Module using a Banana Jack cables for safety reasons.
2. Subsequently, connect the Energy Distribution Module using Banana Jack cables.
3. Next, connect the power input for the Light Source Control module and the lamps of the PV panel to the industrial socket located on the module with the Banana Jack cables.
4. To view the measurement values, establish the power connections of the AC/DC Measurement Module and set up the experiment by directly linking the Voltmeter on the module to the solar panel.
5. If you would like to view the measured data and control your light source via computer, make the power connection of the PC Interface Module and connect the AC/DC Measurement Module and Light Source Control Module to the PC Interface Module with CAT6 cable.

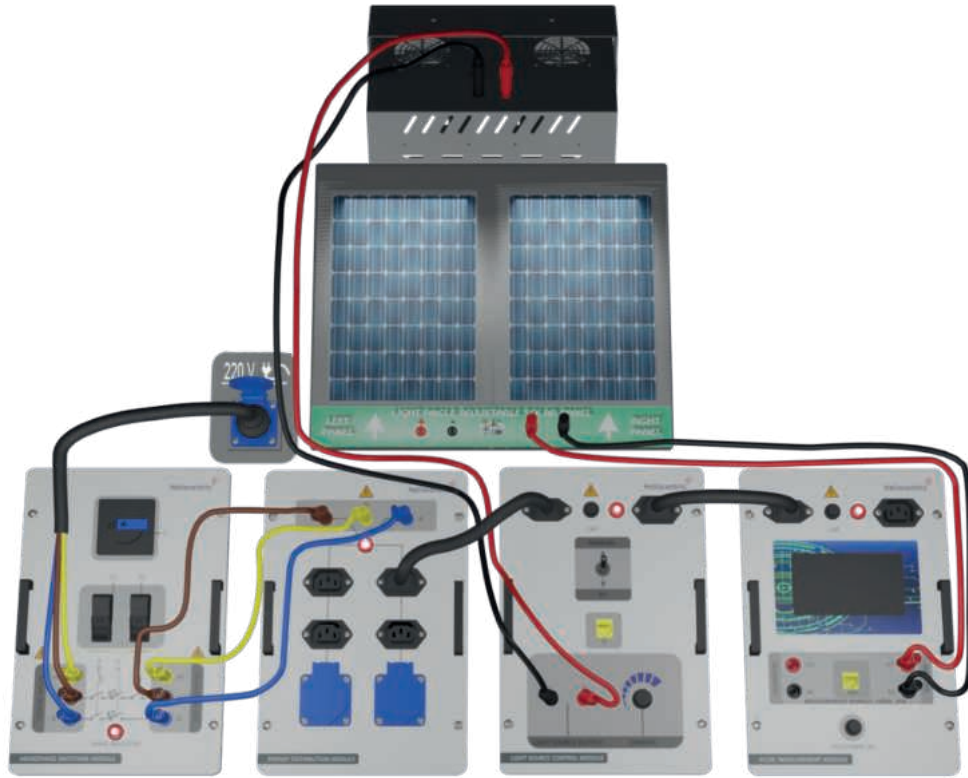

Figure-60. Installation Image of Examination of Mismatching Effect in Photovoltaic Panels

Stages of the Experiment;

1. Set up the connection as specified in Figure-60. Ensure a constant level of light in the laboratory by creating an average scenario. Any alterations to the positions of the lamps or curtains will have an impact on the experimental outcomes.
2. Align the angle of incidence of light to the photovoltaic panel to 90° (summer season) and ensure the panel surface is parallel to the ground. To achieve this, make the necessary adjustments by pulling the pins on the module and placing them in their correct positions. Set the potentiometer to the highest level on the LSC module.
3. Connect the ammeter in the MM Module to one of the panels; this value is referred to as Panel-1 short circuit current. Record the value shown by the ammeter in Table-48.
4. Connect the ammeter in the MM Module to the other panel; this value is referred to as Panel-2 short circuit current. Record the value shown by the ammeter in Table-48.

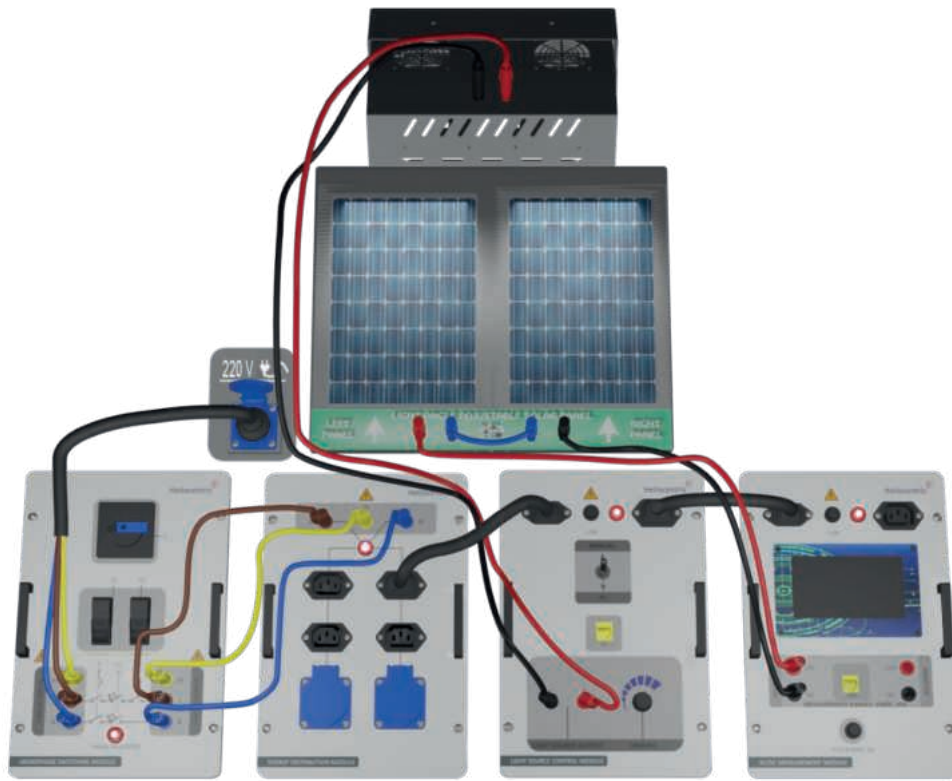
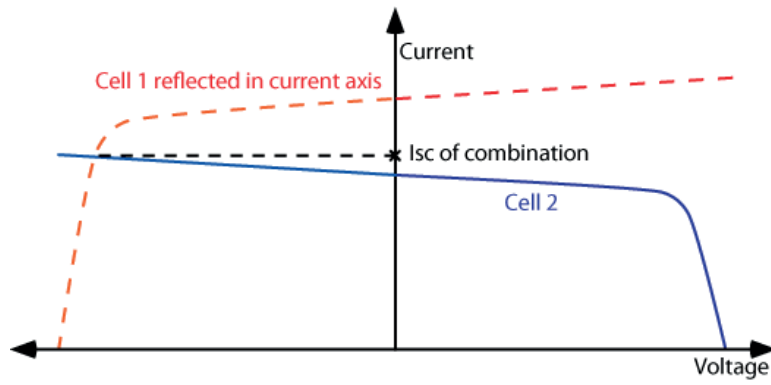

Figure-61. Installation Image of Examination of Mismatching Effect in Photovoltaic Panels

I_{sc} (Panel 1)	I_{sc} (Panel 2)	I_{sc} (Series)
78mA	61mA	61mA

Table-48

- Connect the panels in series as shown in Figure-61. Record the value displayed by the ammeter in the MM Module in Table-48. This value is referred to as the series short circuit current of the series connection.
- Examine the I/V characteristics of each panel individually under the same light power and compare them to Graph X.



Graph X – PV Panel Characteristics

4.14 Experiment-14 Examination of the Effect of Blocking Diode in Photovoltaic Panels

Modules required for the experiment;

- Light Angle Adjustable Solar Panel,
- Monophase Switching Module,
- Energy Distribution Module,
- PC Interface Module, (Optional)
- Light Source Control Module (LSC),
- AC/DC Measurement Module (MM),
- Accumulator Module,
- Diode Modul,

Experiment Connection;

1. Start by connecting the energy input to the Energy Distribution Module using a Banana Jack cables for safety reasons.
2. Subsequently, connect the Energy Distribution Module using Banana Jack cables.
3. Next, connect the power input for the Light Source Control module and the lamps of the PV panel to the industrial socket located on the module with the Banana Jack cables.
4. To view the measurement values, make the power connections of the Digital AC/DC Measurement Module and set up the experiment by connecting the Ammeter on the module correctly to the solar panel via the battery.
5. If you would like to view the measured data and control your light source and potentiometer via computer, make the power connection of the PC Interface Module and connect the AC/DC Measurement Module and Light Source Control Module to the PC Interface Module with CAT6 cable.

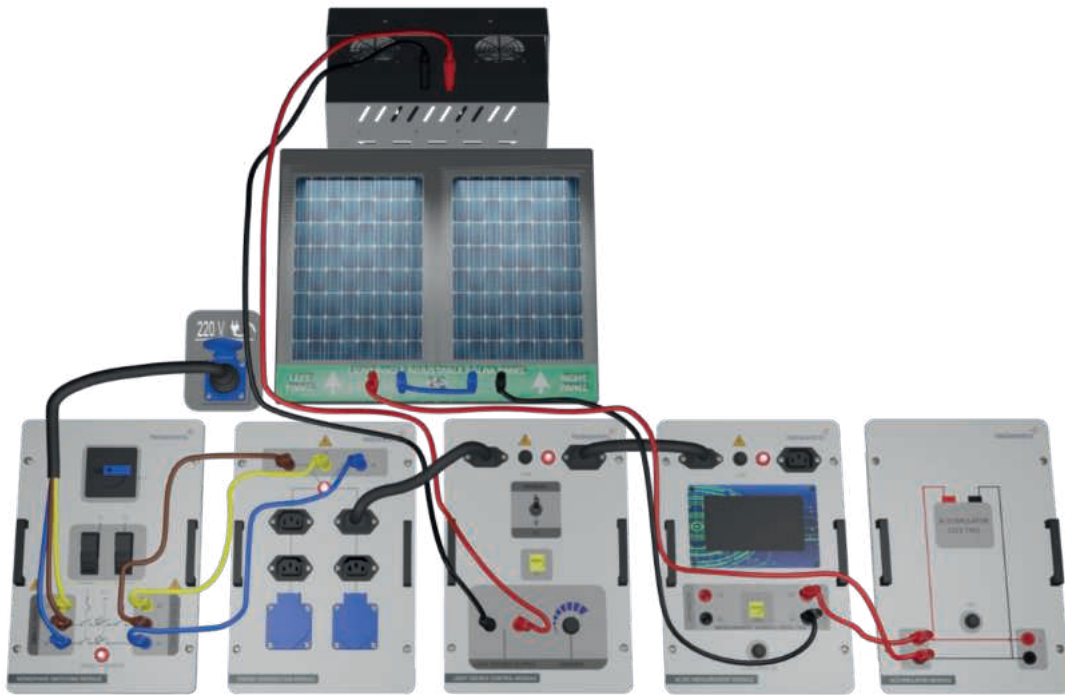

Figure-62. Installation Image of Examination of the Effect of Blocking Diode in Photovoltaic Panels

Stages of the Experiment;

1. Set up the connection as specified in Figure-62. Ensure a constant level of light in the laboratory by creating an average scenario. Any alterations to the positions of the lamps or curtains will have an impact on the experimental outcomes.
2. Align the angle of incidence of light to the photovoltaic panel to 90° (summer season) and ensure the panel surface is parallel to the ground. To achieve this, make the necessary adjustments by pulling the pins on the module and placing them in their correct positions. Set the potentiometer to the highest level on the LSC module.
3. Cover one of the panels with a sheet of paper or a non-transparent material.
4. Record the value displayed on the ammeter (without the diode) and note the direction of the current in Table-49.

Without diode	With Diode
-22mA	17mA

Table-49

5. Make the connection as shown in Figure-63 and observe the ammeter to determine if there is a current flow from the battery to the panels.
6. Cover one of the panels with a sheet of paper or a non-transparent material. Record the value displayed on the ammeter (with the diode) and note the direction of the current in Table-49.

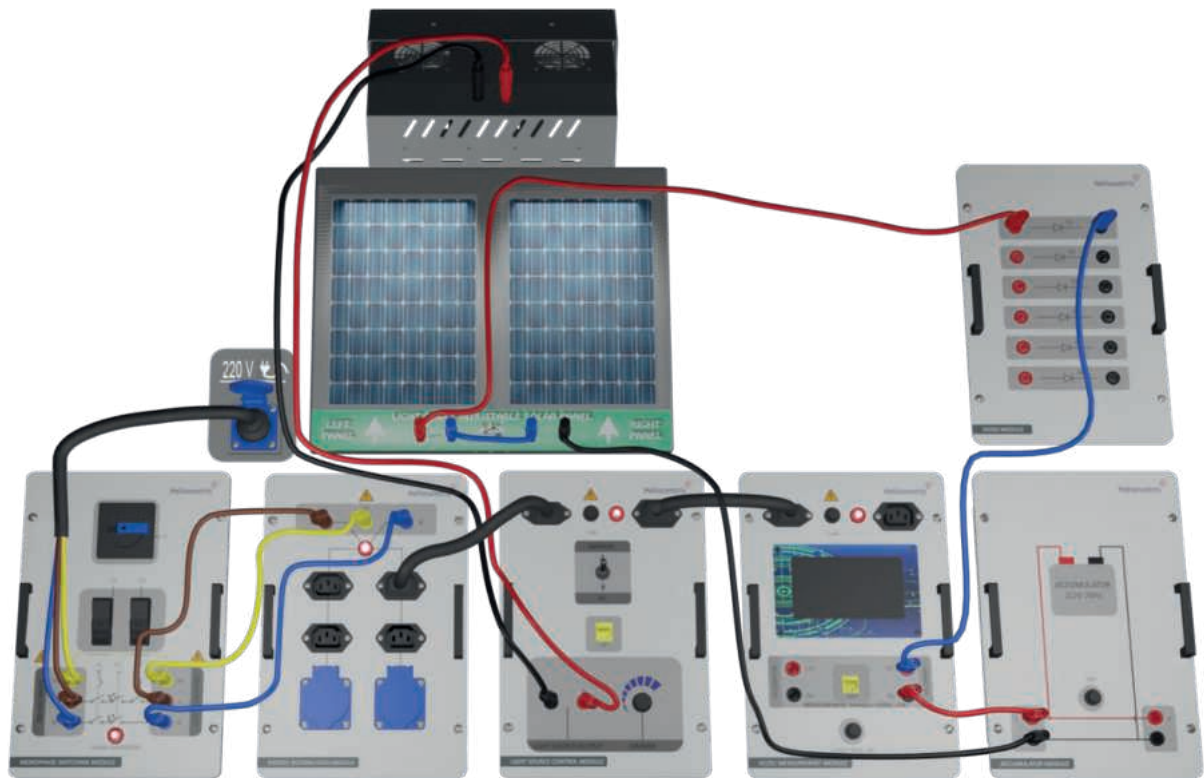

Figure-63. Installation Image of Examination of the Effect of Blocking Diode in Photovoltaic Panels

Research Questions about the Experiment;

1. Explain the blocking diode effect by drawing a figure.
2. Explain the problems that can arise from not using a blocking diode.

Answers to the Research Questions;

1. A blocking diode is connected in series with a photovoltaic panel to prevent reverse current flow, especially when the panel is not generating electricity, such as at night. When the panel produces electricity, the diode allows current to flow to the load or battery. However, when the panel is not producing power (e.g., in the dark), the diode blocks any reverse current from flowing back from the battery to the panel. The blocking diode acts like a one-way valve, ensuring current flows only in the desired direction.

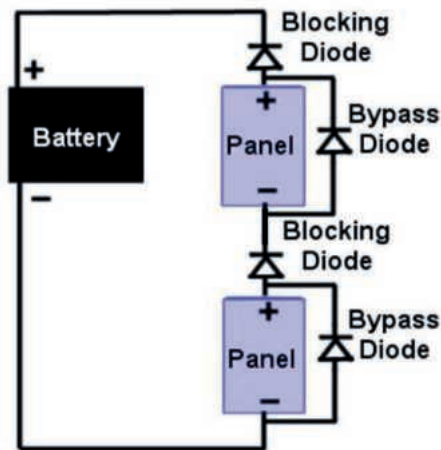

2. Without a blocking diode, several problems can occur:
 - I. **Reverse Current Flow:** When the photovoltaic panel is not generating electricity (e.g., at night or in low light conditions), current can flow back from the battery or other energy storage devices into the panel, causing energy losses.
 - II. **Damage to the Panel:** Reverse current can potentially damage the photovoltaic cells over time, especially if large amounts of current flow through them in the wrong direction.
 - III. **Reduced System Efficiency:** The system may experience energy inefficiencies due to power being lost as heat when reverse current flows through the panel, reducing the overall performance of the photovoltaic system.

4.15 Experiment-15 Direct Load Connection to Photovoltaic Panels

Modules required for the experiment;

- Light Angle Adjustable Solar Panel,
- Monophase Switching Module,
- Energy Distribution Module,
- PC Interface Module, (Optional)
- Light Source Control Module (LSC),
- AC/DC Measurement Module (MM),
- Lamb Module (12V DC),

Experiment Connection;

1. Firstly, connect the energy input to the Energy Distribution Module using a Banana Jack cables for safety reasons.
2. Subsequently, connect the Energy Distribution Module using Banana Jack cables.
3. Next, connect the power input for the Light Source Control module and the lamps of the PV panel to the industrial socket located on the module with the Banana Jack cables.
4. Connect the PV panels in parallel to each other.
5. To view the measurement values, make the power connections of the Digital AC/DC Measurement Module.
6. Connect the voltmeter on the module in parallel with the load.
7. Then connect an ammeter between the panel and the load to see the current drawn by the load.
8. If you would like to view the measured data and control your light source via computer, make the power connection of the PC Interface Module and connect the AC/DC Measurement Module and Light Source Control Module to the PC Interface Module with CAT6 cable.

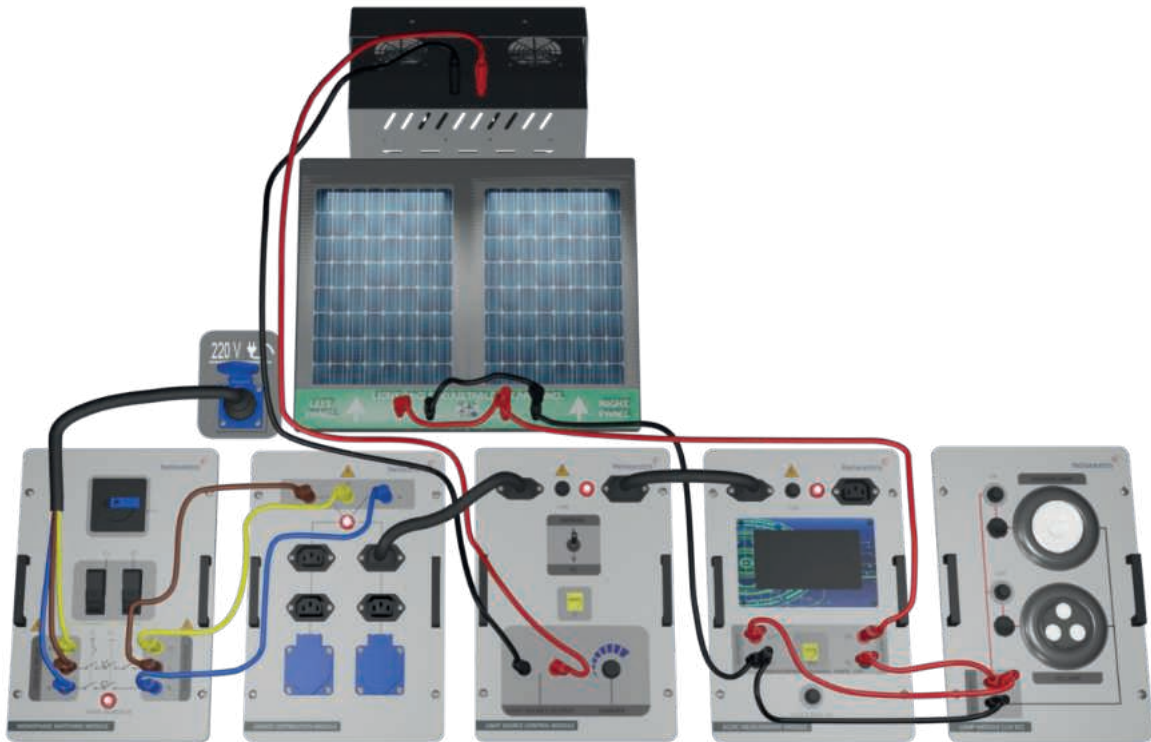

Figure-64. Installation Image of Direct Load Connection to Photovoltaic Panels

Stages of the Experiment;

1. Set up the connection as specified in Figure-64. Ensure a constant level of light in the laboratory by creating an average scenario. Any alterations to the positions of the lamps or curtains will have an impact on the experimental outcomes.
2. Align the angle of incidence of light to the photovoltaic panel to 90° (summer season) and the panel surface to be parallel to the ground. To achieve this, make the necessary adjustments by pulling the pins on the module and placing them in their correct positions. Set the potentiometer to the highest level on the LSC module.
3. Use the ammeter (I1) to measure the current transferred from the panel to the load. Accordingly, switch the Led lamp switch on the lamp module to the "on" position when the LSC Module is at the minimum light level. (The halogen lamp switch should be in the "off" position.) In this case, the LED will emit a weak light depending on the light level in the laboratory.
4. Record the values of the voltmeter (V1) and ammeter (I1) in the MM module in Table-50.

Minimum Amount of Light (Led Lamp)		Maximum Amount of Light (Led lamp)	
$I_1(\text{mA})$	$V_1(\text{V})$	$I_2(\text{mA})$	$V_2(\text{V})$
1	8,1	97	10,71

Table-50

- Gradually increase the light intensity with the DIMMER potentiometer on the LSC module until the V1 voltage reaches 12 volts. (V1 voltage above 12 volts may damage the LED!)
- Record the values of the voltmeter (V2) and ammeter (I2) in the MM module in Table-50 (at maximum light intensity).
- Set the halogen lamp switch on the lamp module to the "on" position and switch on the halogen lamp as a load. Record the values indicated by the voltmeter (V1) and ammeter (I1) on the MM module in Table-51 (maximum light intensity).

Maximum Amount of Light (Halogen Lamp)		Isc
$I_1(\text{mA})$	$V_1(\text{V})$	$I_2(\text{mA})$
106	0,04	2

Table-51

- In this case, please note that the lamps are not illuminated, but a current close to short-circuit current is drawn from the panel.

Research Questions about the Experiment;

- Explore the consequences of using an extremely low load resistance on the panel's output voltage and current.
- Share your perspective on the suitability of connecting the panel output directly to the load as a working method.

Answers to the Research Questions;

1. When an extremely low load resistance is applied to the output of a photovoltaic panel, the current increases significantly because the low resistance allows more current to flow through the circuit. However, this increased current flow can cause the output voltage of the panel to drop sharply. This is due to the internal resistance of the photovoltaic cells and the fact that the panel is not able to maintain both high current and high voltage simultaneously under such conditions. Consequently, the power output of the panel might also drop because the product of voltage and current ($P = I * V$) will no longer be optimized. The panel operates more efficiently with a balanced load, where both voltage and current are at moderate levels, maximizing power output.
2. Connecting the panel output directly to the load is generally not recommended. There are several reasons for this:
 - a. **Voltage Drop:** If the load resistance is too low, the output voltage of the panel will drop, which can prevent devices from operating properly.
 - b. **Overcurrent:** If the load exceeds the panel's capacity, it will draw excessive current. This can lead to panel damage or overheating.
 - c. **Efficiency Loss:** Direct connection may cause the panel to operate away from its optimal working point, leading to reduced energy efficiency.
 - d. **Safety Issues:** Overloading poses a short-circuit risk, which can result in safety hazards.

For these reasons, it's better to use a regulator or MPPT (Maximum Power Point Tracking) controller between the panel and the load to ensure safe and efficient operation

4.16 Experiment-16 No-Load Commissioning of Off-Grid Inverter

Modules required for the experiment;

- Light Angle Adjustable Solar Panel,
- Monophase Switching Module,
- Energy Distribution Module,
- PC Interface Module, (Optional)
- Light Source Control Module (LSC),
- Off-Grid Inverter Module,
- Solar Charge Regulator Module,
- Isolated Measurement Module,
- Accumulator Module,

Experiment Connection;

1. Begin by connecting the energy input to the Energy Distribution Module using a Banana Jack cables for safety.
2. Use Banana Jack cables to connect the Energy Distribution Module.
3. Connect the power input of the Light Source Control module to the lamps of the PV panel using the provided Banana Jack cables.
4. Connect the PV panels in parallel to each other.
5. Connect the output terminals from the panels to the PV panel-shaped part of the Solar Charge Regulator Module.
6. Attach the Accumulator Module and the Off-Grid Inverter Module to the terminals of the Solar Charge Regulator with the Battery-shaped connectors.
7. Connect the output of the Off-Grid Inverter Module to the inputs of the Isolated Measurement Module.
8. Connect the measurement end of your oscilloscope to the BNC terminal of the Isolated Measurement Module using a BNC-to-BNC cable.

- If you would like to control your light source via computer, make the power connection of the PC Interface Module and Light Source Control Module to the PC Interface Module with CAT6 cable.

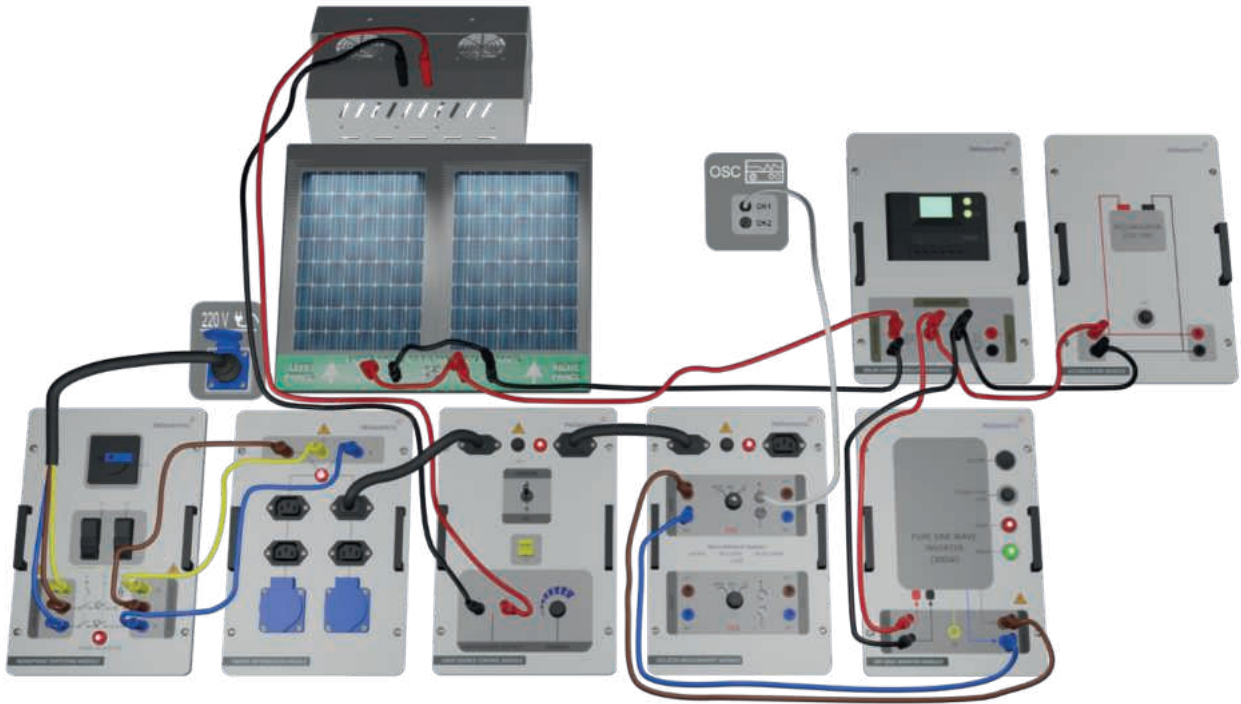
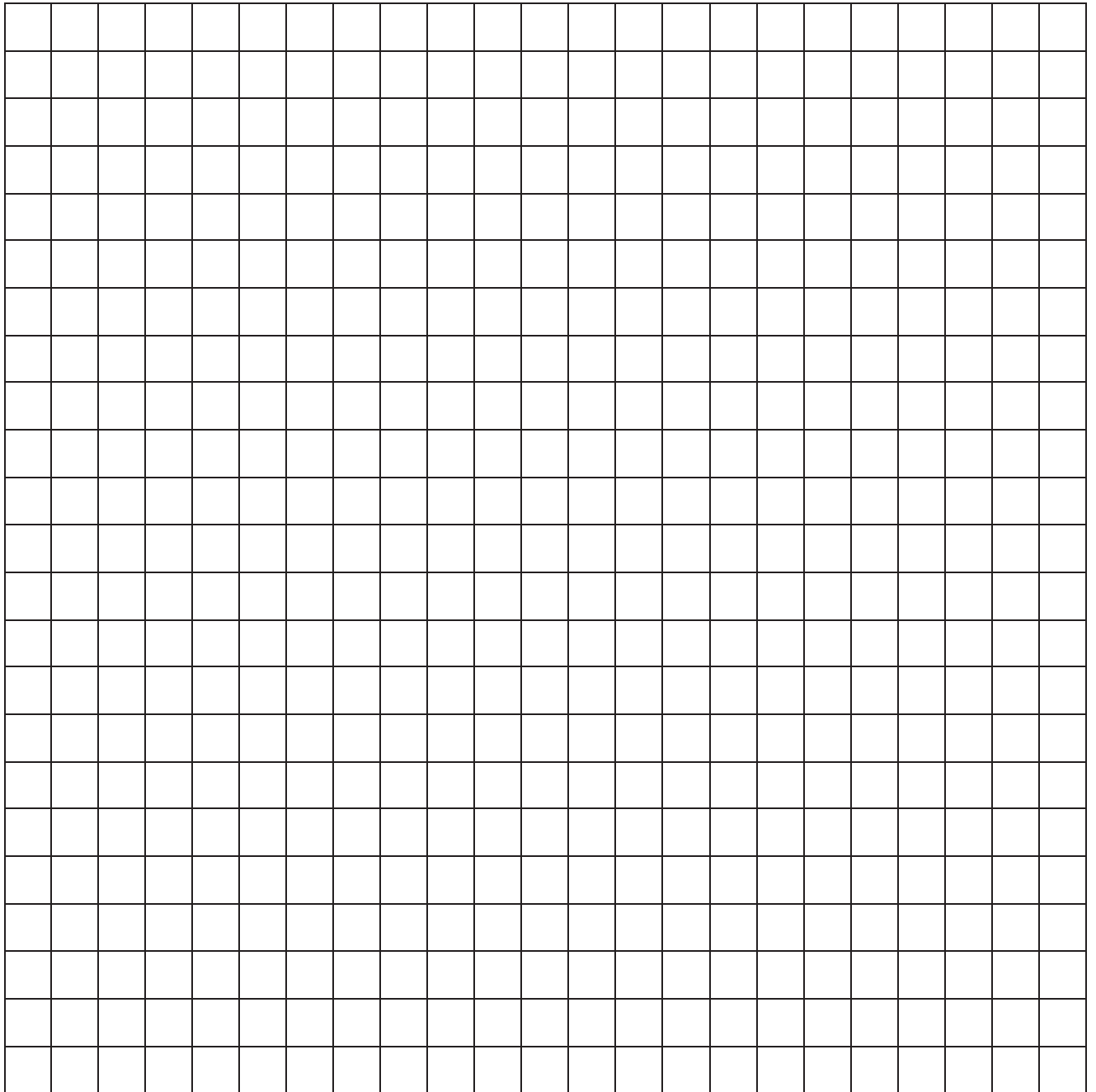

Figure-65. Installation Image of No-Load Commissioning of Off-Grid Inverter

Stages of the Experiment;

- Set up the connection as specified in Figure-65. Ensure a constant level of light in the laboratory by creating an average scenario. Any alterations to the positions of the lamps or curtains will have an impact on the experimental outcomes.
- Align the angle of incidence of light to the photovoltaic panel to 90° (summer season) and ensure that the panel surface is parallel to the ground. To achieve this, make the necessary adjustments by pulling the pins on the module and placing them in their correct positions. Set the potentiometer to the highest level on the LSC module.
- Turn on the Off-Grid Inverter power switch. Two LEDs, one red and one green, are located next to the power switch. The red LED signals a low battery voltage with an audible warning, while the green LED indicates that the battery is charged to the appropriate level and that the output voltage is being generated.

4. The LED next to the power button on the Off-Grid Inverter module should illuminate green. If the red LED is illuminated and an audible warning is emitted, it indicates that the battery is not sufficiently charged. In this situation, the battery must be charged.
5. Set the commutator on the Isolated Measurement Module to X0.01. This will isolate and attenuate the inverter output signal by a factor of 1:100.
6. Analyse the shape of the signal for the inverter output voltage using the Isolated Measurement Module. Draw the signal shape in the space provided in Graph-1. Record the peak-to-peak (V_{pp}), effective (V_{rms}) and frequency of the inverter output voltage in the space provided below the graph. (Multiply the measurements made with the oscilloscope by 100 considering the attenuation of 1:100. Make sure that the probe attenuation is at X1 position.)



Graph-1

4.17 Experiment-17 Installation of a Basic Photovoltaic System with DC Load

Modules required for the experiment;

- Light Angle Adjustable Solar Panel,
- Monophase Switching Module,
- Energy Distribution Module,
- PC Interface Module, (Optional)
- Light Source Control Module (LSC),
- AC/DC Measurement Module (MM),
- Solar Charge Regulator Module,
- Accumulator Module,
- Analog Measurement Module,
- Lamp Module (12V DC),

Experiment Connection;

1. Begin by connecting the energy input to the Energy Distribution Module using a Banana Jack cables for safety reasons.
2. Next, establish connections to the Energy Distribution Module using Banana Jack cables.
3. Connect the power input for the Light Source Control module and the lamps of the PV panel to the industrial socket located on the module using the Banana Jack cables.
4. Connect the PV panels in parallel to each other.
5. Connect the output terminal from the panels to the PV panel-shaped part of the Solar Charge Regulator Module.
6. Insert the ammeter of the Analog Measurement Module between the PV panels and the Solar Charge Regulator module.
7. Connect the inputs of the Solar Charge Regulator, shaped like a battery, to the Accumulator Module.
8. Attach the ammeter of the AC/DC Measurement Module between them.

9. Finally, connect the 12V Lamp Module to the load part of the Solar Charge Regulator to complete the experiment.
10. If you would like to view the measured data and control your light source via computer, make the power connection of the PC Interface Module and connect the AC/DC Measurement Module and Light Source Control Module to the PC Interface Module with CAT6 cable.

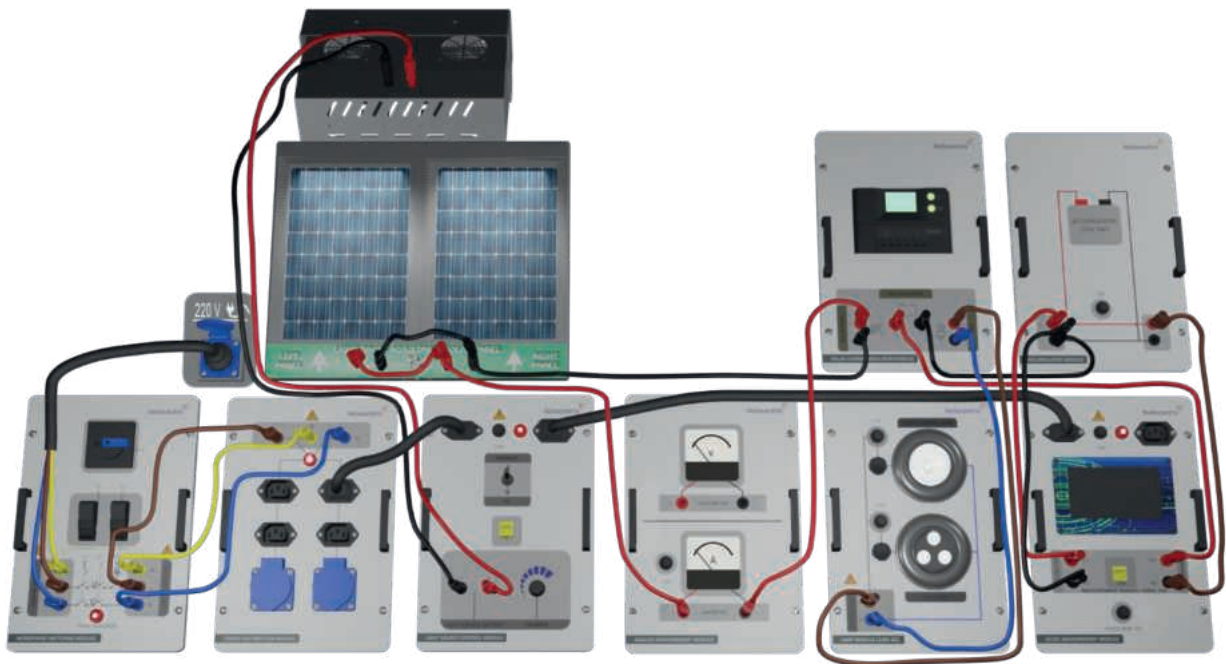

Figure-66. Installation Image of Installation of a Basic Photovoltaic System with DC Load

Stages of the Experiment;

1. Set up the connection as specified in Figure-66. Ensure a constant level of light in the laboratory to maintain an average scenario. Note that any changes to the positions of the lamps or curtains may affect the experimental outcomes.
2. Align the angle of incidence of light to the photovoltaic panel at 90° (summer season) and ensure that the panel surface is parallel to the ground. To achieve this, make the necessary adjustments by pulling the pins on the module and placing them in their correct positions. Set the potentiometer to the highest level on the LSC module.
3. Pay close attention to the data provided on the Solar Charge Regulator Module.

4. Use the ammeter (I_b) in the MM module to measure the current flowing to or from the battery. Additionally, use the analog ammeter (I_p) to measure the current drawn from the photovoltaic panel. Record the values displayed by the ammeters in Table-52 under the following conditions: minimum light level and with both switches on the Lamp Module turned off (no load).
5. Record the battery voltage measurement using the voltmeter (V_b) in the MM module in Table-52.

Minimum Light Amount (No Load)			Maximum Light Amount (No Load)		
I_b (mA)	I_p (mA)	V_b (V)	I_b (mA)	V_p (V)	V_b (V)
0	1mA	12,10	110mA	110mA	21,11

Table-52

6. Adjust the light intensity to its maximum setting using the DIMMER potentiometer located on the LSC module. Record the readings for the ammeter and voltmeter in Table-52.
7. Afterward, reduce the light intensity to the minimum level by adjusting the potentiometer on the LSC module.
8. Turn on the LED lamp by activating the lamp switch.
9. Record the values of I_b , I_p , and V_b in Table-53.
10. Measure the battery voltage with the voltmeter (V_b) on the MM module and record it in Table-53.
11. Increase the light intensity to the maximum level using the potentiometer on the LSC module.
12. Record the values displayed by the ammeters and voltmeter in Table-53.

Minimum Light Amount (LED Lamp)			Maximum Light Amount (LED Lamp)		
$I_b(\text{mA})$	$I_p(\text{mA})$	$V_b(\text{V})$	$I_b(\text{mA})$	$V_p(\text{V})$	$V_b(\text{V})$
60mA	112mA	12,10	150mA	1mA	12,01

Table-53

13. Turn on the Halogen Lamp switch on the Lamp Module to activate the halogen lamp as a load.
14. Record the values displayed by the ammeters and voltmeter in Table-54.
15. Note that as the halogen lamp draws a high current, the battery charge bars in the Solar Charge Regulator module may start to decrease over time. Once the charge level reaches a certain point, the load will be automatically disabled to prevent the battery from discharging completely. This will be indicated by a flashing battery symbol.

Maximum Light Amount (Halogen Lamp)		
$I_b(\text{mA})$	$I_p(\text{mA})$	$V_b(\text{V})$
5000mA	111mA	11,71

Table-54

4.18 Experiment-18 Installation of a Basic Photovoltaic System with AC Load

Modules required for the experiment;

- Light Angle Adjustable Solar Panel,
- Monophase Switching Module,
- Energy Distribution Module,
- PC Interface Module, (Optional)
- Light Source Control Module (LSC),
- AC/DC Measurement Module (MM),
- Off-Grid Inverter Module,
- Solar Charge Regulator Module,
- Accumulator Module,
- Analog Measurement Module,
- Isolated Measurement Module,
- Lamp Module (220VAC),

Experiment Connection;

1. Firstly, connect the energy input to the Energy Distribution Module using a Banana Jack cables for safety reasons.
2. Subsequently, connect the Energy Distribution Module using Banana Jack cables.
3. Connect the power input for the Light Source Control module and the lamps of the PV panel to the industrial socket located on the module with the Banana Jack cables.
4. Connect the PV panels in parallel.
5. Connect the output terminal from the panels to the PV panel-shaped part of the Solar Charge Regulator Module. Insert the ammeter of the Analog Measurement Module between the PV panels and the Solar Charge Regulator Module.
6. Connect the Solar Charge Regulator's Battery-shaped inputs to the Accumulator Module.
7. Connect the AC/DC Measurement Module's ammeter between them.

8. Connect the voltmeter of the Digital AC/DC Measurement Module to the Accumulator Module and connect the Off-Grid Inverter Module to the terminals of the Solar Charge Regulator with the Battery-shaped terminal.
9. Next, connect the output of the Off-Grid Inverter Module to the Isolated Measurement Module inputs.
10. Connect the measurement end of your oscilloscope to the BNC terminal of the Isolated Measurement Module with a BNC to BNC cable.
11. Connect the Lamp Module (220V AC) to the load section of the Isolated Measurement Module to complete the installation of the experiment.
12. If you would like to view the measured data and control your light source via computer, make the power connection of the PC Interface Module and connect the AC/DC Measurement Module and Light Source Control Module to the PC Interface Module with CAT6 cable.

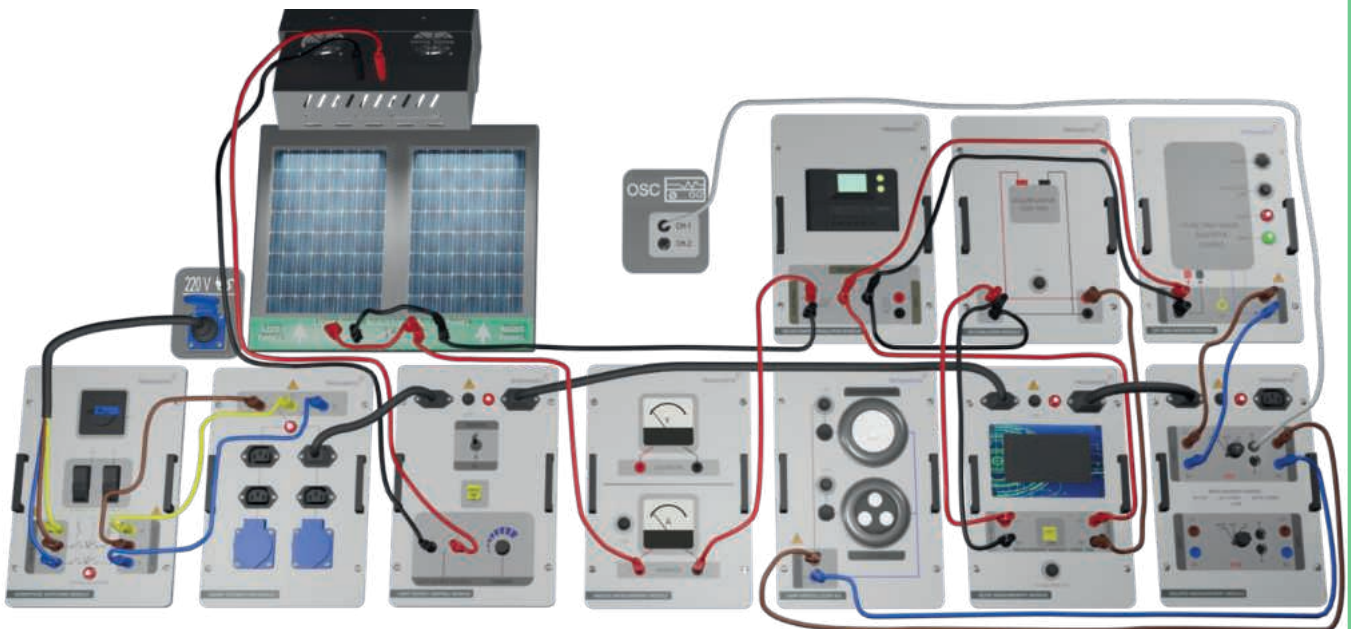
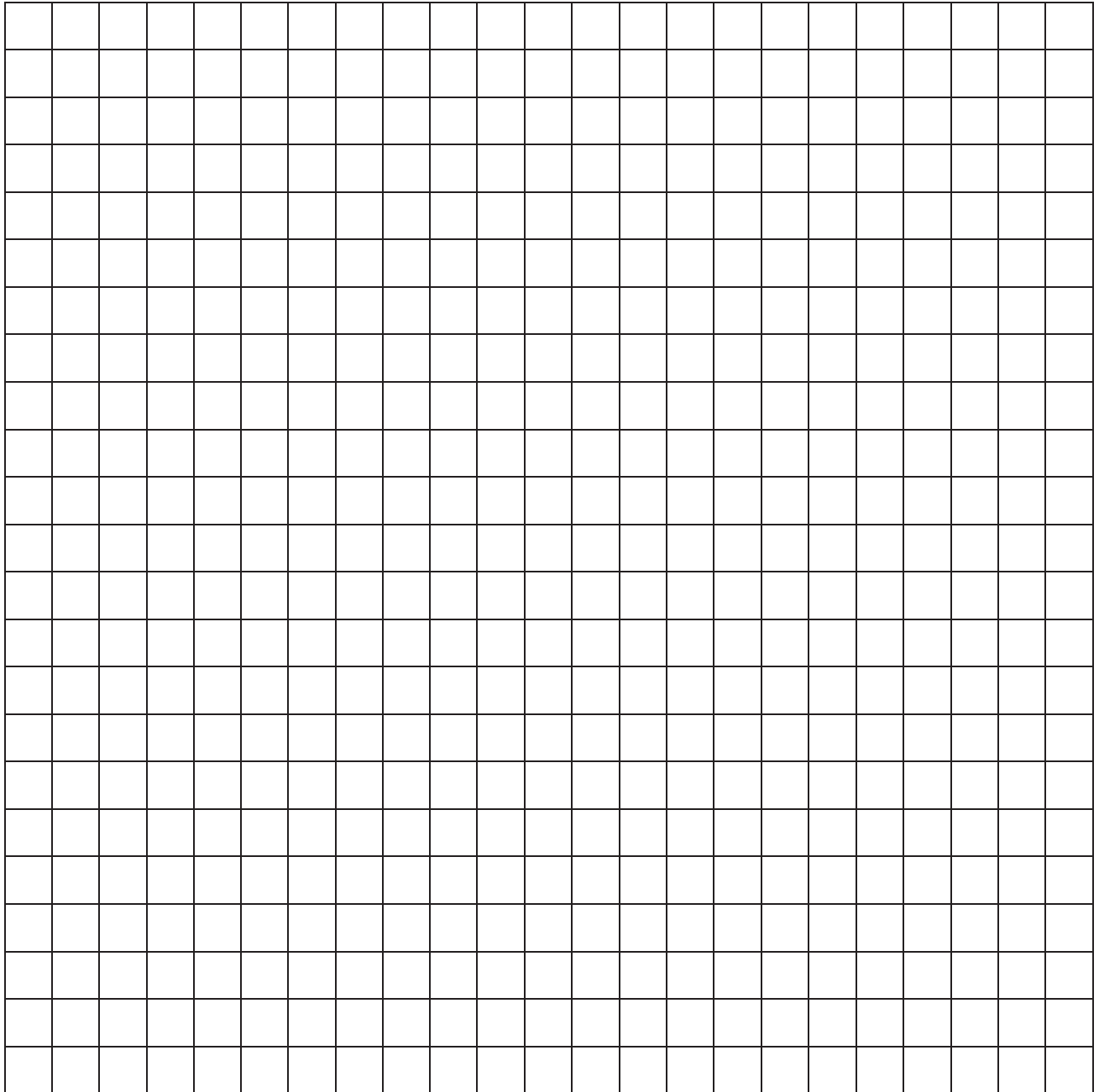

Figure-67. Installation Image of Installation of a Basic Photovoltaic System with AC Load

Stages of the Experiment;

1. Set up the connection as specified in Figure-67. Create an average lighting scenario in the laboratory to ensure a constant level of light. Be aware that any changes in the positions of lamps or curtains will impact the experimental outcomes.
2. Align the angle of incidence of light to the photovoltaic panel at 90° , simulating summer season conditions. The panel surface should be parallel to the ground. Adjust by pulling the pins on the module and placing them in the correct positions. Set the potentiometer to the highest level on the Light Source Control (LSC) module.
3. Turn on the Off-Grid Inverter power switch. Observe the two LEDs next to the switch: the red LED indicates a low battery voltage with an audible warning, while the green LED shows that the battery is charged to the appropriate level and that the output voltage is being generated.
4. Ensure the LED next to the power button on the Off-Grid Inverter module illuminates green. If the red LED illuminates and an audible warning is emitted, it indicates that the battery is not sufficiently charged and needs to be charged.
5. Set the commutator on the Isolated Measurement Module to X0.01 to isolate and attenuate the inverter output signal by a factor of 1:100.
6. Once the green LED adjacent to the power button on the Off-Grid Inverter module illuminates, draw the signal shape visible on the oscilloscope screen in the designated area of Graph 1. Record the V_{pp} , V_{rms} , and frequency values of the signal.



Graph-1

7. To activate the LED lamp, switch on the Lamp Module (220V AC) and load the system. Observe the changes in the output signal shape. If the LED lamp remains activated for an extended period, the inverter will cut the output power and emit an audible warning, depending on the battery's state.
8. To activate the energy-saving lamp, switch on the Lamp Module (220V AC) and load the system. Observe the changes in the output signal shape. Note that if the lamp remains activated for an extended period, the inverter will cut the output power and emit an audible warning, depending on the battery's state.

4.19 Experiment-19 Examination of Off-Grid Inverter Output Signal with DAQ Module

Modules required for the experiment;

- Light Angle Adjustable Solar Panel,
- Monophase Switching Module,
- Energy Distribution Module,
- PC Interface Module, (Optional)
- Light Source Control Module (LSC),
- AC/DC Measurement Module (MM),
- Off-Grid Inverter Module,
- Solar Charge Regulator Module,
- Accumulator Module,
- Analog Measurement Module,
- Isolated Measurement Module,
- Lamp Module (220VAC),
- Data Acquisition Module,

Experiment Connection;

1. Connect the energy input to the Energy Distribution Module using a Banana Jack cables for safety reasons.
2. Then, connect the Energy Distribution Module using Banana Jack cables.
3. Connect the power input for the Light Source Control module and the lamps of the PV panel to the industrial socket on the module with the Banana Jack cables.
4. Connect the PV panels in parallel to each other.
5. Connect the output terminal from the panels to the PV panel-shaped part of the Solar Charge Regulator Module.
6. Connect the Solar Charge Regulator's Battery-shaped inputs to the Accumulator Module.
7. Place the AC/DC Measurement Module's ammeter between the Solar Charge Regulator and the Accumulator Module.

8. Connect the voltmeter of the Digital AC/DC Measurement Module to the Accumulator Module and the Off-Grid Inverter Module to the terminals of the Solar Charge Regulator's Battery-shaped input.
9. Connect the output of the Off-Grid Inverter Module to the inputs of the Isolated Measurement Module.
10. Finally, connect any analog input terminal of the Data Acquisition Module to the BNC terminal of the Isolated Measurement Module using a BNC to Banana Jack cable.
11. Connect the Lamp Module (220V AC) to the load section of the Isolated Measurement Module to complete the experiment setup.
12. If you would like to view the measured data and control your light source via computer, make the power connection of the PC Interface Module and connect the AC/DC Measurement Module and Light Source Control Module to the PC Interface Module with CAT6 cable.

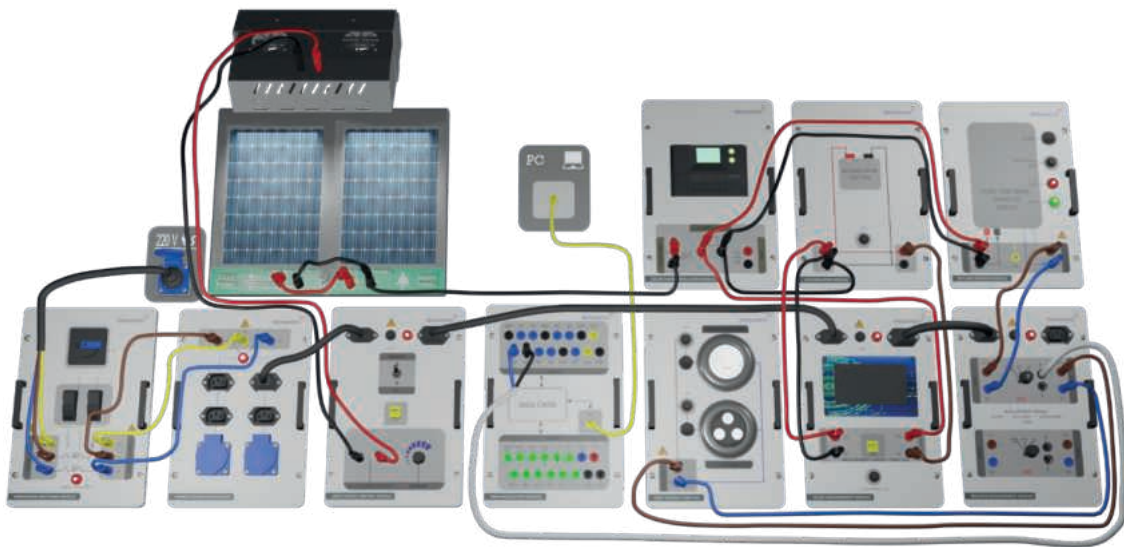

Figure-68. Installation Image of Examination of Off-Grid Inverter Output Signal with DAQ Module

Stages of the Experiment;

1. Set up the connection as specified in Figure-68. Ensure a constant level of light in the laboratory by creating an average scenario. Be aware that any changes in the positions of lamps or curtains will impact the experimental outcomes.

2. Align the angle of incidence of light to the photovoltaic panel at 90° , representative of summer season conditions. The panel surface should be parallel to the ground. Make the necessary adjustments by pulling the pins on the module and placing them in their correct positions. Set the potentiometer to the highest level on the Light Source Control (LSC) module.
3. Make the USB connection between the Data Acquisition Module and the computer.
4. Open the DAQ Express application on the PC.
5. Turn on the power switch located on the Off-Grid Inverter module.
6. Observe the two LEDs next to the power switch: one red and one green. The red LED indicates a low battery voltage with an audible warning, while the green LED signifies that the battery is charged to the appropriate level and that the output voltage is being generated.
7. Ensure the LED next to the power button on the Off-Grid Inverter module illuminates green. If the red LED illuminates and an audible warning is emitted, it indicates that the battery is not sufficiently charged and needs to be charged.
8. Analyze the signal by adjusting the settings through DAQ Express.



Picture-1

9. Click the 'Save' button in DAQ Express to save the signal and analyze it in detail.

4.20 Experiment-20 Examination of Measurement of Off-Grid Inverter Output Signal with Energy Analyser

Modules required for the experiment;

- Light Angle Adjustable Solar Panel,
- Monophase Switching Module,
- Energy Distribution Module,
- PC Interface Module, (Optional)
- Light Source Control Module (LSC),
- Off-Grid InvertOr Module,
- Solar Charge Regulator Module,
- AC Energy Analyser Module (AE),
- Lamp Module (220V AC),

Experiment Connection;

1. Firstly, connect the energy input to the Energy Distribution Module using a Banana Jack cables for safety reasons.
2. Then, connect the Energy Distribution Module using Banana Jack cables.
3. Next, connect the power input for the Light Source Control module and the lamps of the PV panel to the industrial socket on the module with the Banana Jack cables.
4. Connect the PV panels in parallel.
5. Connect the output terminal from the panels to the PV panel-shaped part of the Solar Charge Regulator Module.
6. Connect the Off-Grid Inverter Module to the inputs with battery-shaped connectors.
7. Connect the output of the Off-Grid Inverter Module to the inputs of the AC Energy Analyzer Module.
8. Then, connect the outputs of the AC Energy Analyzer Module to the input terminals of the Lamp Module (220V).
9. Complete the installation of the experiment.

10. If you would like to view the measured data and control your light source via computer, make the power connection of the PC Interface Module and connect the AC Energy Analyser Module and Light Source Control Module to the PC Interface Module with CAT6 cable.

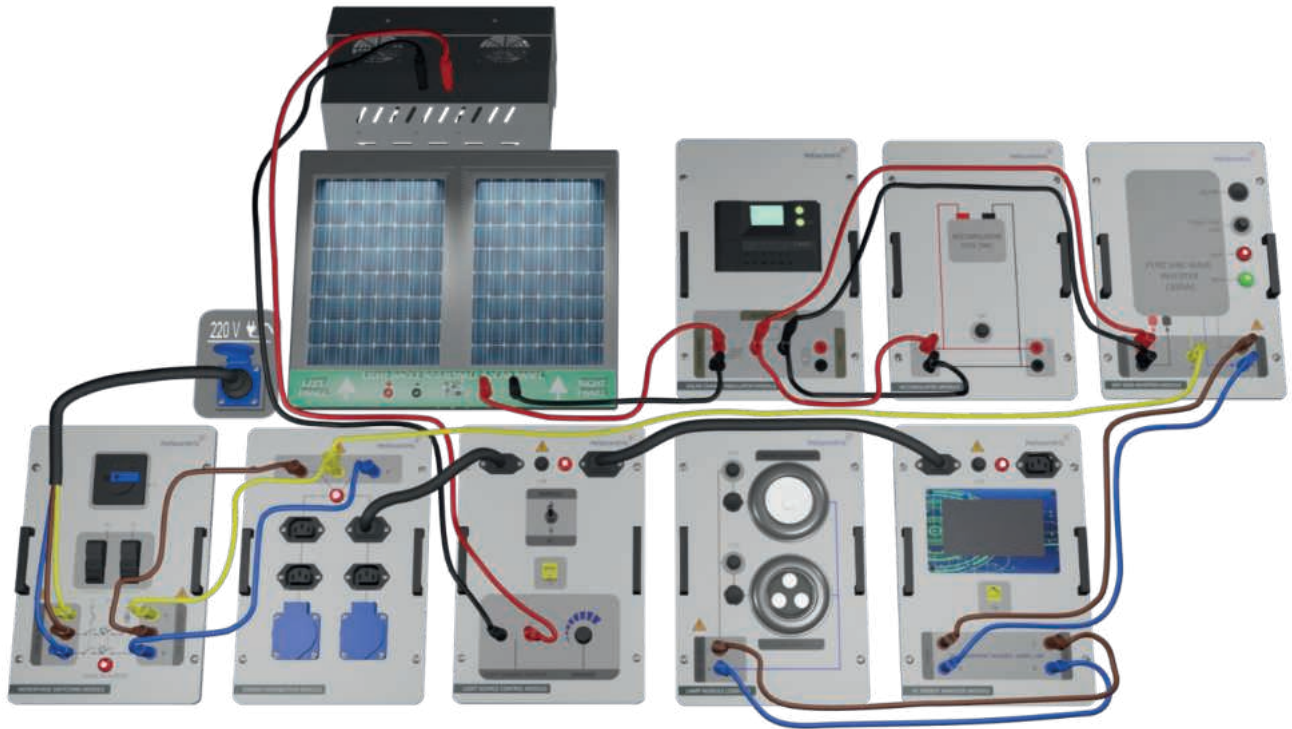

Figure-69. Installation Image of Examination of Measurement of Off-Grid Inverter Output Signal with Energy Analyser

Stages of the Experiment;

1. Set up the connection as specified in Figure-69. Maintain a constant level of light in the laboratory by creating an average lighting scenario. Note that any changes to the positions of lamps or curtains will affect the experimental results.
2. Align the angle of incidence of light to the photovoltaic panel at 90° , representing summer season conditions. Ensure the panel surface is parallel to the ground. Make the necessary adjustments by pulling the pins on the module and placing them in the correct positions. Set the potentiometer to the highest level on the Light Source Control (LSC) module.
3. Turn on the power switch of the Off-Grid Inverter module. Observe the two LEDs next to the switch: one red and one green. The red LED indicates low battery voltage with

an audible warning, while the green LED shows that the battery is adequately charged and output voltage is being generated.

4. Check the LED indicator next to the power button on the Off-Grid Inverter module. It should illuminate green. If the red LED lights up and an audible warning is emitted, it indicates that the battery is not sufficiently charged and needs to be charged.
5. Turn on the LED Lamp and Energy Saving Lamp switches on the Lamp Module (220V) and load the system.
6. Record the inverter's output voltage (V), current (I), apparent power (VA), power (W), and power factor ($\text{Cos}\phi$) from the AC Energy Analyzer Module in Table-55.
7. Analyze the parameters measured using the AC Energy Analyzer.

AC Energy Analyser				
Voltage	Current	Power	A.Power	$\text{Cos}\phi$
230V	0,17A	22W		

Table-55

8. Examine the parameters that were measured using the AC Energy analyser.

4.21 Experiment-21 Measurement of Energy Received from Off-Grid Inverter

Modules required for the experiment;

- Light Angle Adjustable Solar Panel,
- Monophase Switching Module,
- Energy Distribution Module,
- PC Interface Module, (Optional)
- Light Source Control Module (LSC),
- Off-Grid InvertOr Module,
- Solar Charge Regulator Module,
- AC Energy Analyser Module (AE),
- Lamp Module (220V AC),
- Electronic Electricity Meter Module

Experiment Connection;

1. Firstly, connect the energy input to the Energy Distribution Module using a Banana Jack cables for safety reasons.
2. Subsequently, connect the Energy Distribution Module using Banana Jack cables.
3. Next, connect the power input for the Light Source Control module and the lamps of the PV panel to the industrial socket on the module with the Banana Jack cables.
4. Connect the PV panels in parallel.
5. Connect the output terminal from the panels to the PV panel-shaped part of the Solar Charge Regulator Module.
6. Connect the Off-Grid Inverter Module to the inputs with battery-shaped connectors.
7. Connect the output of the Off-Grid Inverter Module to the inputs of the Electronic Electricity Meter Module.
8. Then, connect the outputs of the Electronic Electricity Meter Module to the input terminals of the AC Energy Analyzer Module.

9. Connect the outputs of the AC Energy Analyzer Module to the input terminals of the Lamp Module (220V).
10. Complete the installation of the experiment.
11. If you would like to view the measured data and control your light source via computer, make the power connection of the PC Interface Module and connect the AC Energy Analyser Module and Light Source Control Module to the PC Interface Module with CAT6 cable.

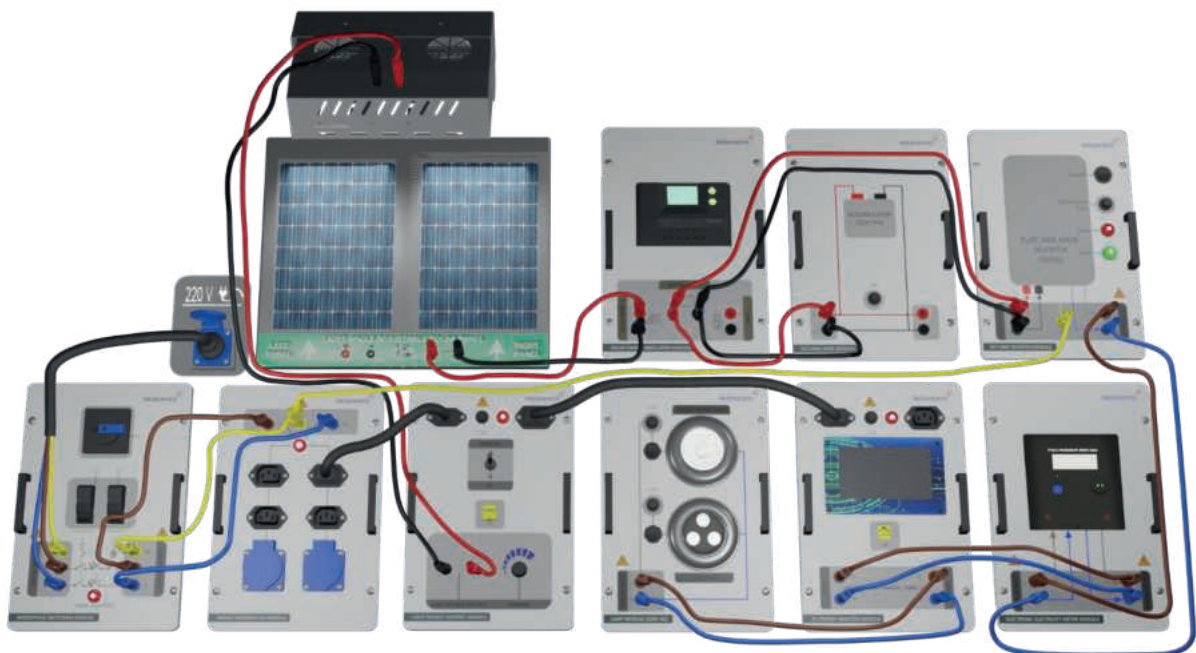

Figure-70. Installation Image of Measurement of Energy Received from Off-Grid Inverter

Stages of the Experiment;

1. Set up the connection as specified in Figure-70. Maintain a constant level of light in the laboratory by creating an average lighting scenario. Be aware that any changes to the positions of lamps or curtains will affect the experimental outcomes.
2. Align the angle of incidence of light to the photovoltaic panel at 90° , representative of summer season conditions. Ensure the panel surface is parallel to the ground. Adjust by pulling the pins on the module and placing them in the correct positions. Set the potentiometer to the highest level on the Light Source Control (LSC) module.

3. Turn on the power switch of the Off-Grid Inverter module. Observe the two LEDs next to the switch: one red and one green. The red LED indicates low battery voltage with an audible warning, while the green LED shows that the battery is charged to the appropriate level and output voltage is being generated.
4. Check the LED indicator next to the power button on the Off-Grid Inverter module. It should illuminate green. If the red LED illuminates and an audible warning is emitted, it indicates that the battery is not sufficiently charged and needs to be charged.
5. Turn on both switches on the Lamp Module (220V AC) to load the system.
6. Observe the energy consumption with the Electronic Electricity Meter Module. Note that as the total power of both lamps is 40W, their energy consumption for one hour will be 40Wh. It may not be possible to observe a change in the counter under laboratory conditions due to the need for the system to run for a longer duration. However, energy measurement is a crucial issue, especially for industrial systems.

4.22 Experiment-22 Examination of On-Grid Invertor

Modules required for the experiment;

- Light Angle Adjustable Solar Panel,
- Monophase Switching Module,
- Energy Distribution Module,
- PC Interface Module, (Optional)
- Light Source Control Module (LSC),
- Accumulator Module,
- AC/DC Measurement Module (MM),
- On-Grid Invertor Module,
- Solar Charge Regulator Module,

Experiment Connection;

1. Connect the energy input to the Energy Distribution Module using a Banana Jack cables for safety reasons.
2. Then, connect the Energy Distribution Module using Banana Jack cables.
3. Connect the power input for the Light Source Control module and the lamps of the PV panel to the industrial socket on the module with the Banana Jack cables.
4. Connect the PV panels in parallel.
5. Connect the output terminal from the panels to the PV panel-shaped part of the Solar Charge Regulator Module.
6. Connect the On-Grid Inverter Module and Accumulator Module to the battery-shaped inputs on the Solar Charge Regulator Module.
7. Connect the output of the On-Grid Inverter Module to the voltmeter of the Digital AC/DC Measurement Module.
8. Then, connect the system back to the grid from the Energy Distribution Module to complete the installation of the experiment.

- If you would like to view the measured data and control your light source via computer, make the power connection of the PC Interface Module and connect the AC/DC Measurement Module and Light Source Control Module to the PC Interface Module with CAT6 cable.

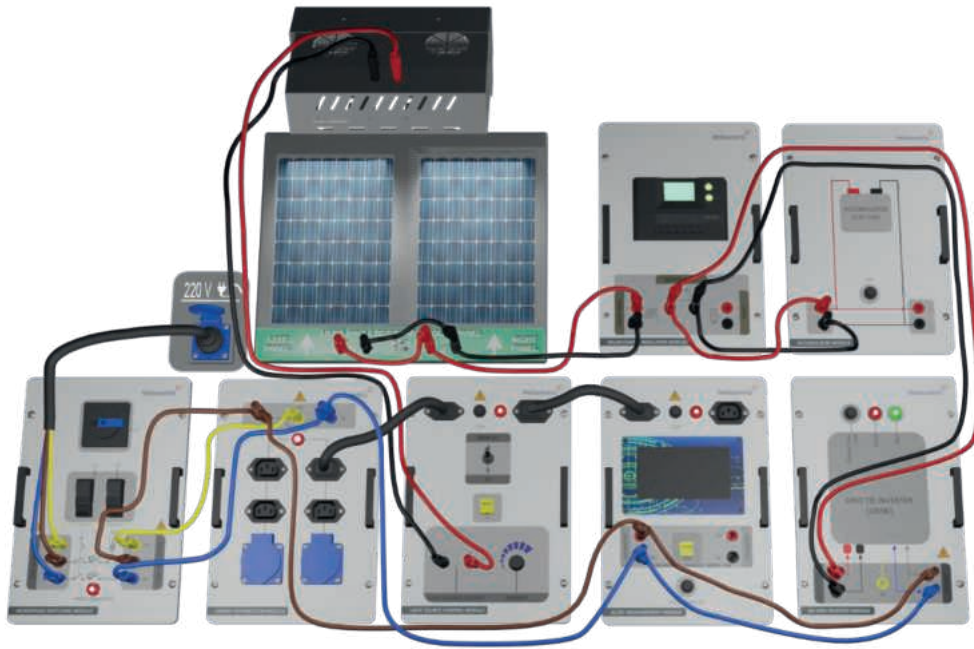

Figure-71. Installation Image of Examination of On-Grid Invertor

Stages of the Experiment;

- Set up the connection as specified in Figure-71. Maintain a constant level of light in the laboratory by creating an average lighting scenario. Be aware that any changes in the positions of lamps or curtains will impact the experimental results.
- Align the angle of incidence of light to the photovoltaic panel at 90° , representative of summer season conditions. Ensure the panel surface is parallel to the ground. Make the necessary adjustments by pulling the pins on the module and placing them in the correct positions. Set the potentiometer to the highest level on the Light Source Control (LSC) module.
- Examine the voltmeter output of the On-Grid Inverter module. It is important to note that the city grid is not connected to the system at this stage.

4. Disconnect the On-Grid inverter from the grid and verify its functionality. This step is crucial to understand the operational dynamics of the inverter when isolated from the grid.
5. Discuss the reason why an On-Grid inverter fails to operate when disconnected from the grid. This part of the experiment is essential for understanding the dependence of On-Grid inverters on grid connectivity for their operation.

5. Wind Energy Systems

Wind energy is produced by the movement of air masses in the atmosphere, driven by differences in temperature. When air is heated, it rises, creating a vacuum that cooler air rushes to fill, resulting in a continuous cycle. Approximately 1-2% of the solar energy received by the Earth is converted into wind energy in the atmosphere. The sun's consistent heating of the Earth's surface ensures the continuity of wind. Wind energy production does not require raw materials and is considered carbon neutral, as it does not emit pollutants or harm the environment.

The system that converts the kinetic energy obtained from the wind's movement into electrical energy is known as a wind turbine. Wind turbines are a widely used source of renewable energy for electricity generation. They function similarly to windmills. The wind rotates the blades, generating mechanical energy. This mechanical energy is then transferred to generators, which convert it into electricity. Wind turbines consist of various components that work together to enhance efficiency.

A typical wind turbine includes the following sections:

1. **Tower:** The structural support for the turbine.
2. **Blades:** Components that catch the wind, causing rotation.
3. **Nacelle:** Located at the top of the tower, housing generators, control units, and shafts.

The nacelle is a critical part of the turbine, containing the equipment necessary to convert the mechanical energy produced by the blades into electricity.

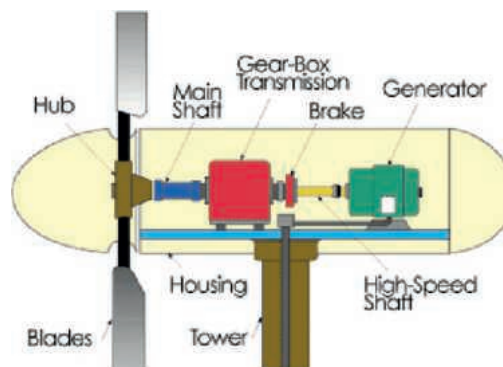

Figure-72. Internal Structure of a Wind Turbine

Although wind turbines operate on a simple principle, they can generate substantial amounts of electricity. The production capacity of modern wind turbines has reached the megawatt (MW) level, marking a significant advancement from the initial 20-30 kilowatt (KW) range of the first turbines. Horizontal axis wind turbines are generally preferred for electricity generation, though vertical and oblique axis types are also in use. The average lifespan of a wind turbine is about 25 years.

The working principle of wind turbines involves the rotation of blades due to the impact of moving air. This rotation converts the kinetic energy of the wind into mechanical energy in the rotor. This mechanical energy is then transferred to the generator. Inside the generator, electromagnetic induction is used to convert this mechanical energy into electrical energy. The generated electricity is then either stepped up in voltage by transformers, stored in batteries, or directly transmitted to the electrical grid or receivers.

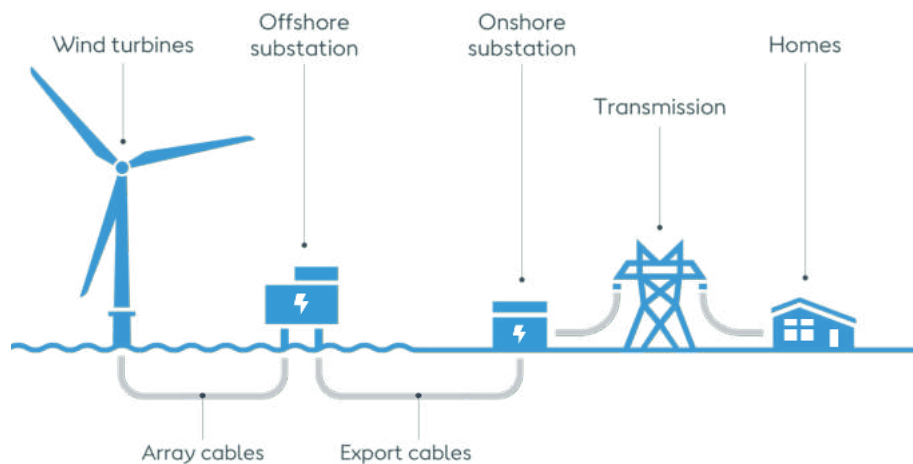

Figure-73. Working Principle of a Wind Turbine

6. Applications of Wind Energy Training Kit

6.1 Experiment-1 Examination of the Relation between Wind Speed and Turbine Operation

Modules required for the experiment;

- Wind Turbine Module
- Monophase Switching Module,
- Energy Distribution Module,
- PC Interface Module, (Optional)
- Wind Simulator Module (WS),
- AC/DC Measurement Module (MM),
- Isolated Measurement Module,

Experiment Connection;

1. Firstly, connect the energy input to the Energy Distribution Module using a Banana Jack cables for safety reasons.
2. Then, connect the Energy Distribution Module using Banana Jack cables.
3. Connect the power input for the Wind Simulator Module and the Banana Jack cables of the Wind Turbine to the Wind Simulator Module.
4. Connect two of the three-phase winding terminals of the wind turbine to the voltmeter part of the AC/DC Measurement Module.
5. Connect the voltmeter to the inputs of the Isolated Measurement Module.
6. Connect the measurement end of your oscilloscope to the BNC terminal of the Isolated Measurement Module with a BNC to BNC cable.
7. If you would like to view the measured data and control your wind speed via computer, make the power connection of the PC Interface Module and connect the AC/DC Measurement Module and Wind Simulator Module to the PC Interface Module with CAT6 cable.

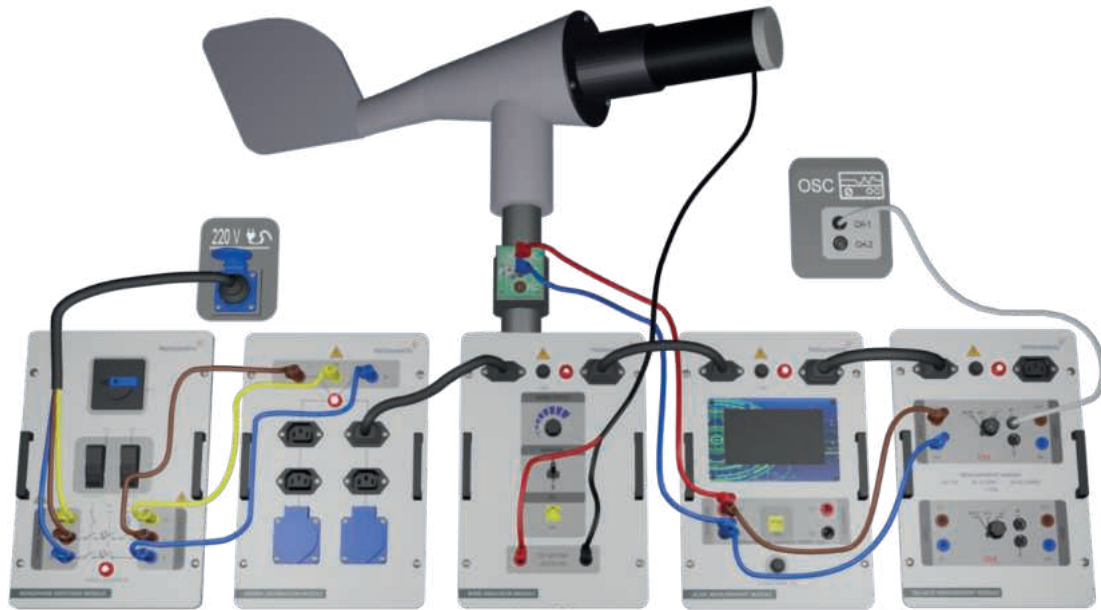

Figure-74. Installation Image of Examination of the Relation between Wind Speed and Turbine Operation

Stages of the Experiment;

1. Make the connection as illustrated in Figure-74. Lock the caster of the wind turbine to prevent any movement.
2. Set the Wind Simulator Module switch to MANUAL mode. Adjust the SPEED potentiometer to its minimum position.
3. Record the voltmeter reading in Table-56.
4. Gradually increase the wind speed using the SPEED potentiometer, setting it to level 1. Calculate the wind speed using the following formula:

$$n = \frac{60 \cdot f}{2P}$$

n = Rotating Speed (rpm)

f = Frequency (Hz)

2P = Number of Poles

Record the wind speed in Table-56 under "1. SPEED".

5. Continue to gradually increase the wind speed, this time setting the SPEED potentiometer to level 2. Record the new wind speed in Table-56 under "2. SPEED".

Speed	Min. Speed	1.Speed	2.Speed	3.Speed	4.Speed	5.Speed	6.Speed	7.Speed	Max. Speed
Voltage(V)	0	0	1,3	3,91	6,5	8,85	11,8	14,71	22,3
Frequency(Hz)	0	0	7	19,5	32,5	44	55,56	73	110

Table-56

1. Gradually increase the wind speed by adjusting the SPEED potentiometer to level 3. Record the wind speed in Table-56 under "3. SPEED".
2. Continue to increase the wind speed, setting the SPEED potentiometer to level 4. Record this wind speed in Table-56 under "4. SPEED".
3. Further increase the wind speed by adjusting the SPEED potentiometer to level 5. Record the wind speed in Table-56 under "5. SPEED".
4. Gradually increase the wind speed again, this time setting the SPEED potentiometer to level 6. Record the wind speed in Table-56 under "6. SPEED".
5. Increase the wind speed once more by setting the SPEED potentiometer to level 7. Record the wind speed in Table-56 under "7. SPEED".
6. Adjust the SPEED potentiometer to its maximum setting. Observe and note the output voltage.
7. In Graph-1, plot the graph showing the relationship between the generator's output voltage and the generator speed. This visual representation will help in analyzing how the output voltage changes with varying generator speeds.

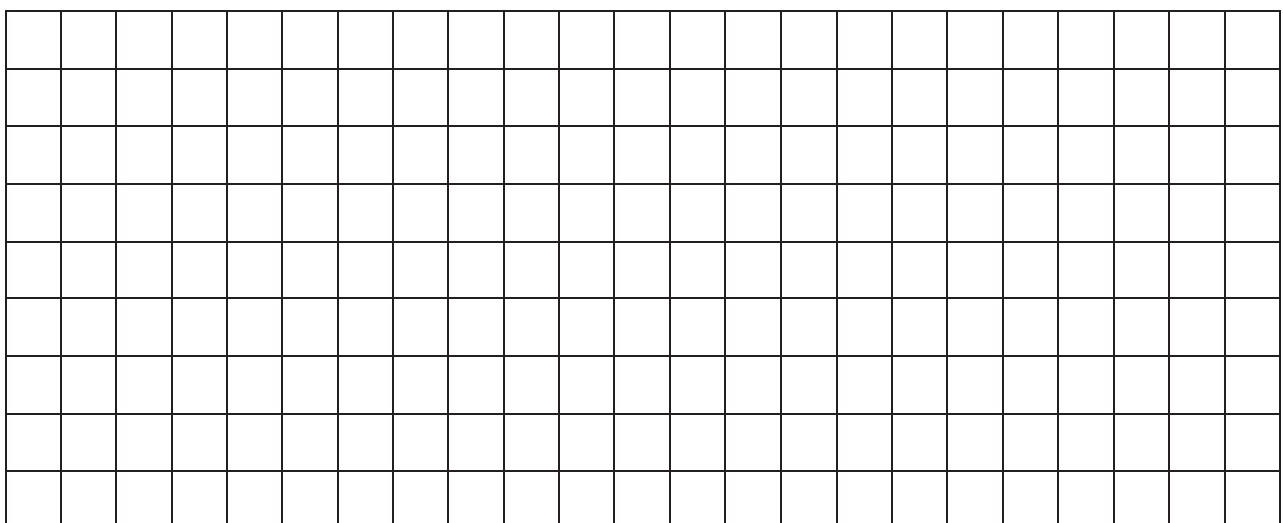

Graph-1

8. Set the commutator of channel CH1 on the Isolated Measurement Module to the X1 position and adjust the oscilloscope settings accordingly.
9. Gradually increase the wind speed by adjusting the SPEED potentiometer. Observe the changes in the output signal that occur as a result of this adjustment.
10. Set the SPEED potentiometer to a medium level. Capture and plot the signal on the oscilloscope as depicted in the provided reference. This will help in analyzing how the signal varies with different wind speeds

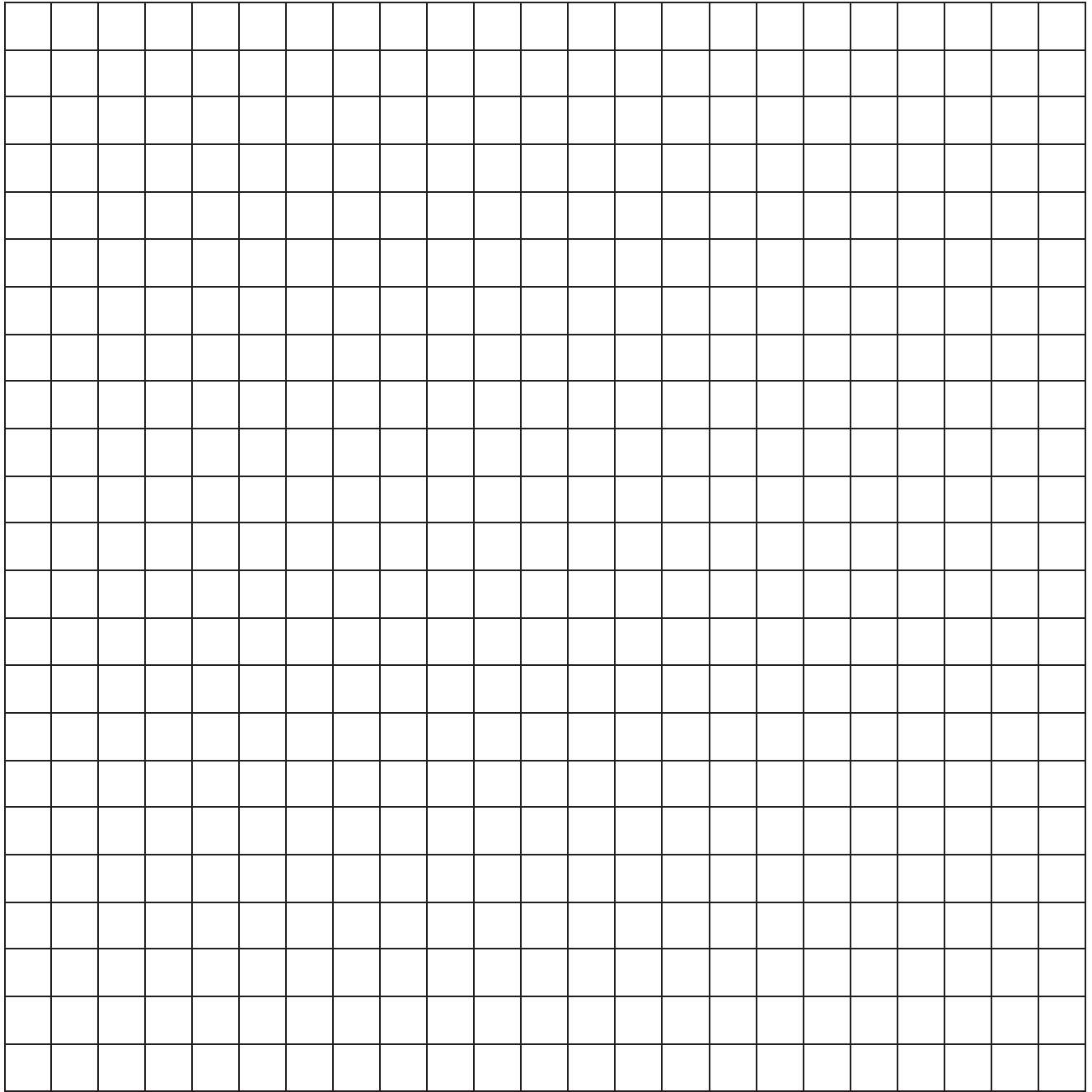

Graph-2

6.2 Experiment-2 Oscilloscope Examination of Variable Load Wind Turbine Charge Control System

Modules required for the experiment;

- Wind Turbine Module
- Monophase Switching Module,
- Energy Distribution Module,
- PC Interface Module, (Optional)
- Wind Simulator Module (WS),
- AC/DC Measurement Module (MM),
- Electronic Potentiometer Module (EP),
- Isolated Measurement Module,
- Wind Turbine Charge Control Module,

Experiment Connection;

1. First, connect the energy input to the Energy Distribution Module using a Banana Jack cables for safety reasons.
2. Then, connect the Energy Distribution Module using Banana Jack cables.
3. Next, connect the power input for the Wind Simulator Module and the Banana Jack cables of the Wind Turbine to the Wind Simulator Module.
4. Connect the three-phase output of the wind turbine to the inputs of the Wind Turbine Charge Control Module.
5. Connect the outputs of the Wind Turbine Charge Control Module to the Electronic Potentiometer Module via the ammeter of the AC/DC Measurement Module.
6. Connect the voltmeter section of the AC/DC Measurement Module to the Electronic Potentiometer Module.
7. To complete the setup, connect the inputs of the Isolated Measurement Module between the two windings of the Wind Turbine.
8. Then, connect the Isolated Measurement Module to an oscilloscope.

- If you would like to view the measured data and control your wind speed via computer, make the power connection of the PC Interface Module and connect the AC/DC Measurement Module and Wind Simulator Module to the PC Interface Module with CAT6 cable.

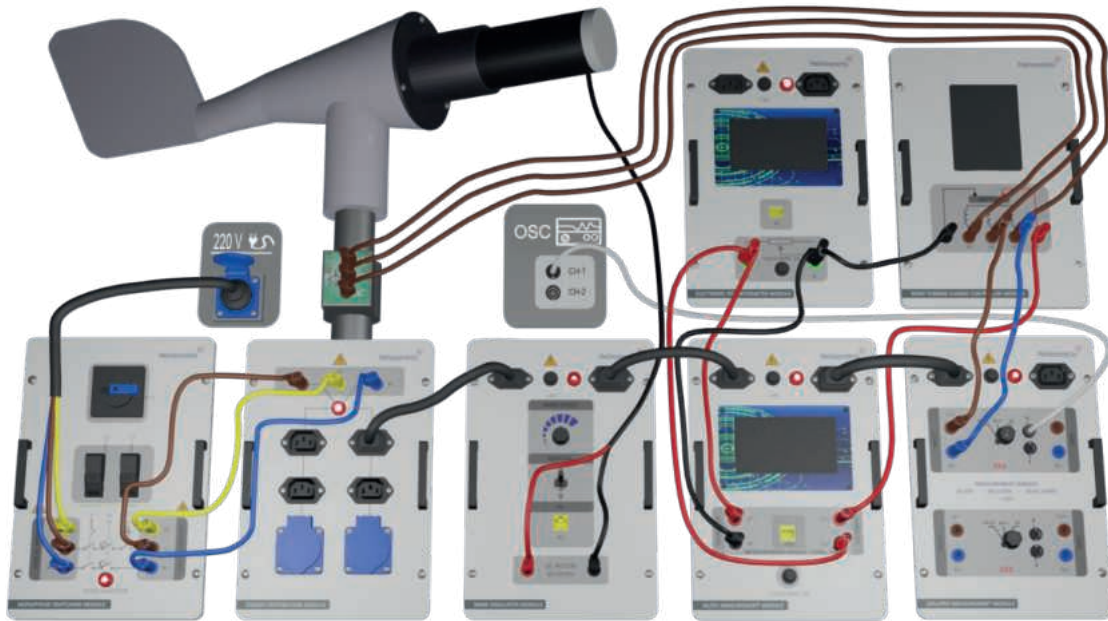

Figure-75 Installation Image of Examination of Variable Load Wind Turbine Charge Control System

Stages of the Experiment;

- Make the connection as illustrated in Figure-75. Ensure that the caster of the wind turbine is locked to prevent movement.
- Set the Wind Simulator Module switch to MANUAL mode. Adjust the SPEED potentiometer to its minimum position.
- Record the readings from both the voltmeter and ammeter in Table-57.
- Gradually increase the wind speed by adjusting the SPEED potentiometer, setting it to level 1. Use the following equation to calculate the wind speed:

$$n = \frac{60 \cdot f}{2P}$$

f = Frequency (Hz)

2P = Number of Poles

Record the calculated wind speed in Table-57 under "1. SPEED".

- Set the wind speed to the maximum. Proceed to take the desired measurements using the Electronic Potentiometer, and record these values in Table-57.

RL (Ohm/)	Voltage (v)	Current (I)	(Frequency) Hz	Period (Rpm)
1000	27,72	0,029	104	1040
100	24,75	0,259	97	970
50	23,24	0,727	93	930
30	21,53	0,727	87	870
25	20,89	0,833	86	860
20	19,84	0,988	85	850
15	18,93	1,21	80	800
10	16,20	1,58	74	740
5	11,8	2,25	63	630
3	8,92	2,73	54	540
1	4,42	3,42	41	410

Table-57

6. Using the data recorded in the provided table, draw three separate graphs: Load-Current Graph, Load-Voltage Graph, and Load-Power Graph. Each graph will visually represent the relationship between the respective variables.

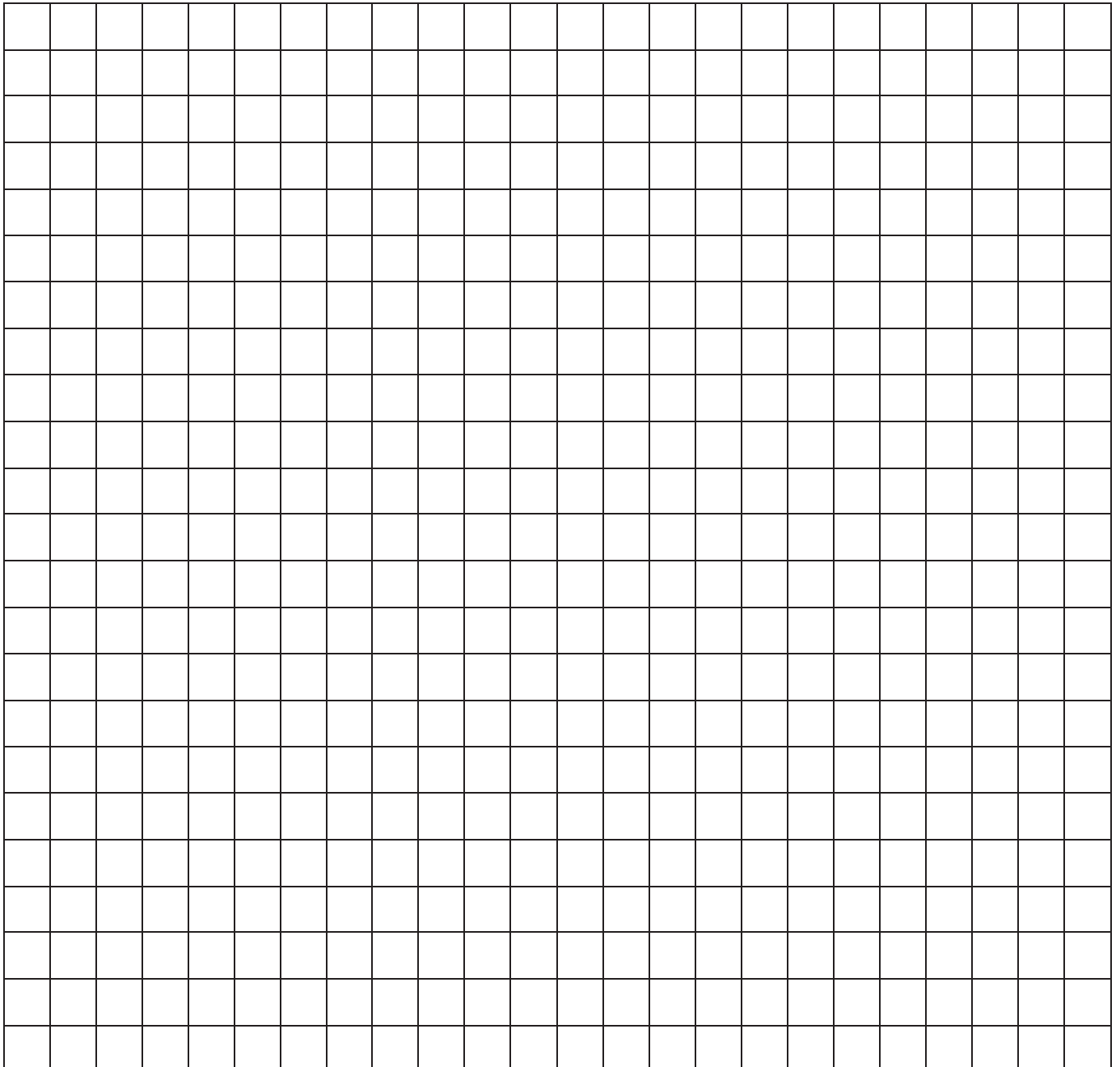

Graph-1

7. Compare the graphs you have drawn with the reference graphs provided. Analyze any similarities or differences in the patterns, trends, and key points between your graphs and the provided ones. This comparison will help in understanding the accuracy and consistency of your experimental results.
8. Compare the output voltages during loaded (when the turbine is connected to a load) and unloaded (without any load connected) operations. This comparison is crucial to understand how the presence of a load affects the wind turbine's output voltage. Record and analyze the differences in output voltage under these two conditions.
9. Finally, incrementally increase the wind speed by adjusting the SPEED potentiometer towards its maximum position. Closely observe the charging voltage and current when there is no load connected. Be aware that if the output voltage exceeds 15 volts, the system will engage its braking mechanism. To observe this braking process, first disconnect the battery from the charge controller. Then, switch the system to no-load operation and carefully turn the SPEED potentiometer towards its maximum position. Once the braking mechanism activates, deactivate the braking by lowering the SPEED potentiometer back down. This step is important to understand the safety features of the system and how it responds to over-voltage conditions.

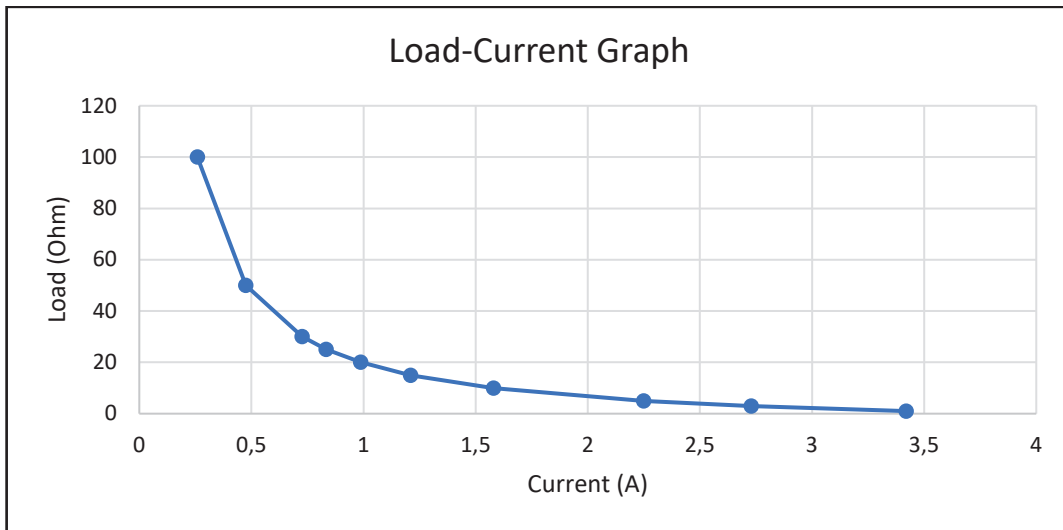

Graph XI

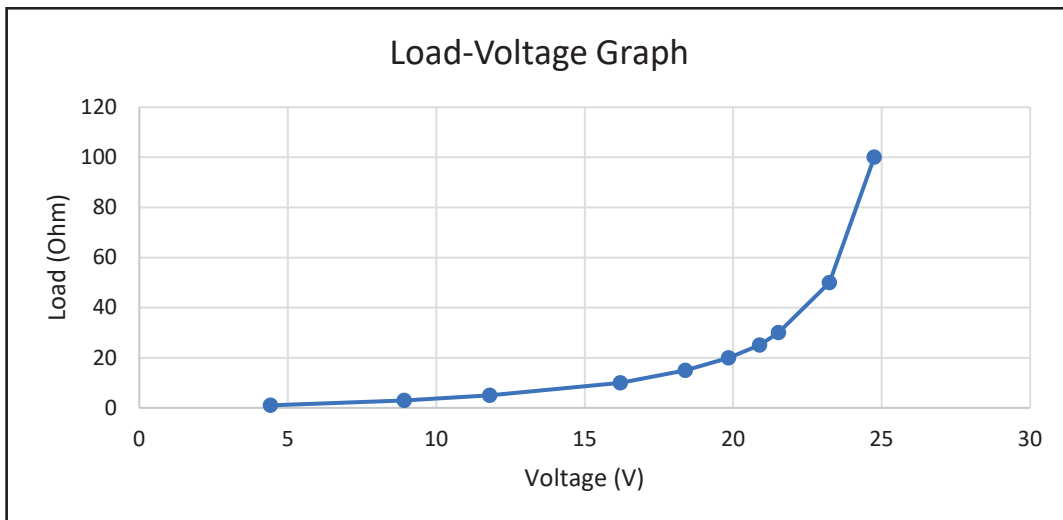

Graph XII

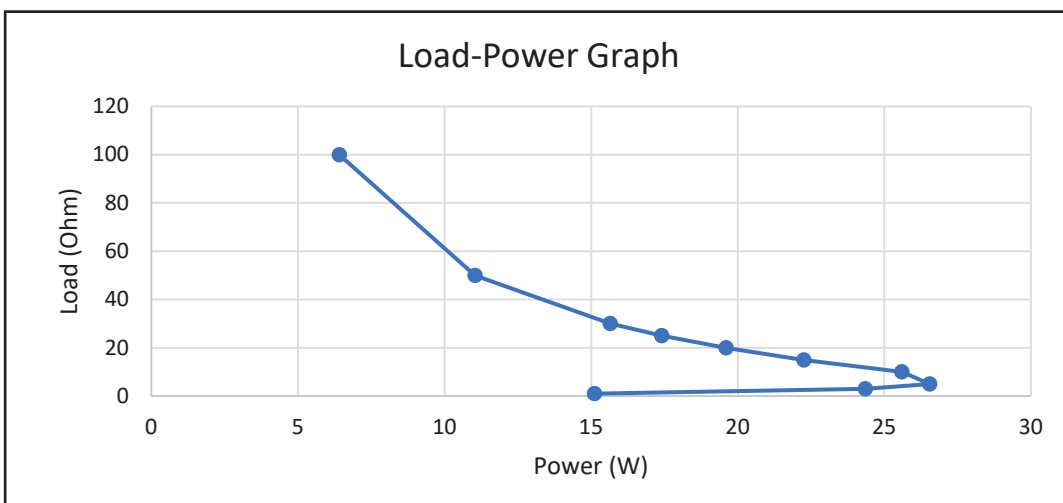

Graph XIII

6.3 Experiment-3 Examination of Variable Load Wind Turbine Charge Control System with Battery

Modules required for the experiment;

- Wind Turbine Module
- Monophase Switching Module,
- Energy Distribution Module,
- PC Interface Module, (Optional)
- Wind Simulator Module (WS),
- AC/DC Measurement Module (MM),
- Electronic Potentiometer Module (EP),
- Isolated Measurement Module,
- Wind Turbine Charge Control Module,
- Accumulator Module,

Experiment Connection;

1. First, connect the energy input to the Energy Distribution Module using a Banana Jack cables for safety reasons.
2. Then, connect the Energy Distribution Module using Banana Jack cables.
3. Connect the power input for the Wind Simulator Module and the Banana Jack cables of the Wind Turbine to the Wind Simulator Module.
4. Connect the three-phase output of the wind turbine to the inputs of the Wind Turbine Charge Control Module.
5. Connect the outputs of the Wind Turbine Charge Control Module to the Accumulator Module via the ammeter of the AC/DC Measurement Module.
6. Series connect the Electronic Potentiometer Module to the Accumulator Module.
7. Connect the voltmeter section of the AC/DC Measurement Module to the Electronic Potentiometer Module.

8. To complete the setup, connect the inputs of the Isolated Measurement Module between the two windings of the Wind Turbine.
9. Then, connect the Isolated Measurement Module to an oscilloscope.
10. If you would like to view the measured data and control your wind speed via computer, make the power connection of the PC Interface Module and connect the AC/DC Measurement Module and Wind Simulator Module to the PC Interface Module with CAT6 cable.

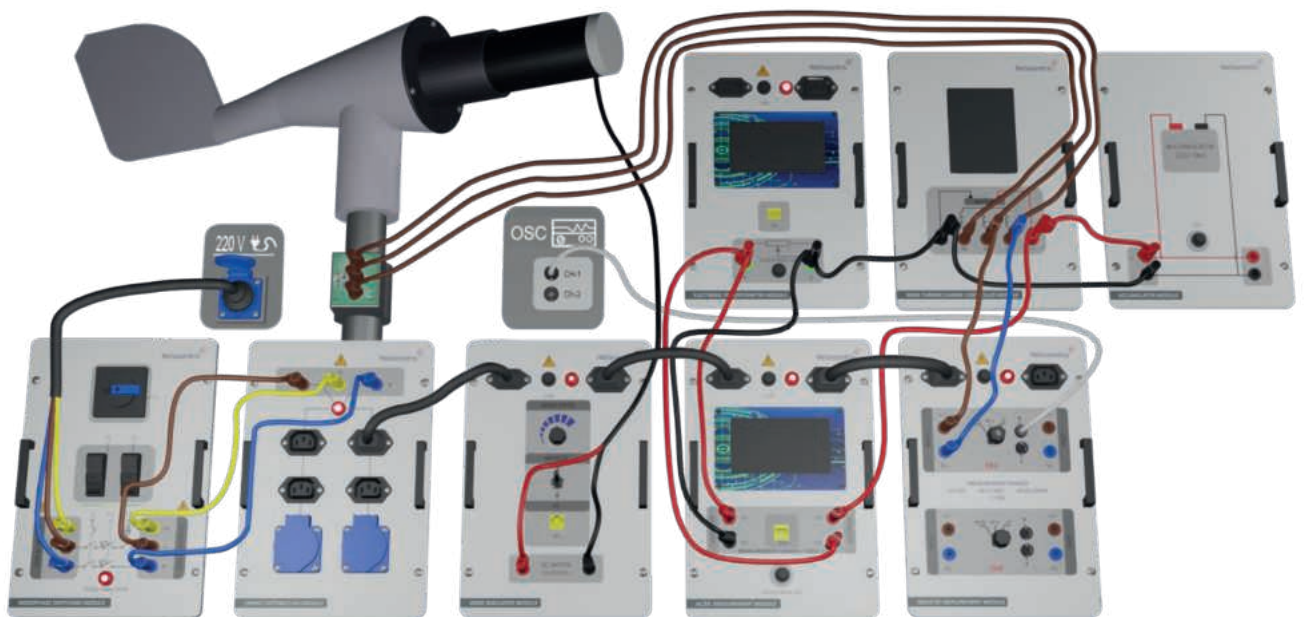

Figure-76. Installation Image of Examination of Variable Load Wind Turbine Charge Control System with Battery

Stages of the Experiment;

1. Make the connection as shown in Figure-76. Ensure that the caster of the wind turbine is locked to prevent movement.
2. Set the Wind Simulator Module switch to MANUAL mode. Adjust the SPEED potentiometer to its minimum position.
3. Record the readings from both the voltmeter and ammeter in Table-58.
4. Gradually increase the wind speed by adjusting the SPEED potentiometer to level 1. Use the following equation to calculate the wind speed:

$$n = \frac{60 \cdot f}{2P}$$

f = Frequency (Hz)

2P = Number of Poles

Record the calculated wind speed in Table-58 under "1. SPEED".

- Set the wind speed to its maximum setting. Proceed to make the desired measurements by adjusting the electronic potentiometer, and record these values in Table-58.

RL (Ohm/	Voltage (v)	Current (I)	(Frequency) Hz	Period (Rpm)
1000	12,38	0,013	64	640
100	12,28	0,12	64	640
50	12,25	0,251	64	640
30	12,22	0,414	64	640
25	12,2	0,507	64	640
20	12,17	0,606	64	640
15	12,12	0,797	63,29	632,9
10	12,04	1,17	63,29	632,9
5	11,76	2,25	63,29	632,9
3	11,56	3,51	62,5	625
1	10	7,86	61,75	617,5

Table-58

- Draw the Load-Current Graph, Load-Voltage Graph, and Load-Power Graph using the data recorded in the table.

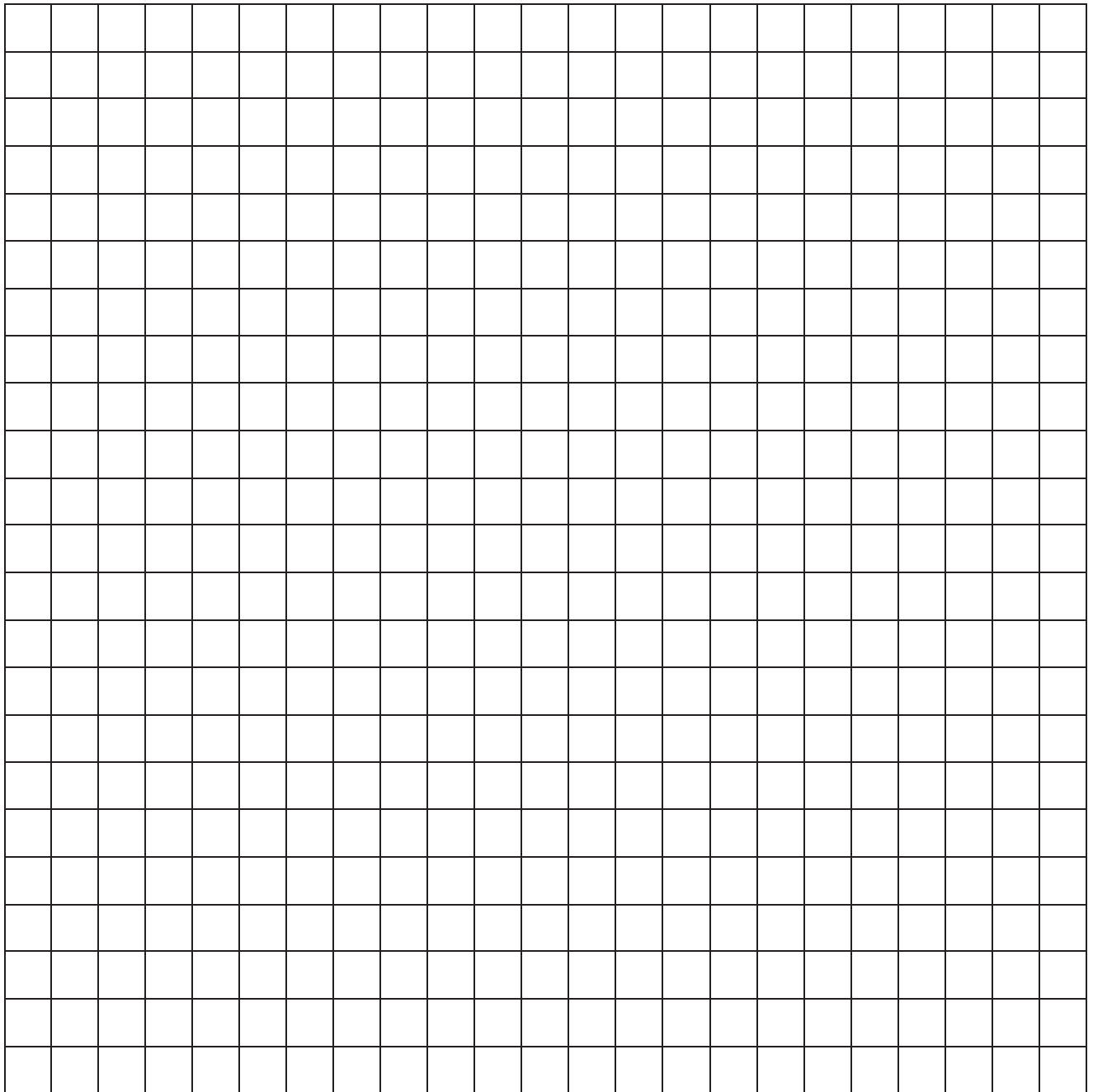

Graph-1

7. Compare the output parameters you have recorded with the provided graphs. Analyze any similarities or differences to understand how the experimental results align with the expected outcomes.

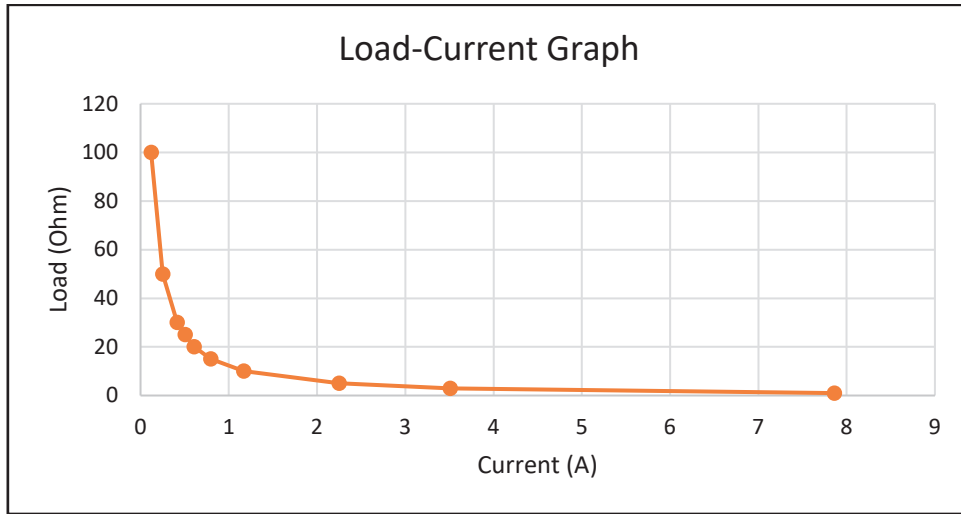

Graph XIV

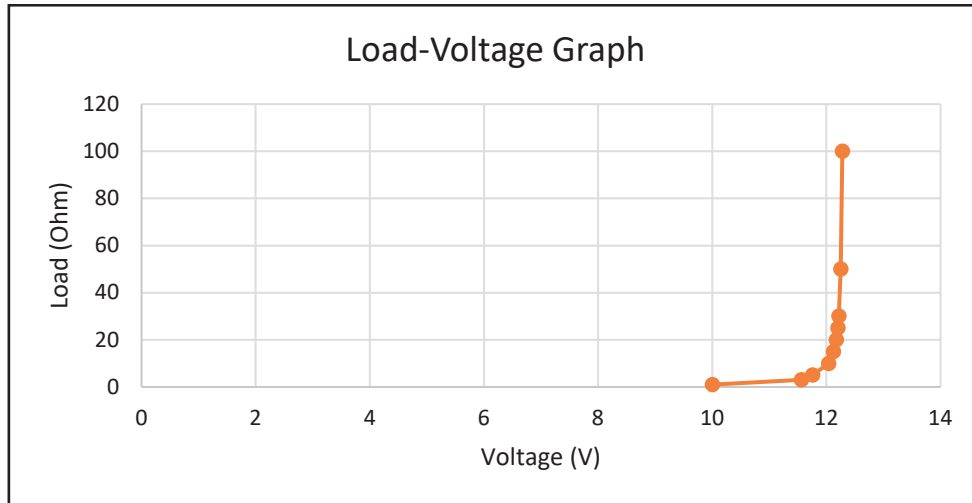

Graph XV

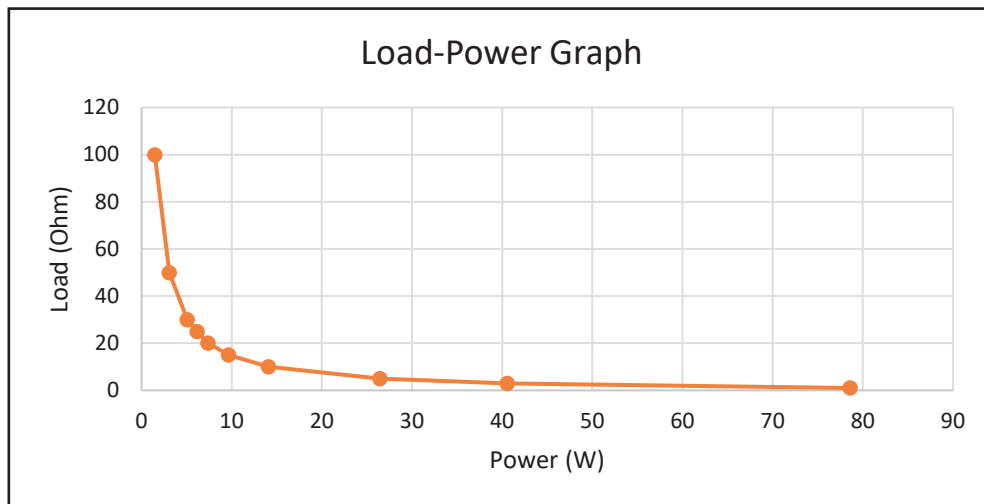

Graph XVI

6.4 Experiment-4 Examination of Wind Turbine Output Voltage with DAQ Module

Modules required for the experiment;

- Wind Turbine Module
- Monophase Switching Module,
- Energy Distribution Module,
- PC Interface Module, (Optional)
- Wind Simulator Module (WS),
- AC/DC Measurement Module (MM),
- Isolated Measurement Module,
- Wind Turbine Charge Control Module,
- Data Acquisition Module,

Experiment Connection;

1. First, connect the energy input to the Energy Distribution Module using a Banana Jack cables for safety reasons.
2. Subsequently, connect the Energy Distribution Module using Banana Jack cables.
3. Connect the power input for the Wind Simulator Module and the Banana Jack cables of the Wind Turbine to the Wind Simulator Module.
4. Connect the three-phase output of the wind turbine to the inputs of the Wind Turbine Charge Control Module.
5. Connect two of the three-phase winding terminals of the wind turbine to the inputs of the Isolated Measurement Module.
6. Connect the analog input of the Data Acquisition Module to the BNC terminal of the Isolated Measurement Module using a BNC to Banana Jack cable.
7. If you would like to view the measured data and control your wind speed via computer, make the power connection of the PC Interface Module and connect the AC/DC Measurement Module and Wind Simulator Module to the PC Interface Module with CAT6 cable.

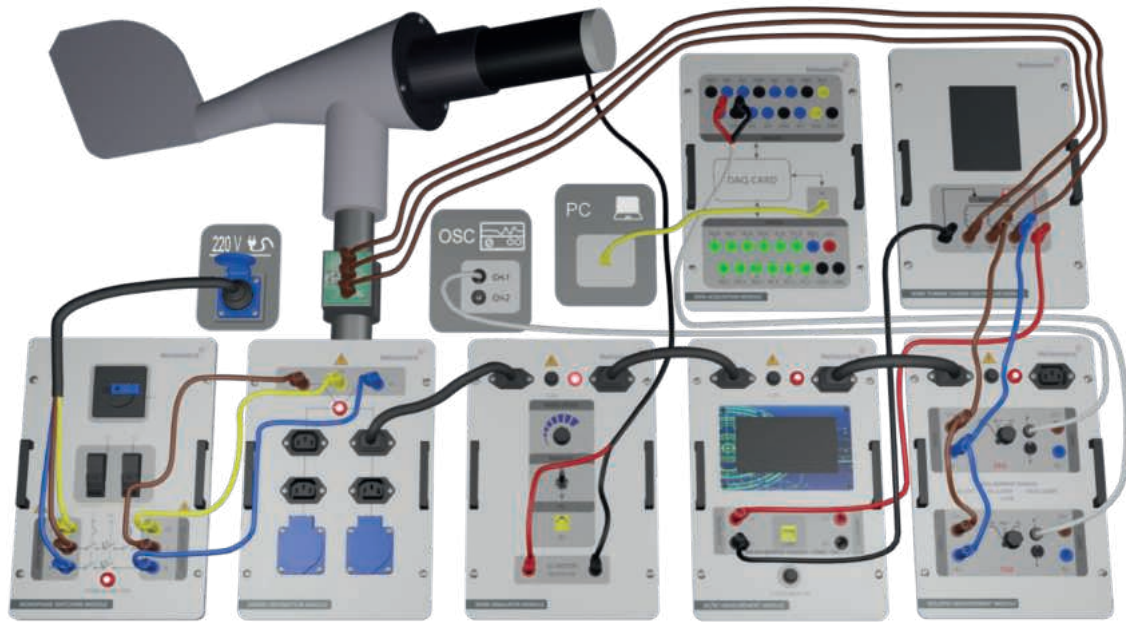
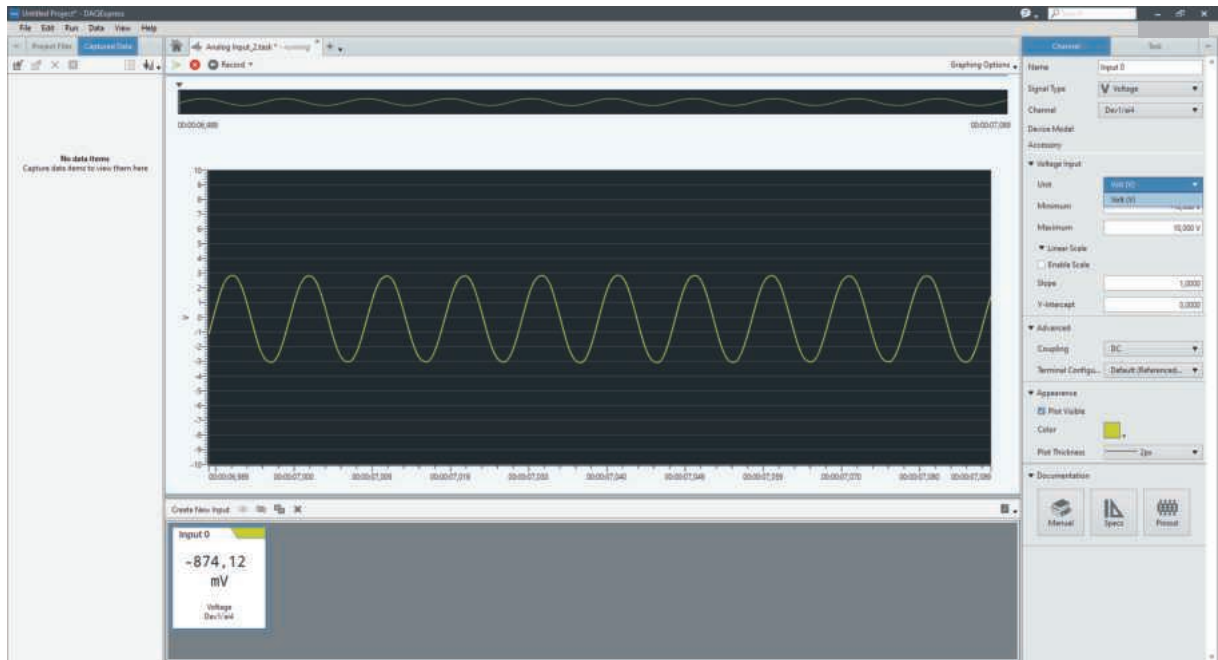

Figure-77. Installation Image of Examination of Wind Turbine Output Voltage with DAQ Module

Stages of the Experiment;

1. Make the connection as illustrated in Figure-77. Ensure that the caster of the wind turbine is locked to prevent any movement.
2. Set the Wind Simulator Module switch to MANUAL mode and adjust the SPEED potentiometer to its minimum position.
3. Set the commutator of the channel on the Isolated Measurement Module to the X0.1 position.
4. Establish the USB connection between the Data Acquisition Module and the computer.
5. Open the DAQ Express application on the PC.
6. Adjust the settings in DAQ Express to analyze the signal.
7. Gradually increase the wind speed by adjusting the SPEED potentiometer. Observe the changes in the shape of the output signal as the speed increases.
8. Set the SPEED potentiometer to the maximum speed position. Observe the signal and draw the signal shape as displayed on the computer in Graph-1.



Picture-2

9. Click the 'Save' button in DAQ Express to save the signal for detailed analysis.

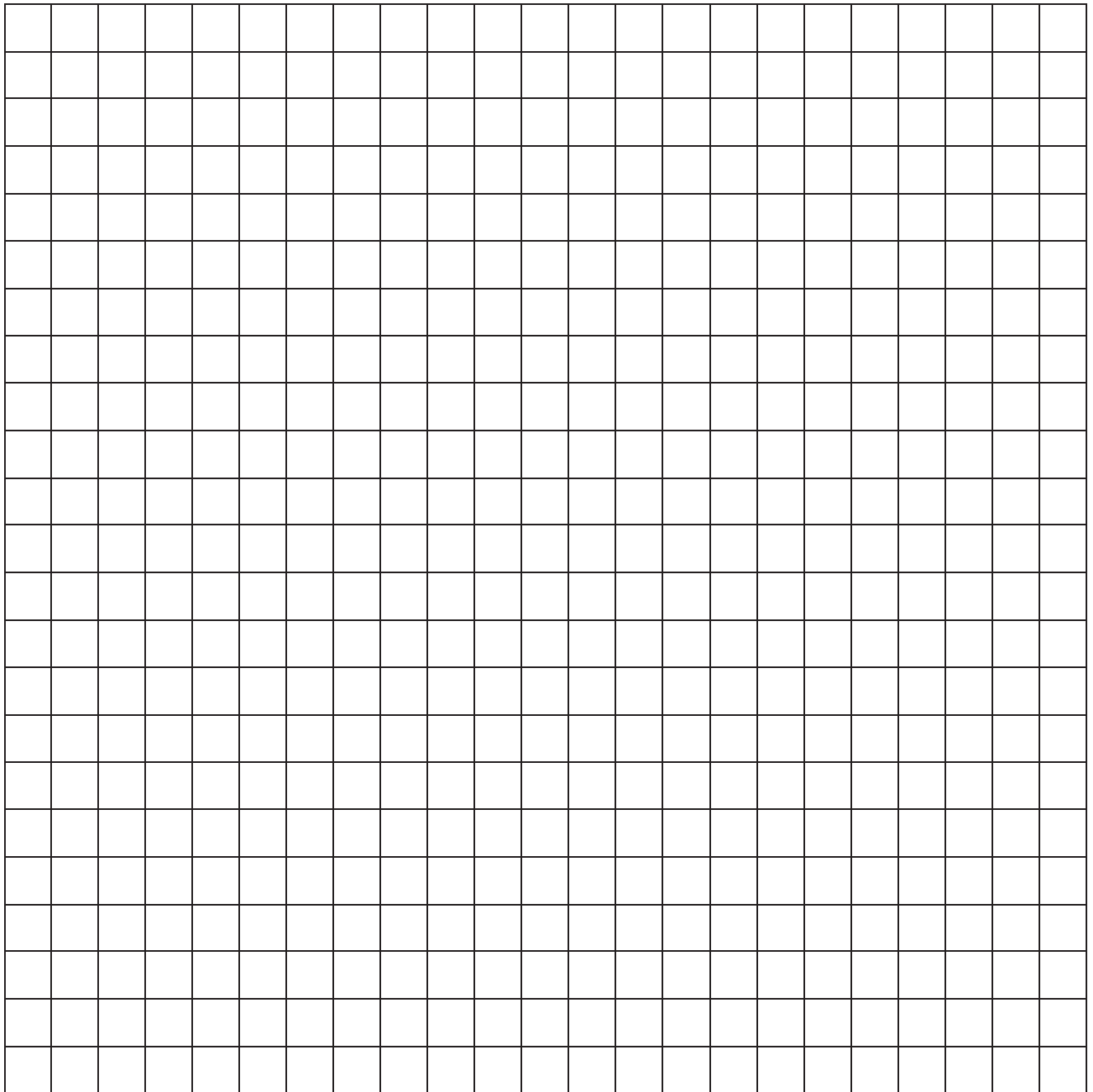

Graph-1

7. Hydrogen Energy Systems

Hydrogen is abundant in most stars and planets, but it is relatively scarce in Earth's atmosphere, present at a rate of about 7 parts per ten thousand. Consequently, hydrogen must be produced from other sources. Local sources of hydrogen include fossil fuels (C_xH_y) and water (H_2O). Currently, the primary production method of hydrogen is from fossil fuels such as natural gas, oil, and coal. Despite its potential, hydrogen has not been widely used as a fuel or energy carrier outside of space programs, although it has seen various applications in the chemical, metallurgical, and refining industries. As an energy carrier, hydrogen production will need to significantly increase in the coming years.

Hydrogen production often involves the use of an electrolysis device, which is powered by electricity generated from renewable sources like wind or solar energy. This device splits water into its constituent hydrogen and oxygen components. The produced H_2 and O_2 gases are then stored and can be used in various systems, such as fuel cells.

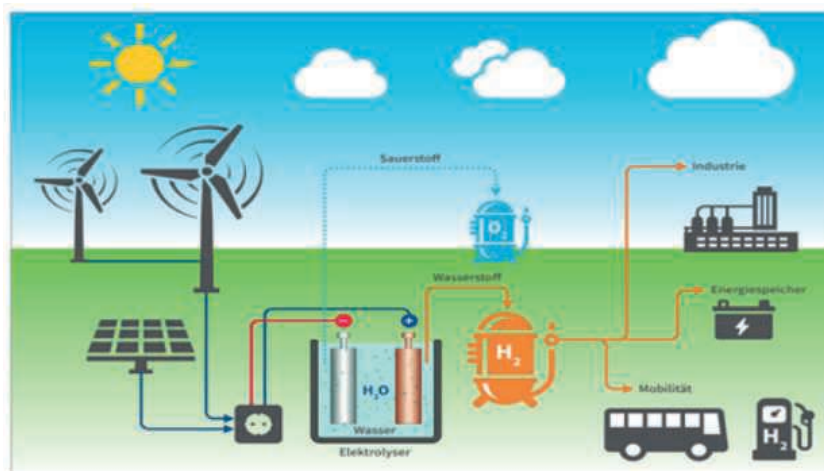

Figure-78. Hydrogen Conversion and Distribution

Electrolysis is a process of separating water into hydrogen and oxygen using direct current and is considered the simplest method for hydrogen production. An electrolysis cell typically consists of two electrodes, usually made of flat metal or carbon plates, immersed in a conductive liquid known as an electrolyte. When a direct current source is connected to these electrodes, current flows through the conductive liquid from the positive electrode (anode) to the negative electrode (cathode). This process results in the decomposition of water, producing hydrogen at the cathode and oxygen at the anode. To enhance conductivity, an electrolyte such as potassium hydroxide is commonly added to the water.



Figure-79. Hydrofill Pro Electrolysis Device and Hyrostick Hydrogen Battery

The fuel cell directly converts fuel into electrical energy through an electrochemical reaction. It generates electricity by externally supplying a fuel (at the anode side) and an oxidizer (at the cathode side) to an electrolyte/electrode unit. Typically, the reactants enter the cell, and the reaction products leave the cell. Fuel cells can operate continuously as long as there is a sustained flow of fuel and oxidizer.

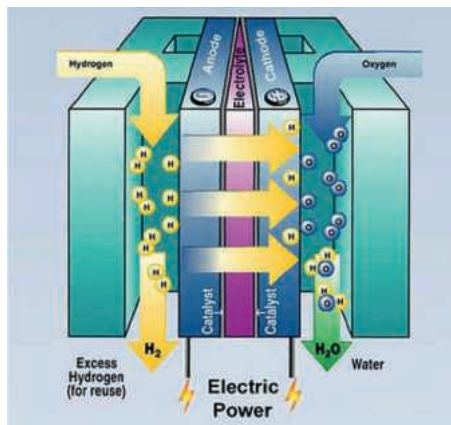

Figure-80. Internal Structure of a Fuel Cell

Hydrogen fuel technology is increasingly being utilized in various sectors, including in fuel cell-powered vehicles and electric power generation plants. This technology is key in the move towards cleaner energy solutions and has a wide range of applications due to its efficiency and environmental benefits.

8. Applications of Hydrogen Energy Training Kit

!!! **NOTE:** In experiments where a controller is not present, it's necessary to remove the valve tube to prevent any damage to the Fuel Cell.

8.1 Experiment-1 Examination of Hydrogen Fuel Cell Output Voltage with Oscilloscope

Modules required for the experiment;

- Fuel Cell Module,
- Monophase Switching Module,
- Energy Distribution Module,
- PC Interface Module, (Optional)
- AC/DC Measurement Module (MM),
- Isolated Measurement Module,

Experiment Connection;

1. First, connect the energy input to the Energy Distribution Module using a Banana Jack cables for safety reasons.
2. Then, connect the Energy Distribution Module using Banana Jack cables.
3. Connect the hydrogen battery to the fuel cell inlet. Once connected, the fuel cell's LED lights will illuminate, indicating that the module is operational.
4. Connect the AC/DC Measurement Module's voltmeter to the fuel cell's output.
5. Connect the outputs to the input of the Isolated Measurement Module and then connect the oscilloscope to this module.
6. If you would like to view the measured data via computer, make the power connection of the PC Interface Module and connect the AC/DC Measurement Module to the PC Interface Module with CAT6 cable.

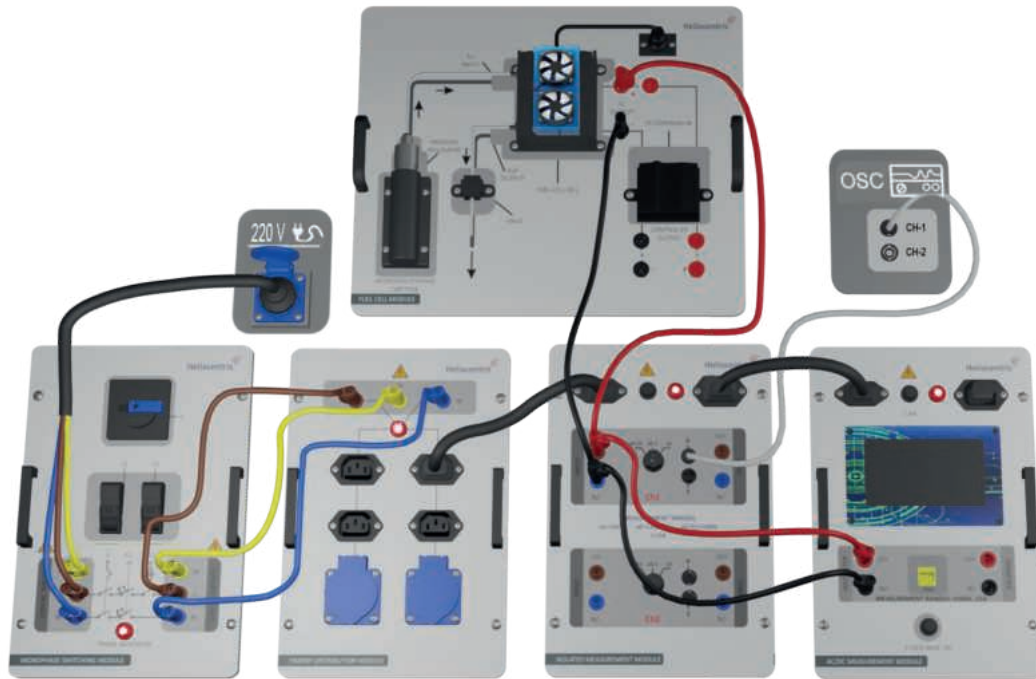
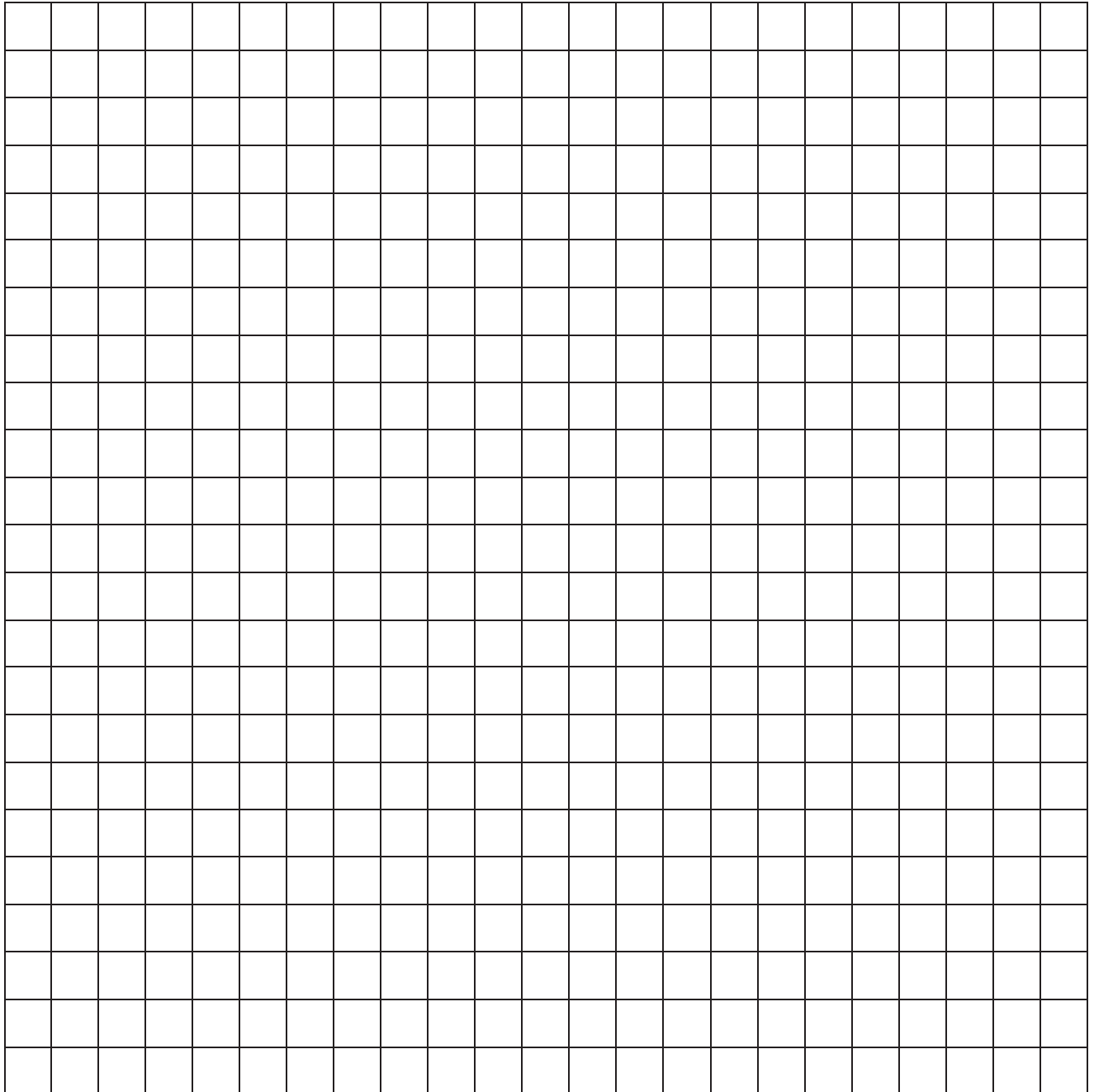

Figure-81. Installation Image of Examination of Hydrogen Fuel Cell Output Voltage with Oscilloscope

Stages of the Experiment;

1. Connect the setup as illustrated in Figure-81. Ensure that the hydrogen battery is fully charged before use to prevent obtaining inaccurate results.
2. Set the commutator for channel CH1 on the Isolated Measurement Module to X0.1.
3. Ensure the Hydrostick is properly connected, as this is crucial for safety.
4. In experiments where a controller is not present, it is necessary to remove the valve tube to prevent any damage to the Fuel Cell.
5. Adjust the oscilloscope settings as necessary and measure the shape of the output signal. Plot the signal shape in the designated area on Graph-1. Ensure that the signal is attenuated at a ratio of 1:10 during both measurement and drawing.
6. Record the voltmeter reading (V_O) in the MM module. Document the value as:

$$V_O = \dots \dots V$$
7. Explain the working principle of a hydrogen fuel cell, focusing on how it converts hydrogen into electrical energy through an electrochemical reaction.



Graph-1

8.2 Experiment-2 Examination of Hydrogen Fuel Cell Output Voltage Under Load with Oscilloscope

Modules required for the experiment;

- Fuel Cell Module,
- Monophase Switching Module,
- Energy Distribution Module,
- PC Interface Module, (Optional)
- AC/DC Measurement Module (MM),
- Electronic Potentiometer Module (EP)
- Isolated Measurement Module,

Experiment Connection;

1. First, connect the energy input to the Energy Distribution Module using a Banana Jack cables for safety reasons.
2. Subsequently, connect the Energy Distribution Module using Banana Jack cables.
3. Connect the hydrogen battery to the fuel cell inlet. Once connected, the fuel cell's LED lights will illuminate, indicating that the module is operational.
4. Connect the output of the fuel cell to the potentiometer via the ammeter on the AC/DC Measurement Module.
5. Then, connect the voltmeter of the AC/DC Measurement Module to the Electronic Potentiometer.
6. Connect the outputs to the input of the Isolated Measurement Module and then connect the oscilloscope to this module.
7. If you would like to view the measured data via computer, make the power connection of the PC Interface Module and connect the AC/DC Measurement Module to the PC Interface Module with CAT6 cable.



Figure-82. Installation Image of Examination of Hydrogen Fuel Cell Output Voltage Under Load with Oscilloscope

Stages of the Experiment;

1. Connect the setup as illustrated in Figure-82. Make sure that the hydrogen battery is fully charged before use to avoid obtaining inaccurate results.
2. Set the commutator for channel CH1 on the Isolated Measurement Module to X0.1.
3. Ensure the Hydrostick is properly connected, as this is crucial for maintaining safety.
4. In experiments where a controller is not present, it is necessary to remove the valve tube to prevent any damage to the Fuel Cell.
5. Start with a resistance of 1000Ω on the potentiometer. Gradually decrease the resistance according to the data specified in Table-59. As you adjust the potentiometer, record the voltage and current values on the AC/DC Measurement Module (MM).

Load	Fuel Cell Output	
	Voltage(V)	Current(mA)
R_L		
1000	10,65	11,00
900	10,64	13,00
800	10,61	14,00
700	10,59	16,00
600	10,57	19,00
500	10,55	22,00
400	10,52	27,00
300	10,47	37,00
200	10,48	54,00
100	10,16	105,00
90	10,12	117,00
80	10,06	131,00
70	10,00	148,00
60	9,92	171,00
50	9,81	202,00
40	9,65	246,00
30	9,42	320,00
20	9,05	452,00
10	8,21	804,00
9	8,12	888,00
8	7,99	979,00
7	7,80	1.090,00
6	7,58	1.230,00
5	7,30	1.400,00
4	6,92	1.640,00
3	6,41	1.980,00
2	5,61	2.520,00

Table-59

- Using the data you've recorded, draw the current-voltage (I-V) graph in the specified area. This graph will visually represent the relationship between the current and voltage for the different resistance settings you have tested.

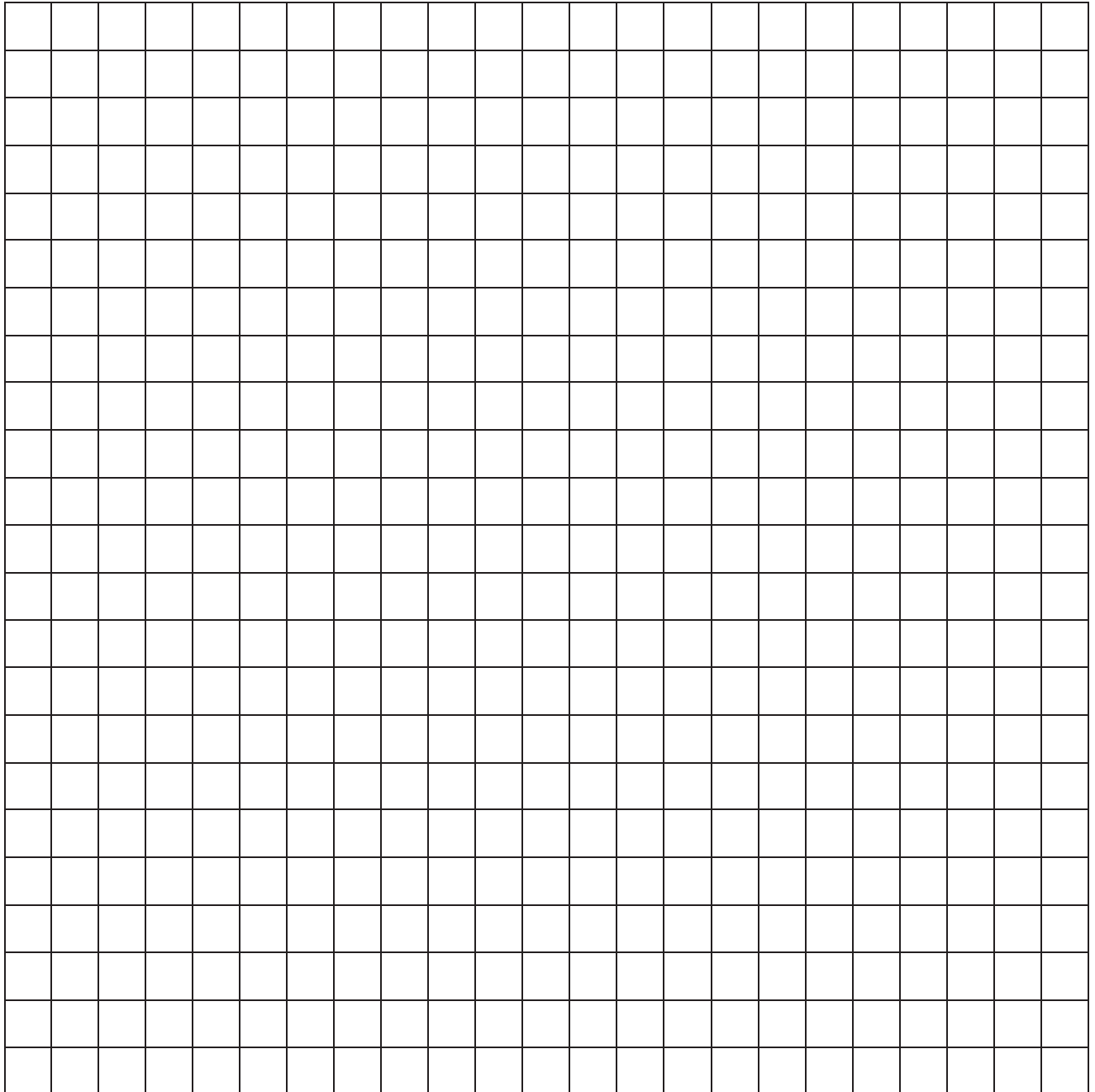

Graph-1

7. Compare the graph you have drawn with the reference graph provided. Analyze any similarities or differences in the patterns, slopes, and key points between your graph and the provided one. This comparison will help you understand the accuracy of your experimental results and any deviations from the expected behaviour.

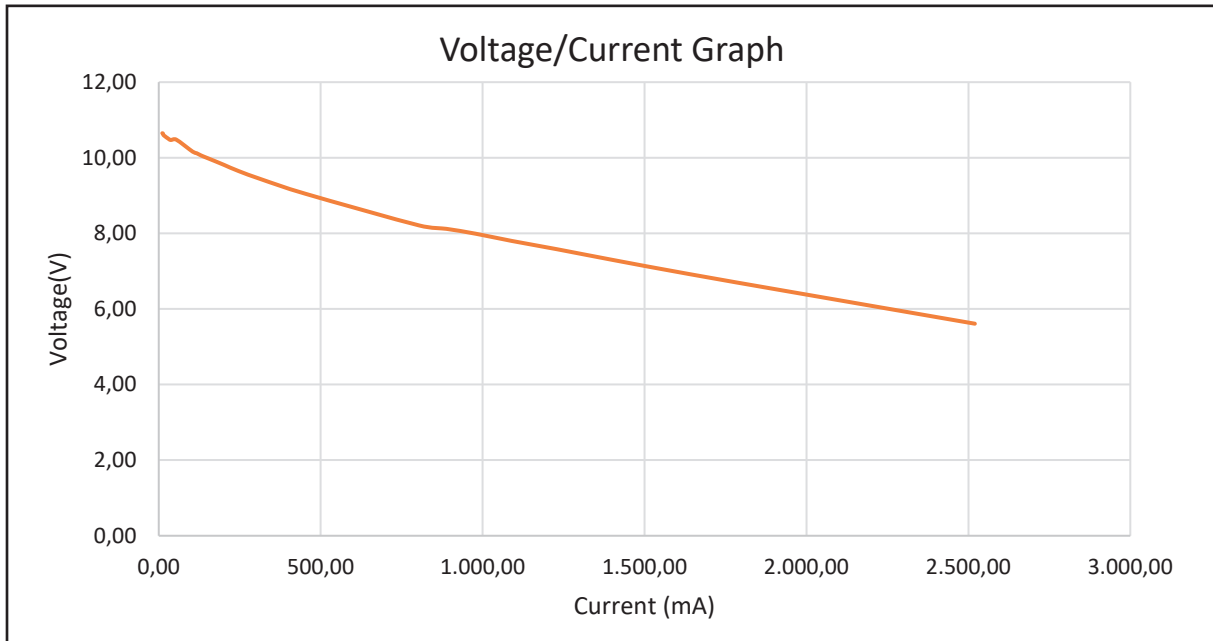

Graph XVII

8.3 Experiment-3 Examination of Output Voltage from Hydrogen Fuel Cell DC/DC Converter using an Oscilloscope

Modules required for the experiment;

- Fuel Cell Module,
- Monophase Switching Module,
- Energy Distribution Module,
- PC Interface Module, (Optional)
- AC/DC Measurement Module (MM),
- Isolated Measurement Module,

Experiment Connection;

1. First, connect the energy input to the Energy Distribution Module using a Banana Jack cables for safety reasons.
2. Then, connect the Energy Distribution Module using Banana Jack cables.
3. Short-circuit the two red binding posts located next to each other at the outlet of the fuel cell.
4. Connect the hydrogen battery to the fuel cell inlet. Once connected, the fuel cell's LED lights will illuminate, indicating that the module is operational.
5. Connect the AC/DC Measurement Module's voltmeter to the controller outputs.
6. Connect the outputs to the input of the Isolated Measurement Module and then connect the oscilloscope to this module.
7. If you would like to view the measured data via computer, make the power connection of the PC Interface Module and connect the AC/DC Measurement Module to the PC Interface Module with CAT6 cable.

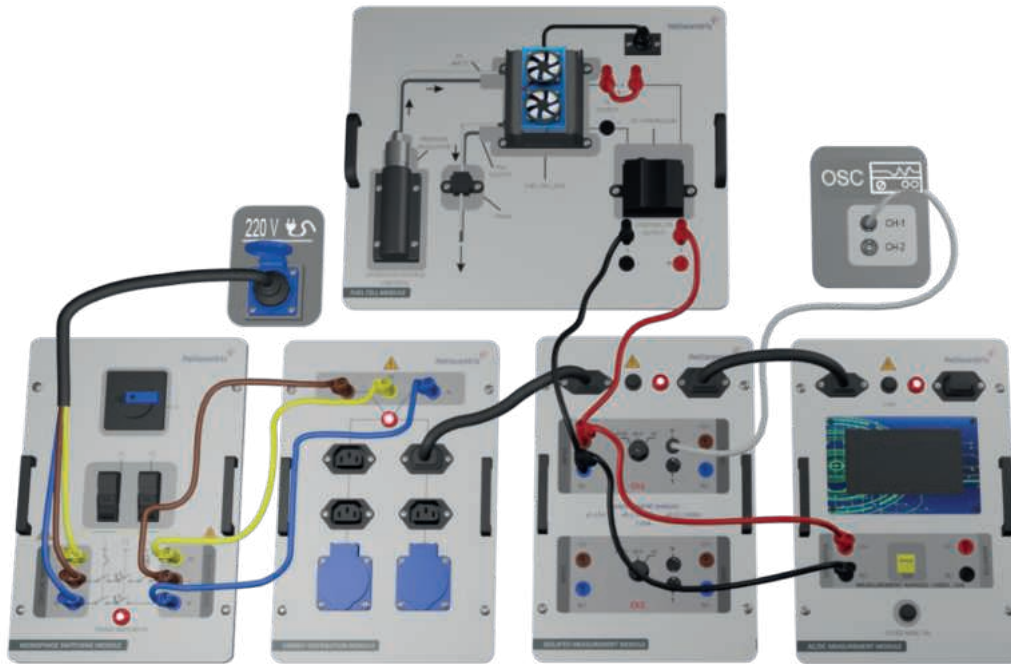

Figure-83. Installation Image of Examination of Output Voltage from Hydrogen Fuel Cell DC/DC Converter using an Oscilloscope

Stages of the Experiment;

1. Connect the setup as illustrated in Figure-83. Ensure that the hydrogen battery is fully charged before use to avoid obtaining inaccurate results.
2. Set the commutator for channel CH1 on the Isolated Measurement Module to the X0.1 position.
3. Make sure the Hydrostick is properly connected, as this is crucial for safety.
4. Adjust the oscilloscope settings as necessary and measure the shape of the output signal. Plot the signal shape in the designated area on Graph-1. Ensure that the signal is attenuated at a ratio of 1:10 during both measurement and drawing.
5. Record the voltmeter reading (VO) in the MM module. Document the value as:

$$V_O = \dots \dots V$$

6. Analyze and explain the cause of the periodic drop in the signal shape. This involves understanding the underlying electrochemical processes in the fuel cell and how they may lead to fluctuations or variations in the output signal.

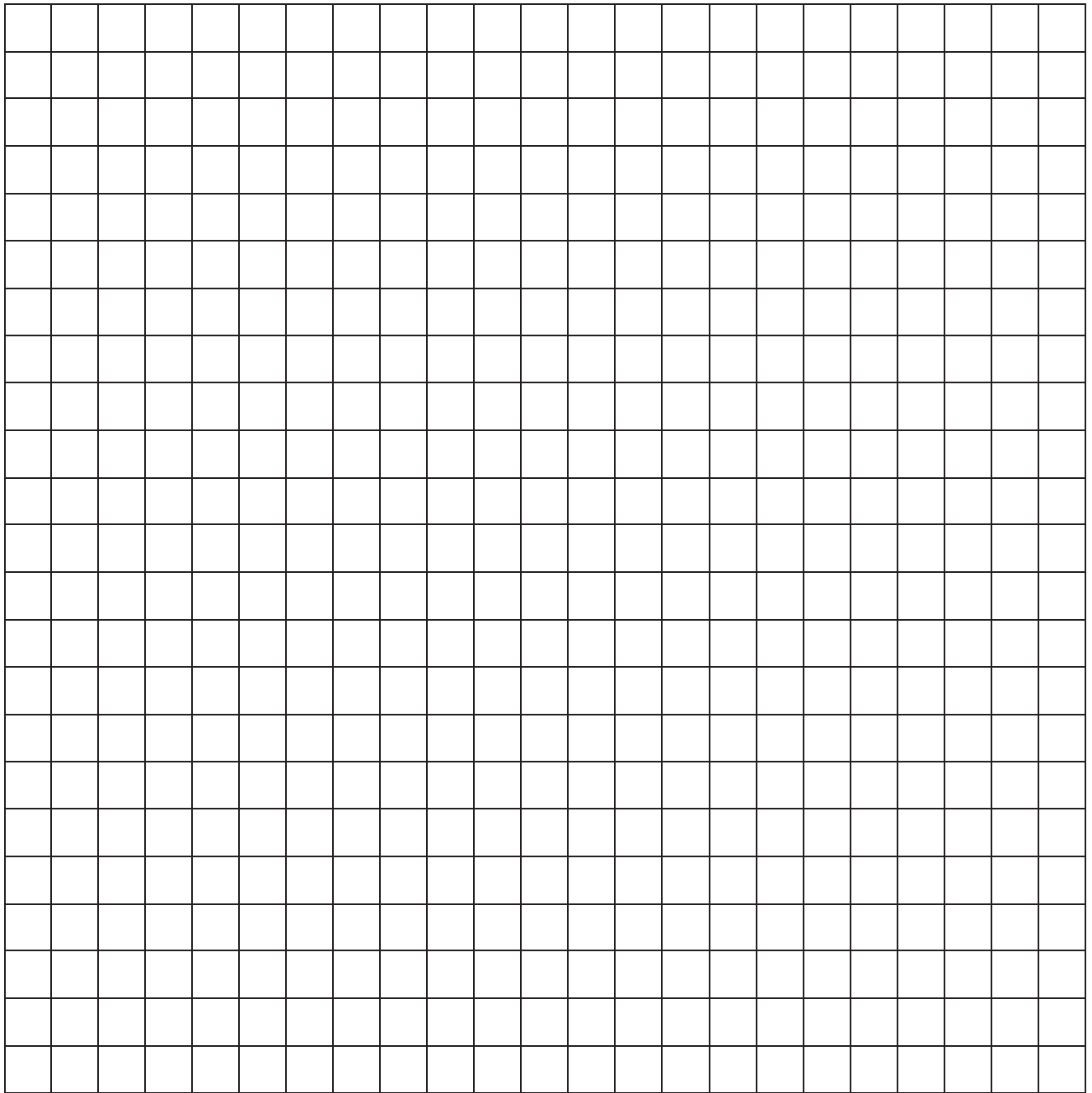

Graph-1

8.4 Experiment-4 Examination of Hydrogen Fuel Cell DC/DC Converter Output Voltage Under Load with Oscilloscope

Modules required for the experiment;

- Fuel Cell Module,
- Monophase Switching Module,
- Energy Distribution Module,
- PC Interface Module, (Optional)
- AC/DC Measurement Module (MM),
- Isolated Measurement Module,

Experiment Connection;

1. First, connect the energy input to the Energy Distribution Module using a Banana Jack cables for safety reasons.
2. Then, connect the Energy Distribution Module using Banana Jack cables.
3. Short-circuit the two red binding posts located next to each other at the outlet of the fuel cell.
4. Connect the hydrogen battery to the fuel cell inlet. Once connected, the fuel cell's LED lights will illuminate, indicating that the module is operational.
5. Connect the output of the controller to the potentiometer via the ammeter on the AC/DC Measurement Module.
6. Then, connect the voltmeter of the AC/DC Measurement Module to the Electronic Potentiometer.
7. Connect the outputs to the input of the Isolated Measurement Module and then connect the oscilloscope to this module.
8. If you would like to view the measured data via computer, make the power connection of the PC Interface Module and connect the AC/DC Measurement Module to the PC Interface Module with CAT6 cable.

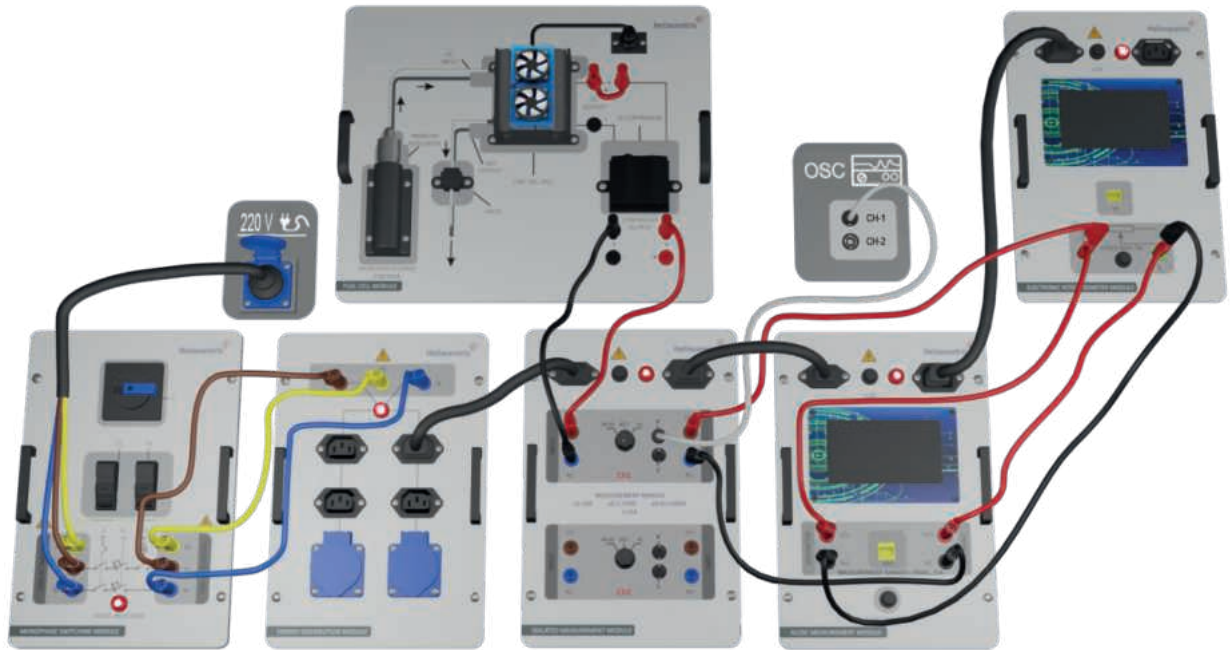

Figure-84. Installation Image of Examination of Hydrogen Fuel Cell DC/DC Converter Output Voltage Under Load with Oscilloscope

Stages of the Experiment;

1. Connect the setup as illustrated in Figure-84. Make sure that the hydrogen battery is fully charged before use to avoid obtaining inaccurate results.
2. Set the commutator for channel CH1 on the Isolated Measurement Module to the X0.1 position.
3. Ensure that the Hydrostick is properly connected, as this is crucial for safety.
4. Start with a resistance setting of 1000Ω on the potentiometer. Gradually decrease the resistance according to the data specified in Table-60. As you adjust the potentiometer, record the voltage and current values on the AC/DC Measurement Module (MM).

Load	Controller Output	
	Voltage(V)	Current(mA)
R_L		
1000	10,51	11,00
900	10,50	12,00
800	10,41	14,00
700	10,46	15,00
600	10,35	18,00
500	10,27	21,00
400	10,50	27,00
300	10,50	36,00
200	10,35	53,00
100	10,00	106,00
90	9,95	118,00
80	9,90	129,00
70	9,87	150,00
60	9,75	170,00
50	9,82	198,00
40	9,54	243,00
30	9,37	315,00
20	9,00	445,00
10	8,15	787,00
9	8,10	865,00
8	8,00	951,00
7	7,65	1.100,00
6	7,44	1.230,00
5	7,15	1.370,00
4	6,75	1.610,00
3	6,25	1.950,00
2	5,37	2.450,00

Table-60

- Using the voltage and current data you've recorded, draw a current-voltage (I-V) graph in the specified area. This graph will visually represent the relationship between the current and voltage at different resistance settings.

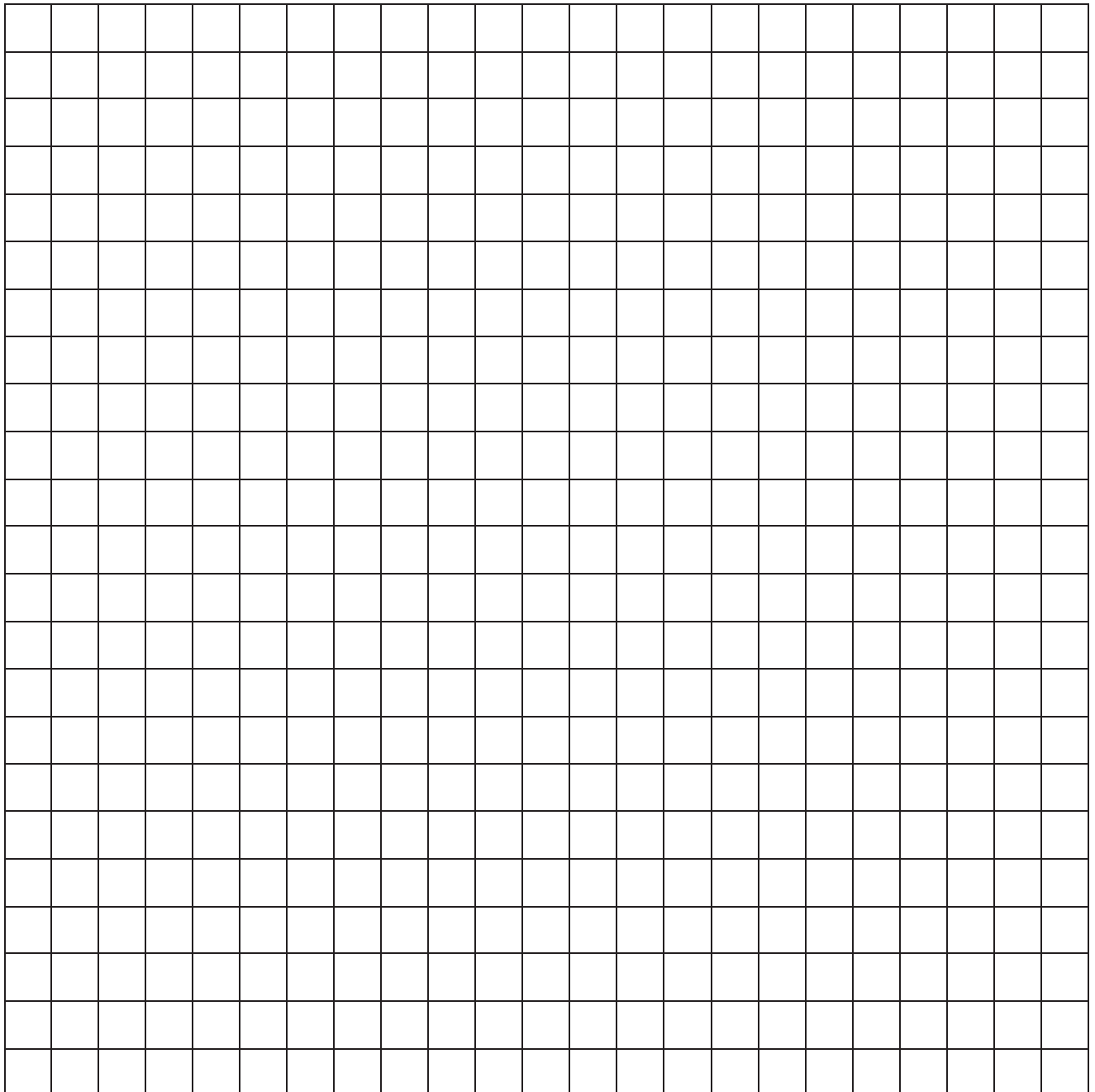

Graph-1

6. Compare the graph you have drawn with the reference graph provided. Analyze any similarities or differences in the patterns, slopes, and key points between your graph and the provided one. This comparison will help you understand the accuracy of your experimental results and any deviations from the expected behaviour.

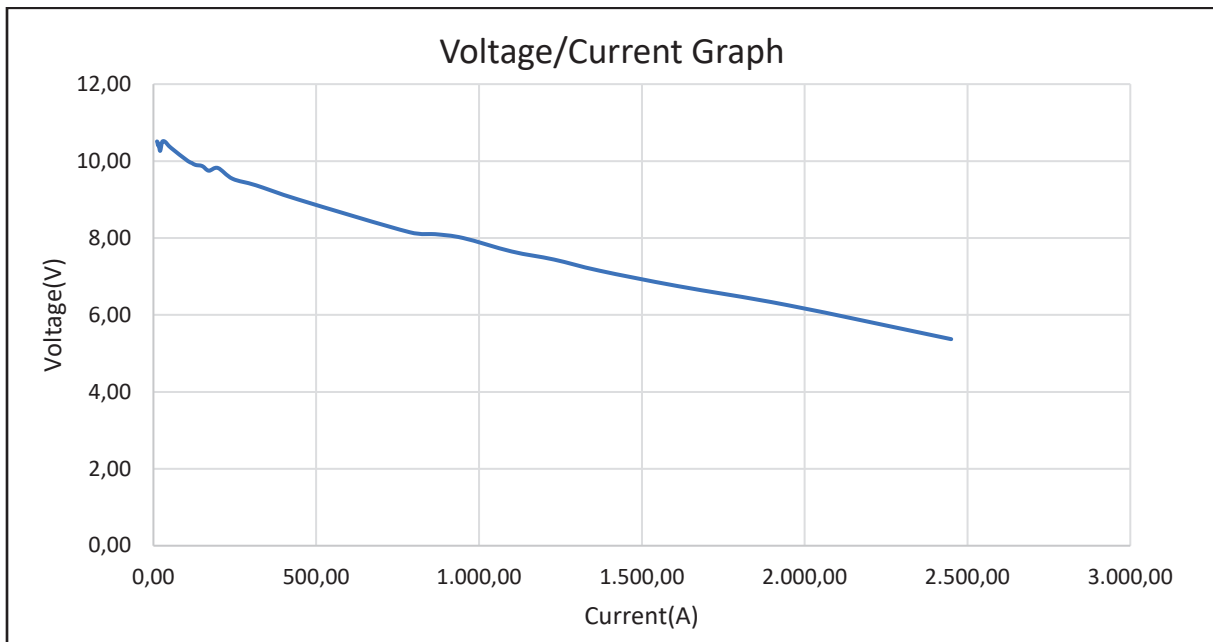

Graph XVIII

Thank You for Reading!
We hope you found this manual
informative and useful.